

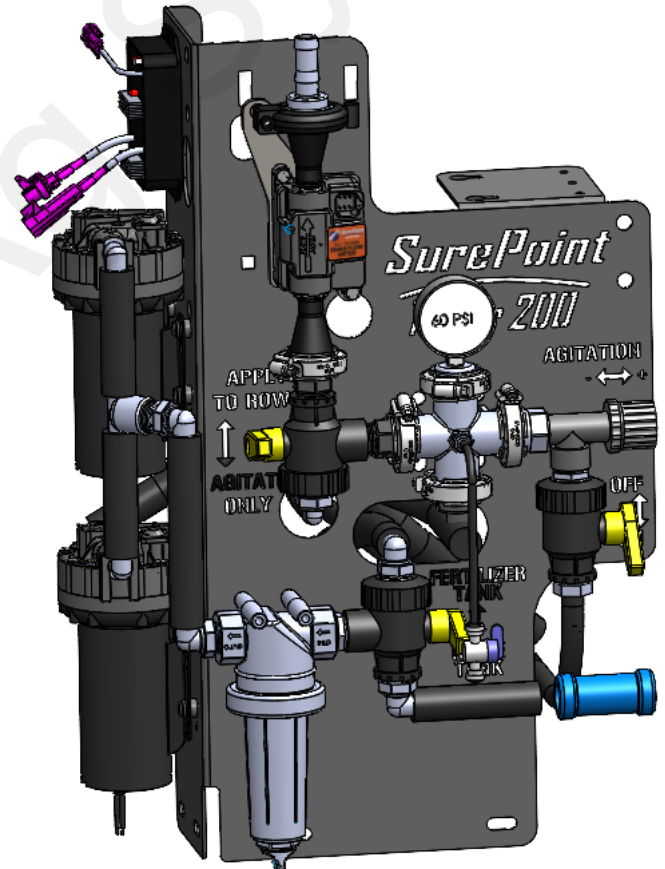

396-6661Y1

Tower 110 & 200, Orion 3 DN4 & DN10 Flowmeter Retrofit Kits Instructions

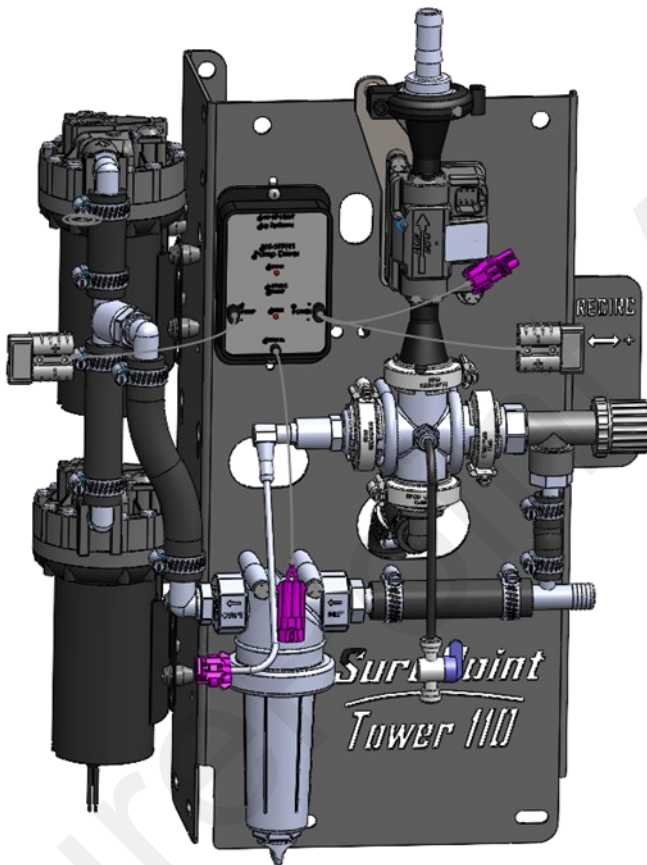
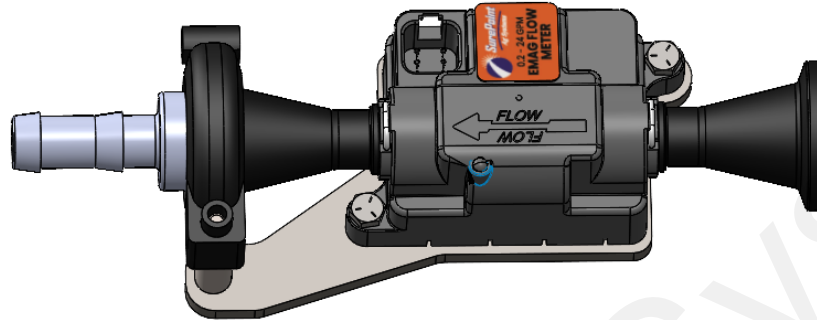

Kit Number:

511-01-DN10 : Retrofit Kit, Tower 110 Orion 3 DN10, 0.2 - 24 GPM

511-01-DN4 : Retrofit Kit, Tower 110 Orion 3 DN4, 0.08-1.6 GPM

511-02-DN10 : Retrofit Kit, Tower 200 Orion 3 DN10, 0.2 - 24 GPM



Parts List and Exploded View

511-01-DN10 — Retrofit Kit, Tower 110 Orion 3 DN10, 0.2 - 24 GPM

ITEM #	Part Number	Description	QTY
1	105-100075BRB	1" Manifold x 3/4" HB	1
2	105-100G-H	1" EPDM Manifold Gasket	2
3	105-FC100	1" Manifold Clamp	1
4	105-UFC100	1" UF Clamp	1
5	204-01-462032A-DN10	Flowmeter Assembly, Orion3 Emag, 0.2 - 24 GPM, M100 Flange	1
6	300-040108-SS	1/4" x 1-1/2" Hex Head Bolt - SS	2
7	300-M655MM-10.9	M6 x 55mm, Hex Flange Head Bolt - Grade 10.9	1
8	323-04-SS	1/4" Flange Nut -SS	2
9	400-6633Y1	Spacer Bushing, Steel 1/2"OD x 1/4" ID x 7/8" Long	1
10	410-6613Y1-BK	Spacer, Orion 3 Flowmeter With Tab for Tower	1

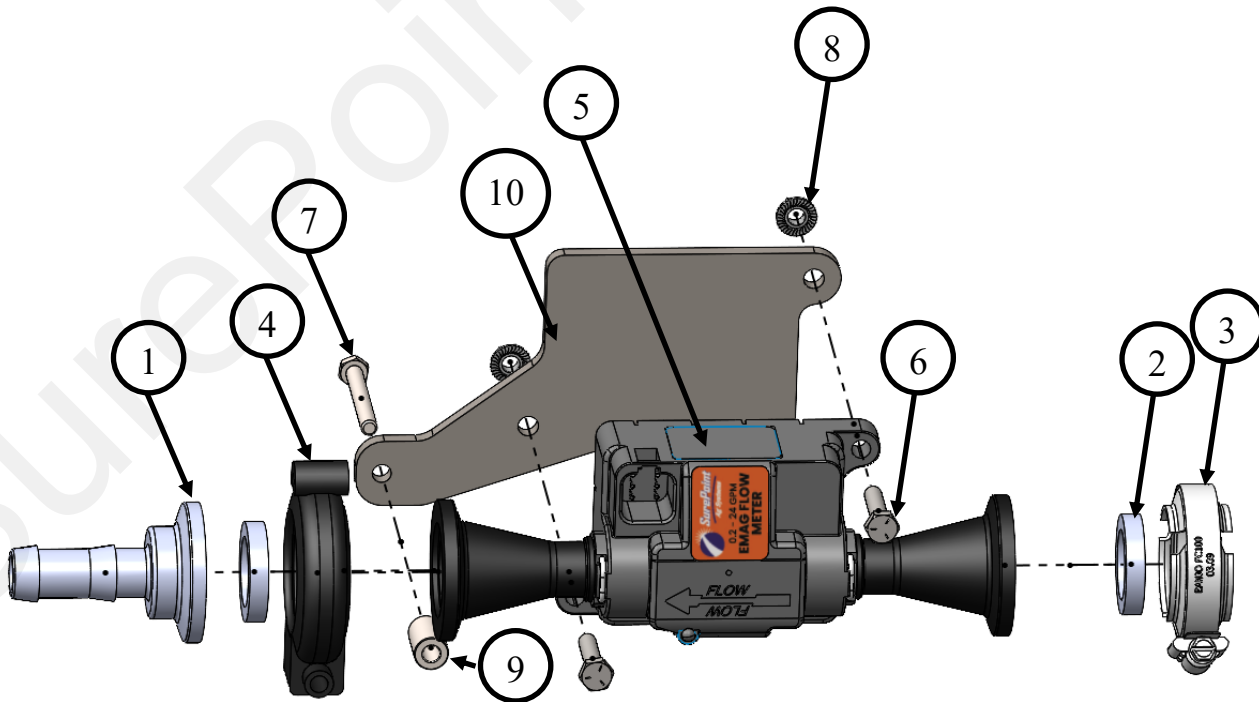



Parts List and Exploded View

511-01-DN4 — Retrofit Kit, Tower 110 Orion 3 DN4, 0.08-1.6 GPM

ITEM #	Part Number	Description	QTY
1	105-100075BRB	1" Manifold x 3/4" HB	1
2	105-100G-H	1" EPDM Manifold Gasket	2
3	105-FC100	1" Manifold Clamp	1
4	105-UFC100	1" UF Clamp	1
5	204-01-46203GA-DN04	Flowmeter Assembly, Orion3 Emag, 0.08 - 1.6 GPM, 1/2" MPT Connections	1
6	300-040108-SS	1/4" x 1-1/2" Hex Head Bolt - SS	2
7	300-M655MM-10.9	M6 x 55mm, Hex Flange Head Bolt - Grade 10.9	1
8	323-04-SS	1/4" Flange Nut -SS	2
9	400-6633Y1	Spacer Bushing, Steel 1/2"OD x 1/4" ID x 7/8" Long	1
10	410-6613Y1-BK	Spacer, Orion 3 Flowmeter With Tab for Tower	1
11	124-01-G11056-V	O-Ring, Viton, T1 Fork Fittings	2
12	120-M100T1M	M100 to T1 Flange for DN10 meter	2

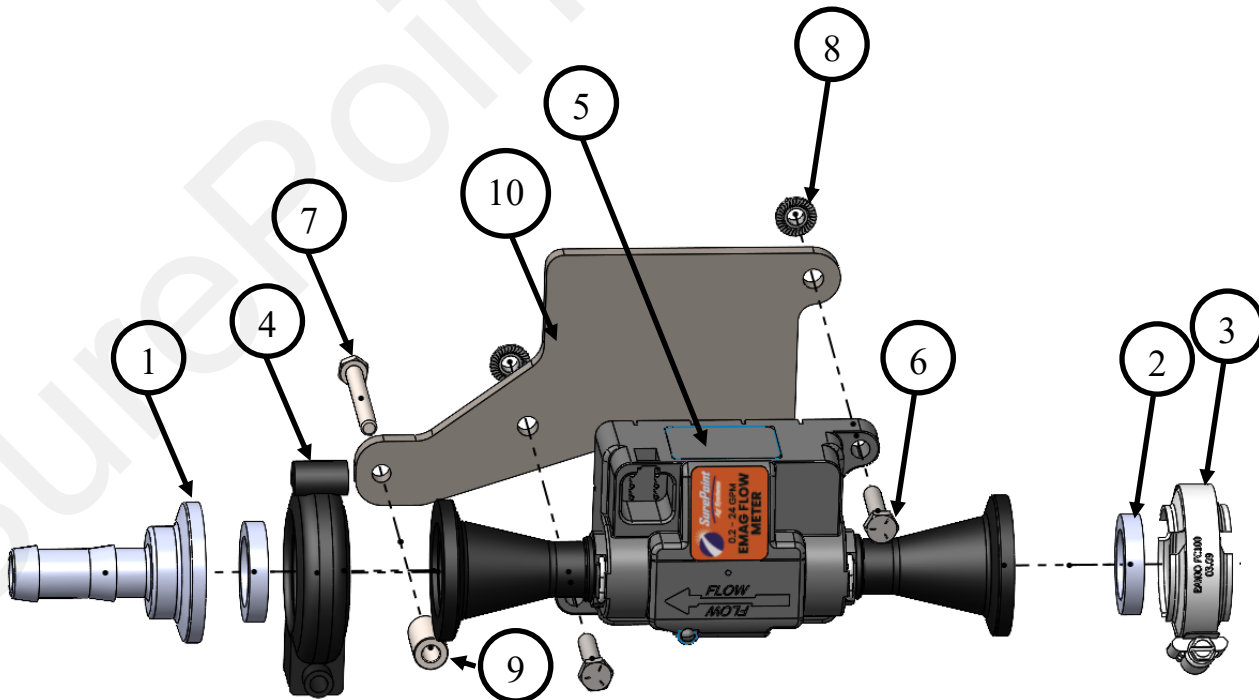



Parts List and Exploded View

511-02-DN10 — Retrofit Kit, Tower 200 Orion 3 DN10, 0.2 - 24 GPM

ITEM #	Part Number	Description	QTY
1	105-100075BRB	1" Manifold x 3/4" HB	1
2	105-100G-H	1" EPDM Manifold Gasket	2
3	105-FC100	1" Manifold Clamp	1
4	105-UFC100	1" UF Clamp	1
5	204-01-462032A-DN10	Flowmeter Assembly, Orion3 Emag, 0.2 - 24 GPM, M100 Flange	1
6	300-040108-SS	1/4" x 1-1/2" Hex Head Bolt - SS	2
7	300-M655MM-10.9	M6 x 55mm, Hex Flange Head Bolt - Grade 10.9	1
8	323-04-SS	1/4" Flange Nut -SS	2
9	400-6633Y1	Spacer Bushing, Steel 1/2"OD x 1/4" ID x 7/8" Long	1
10	410-6613Y1-BK	Spacer, Orion 3 Flowmeter With Tab for Tower	1
11	105-100075MPT	1" Manifold x 3/4" MPT	1

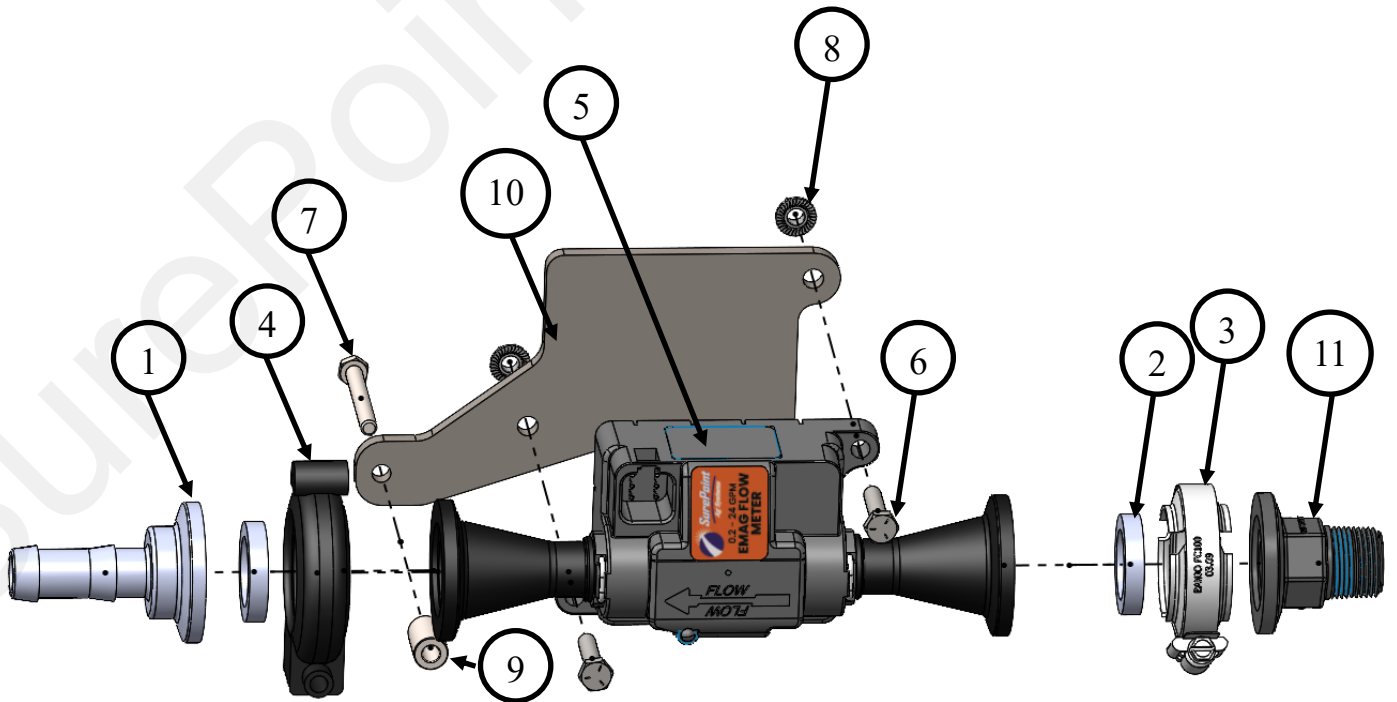



Parts List and Exploded View

204-01-462032A-DN10

Flowmeter Assembly, Orion3 Emag, 0.2 - 24 GPM, M100 Flange

ITEM #	Part Number	Description	QTY
1	204-01-462032	Flowmeter, Orion3 Emag, 0.2 - 24 GPM, T1F Connection	1
2	120-M100T1M	Flange Fitting, M100 x T1M Fork Fitting	2
3	124-02-010001	T1 Fork	2
4	124-01-G11056-V	Viton O-Ring for T1 Fittings	2
5	398-20-6313Y1	Decal, EMAG (Orion 3) Flowmeter 0.2—24 GPM	1

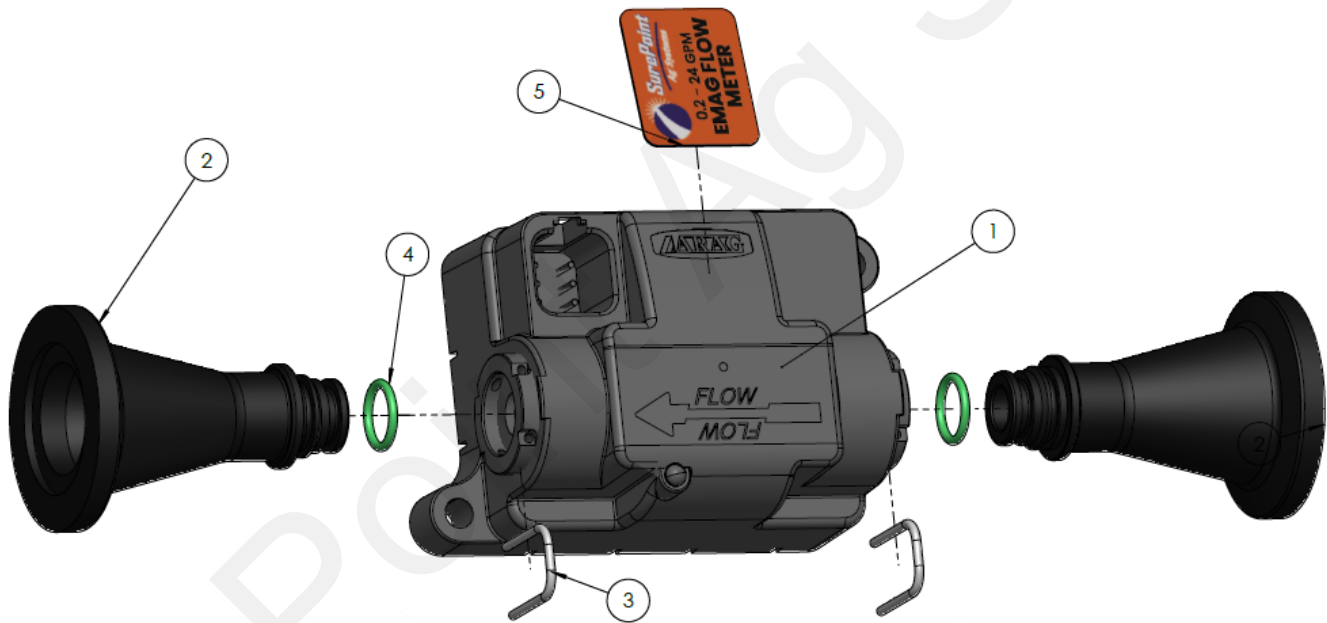



Parts List and Exploded View

204-01-46203GA-DN04

Flowmeter Assembly, Orion3 Emag, 0.08 - 1.6 GPM, 1/2" MPT Connections

ITEM #	Part Number	Description	QTY
1	204-01-46203G	FLOWMETER, ORION3 EMAG, 0.08-1.6GPM, T1F CONNECTION	1
2	398-20-6312Y1	DECAL, EMAG (ORION3) FLOWMETER 0.08-1.6 GPM	1
3	120-T1M050MPT	FORKFITTING, T1M x 1/2" MPT	2
4	124-02-010001	T1 Fork	2
5	124-01-G11056-V	Viton O-Ring for T1 fittings	2

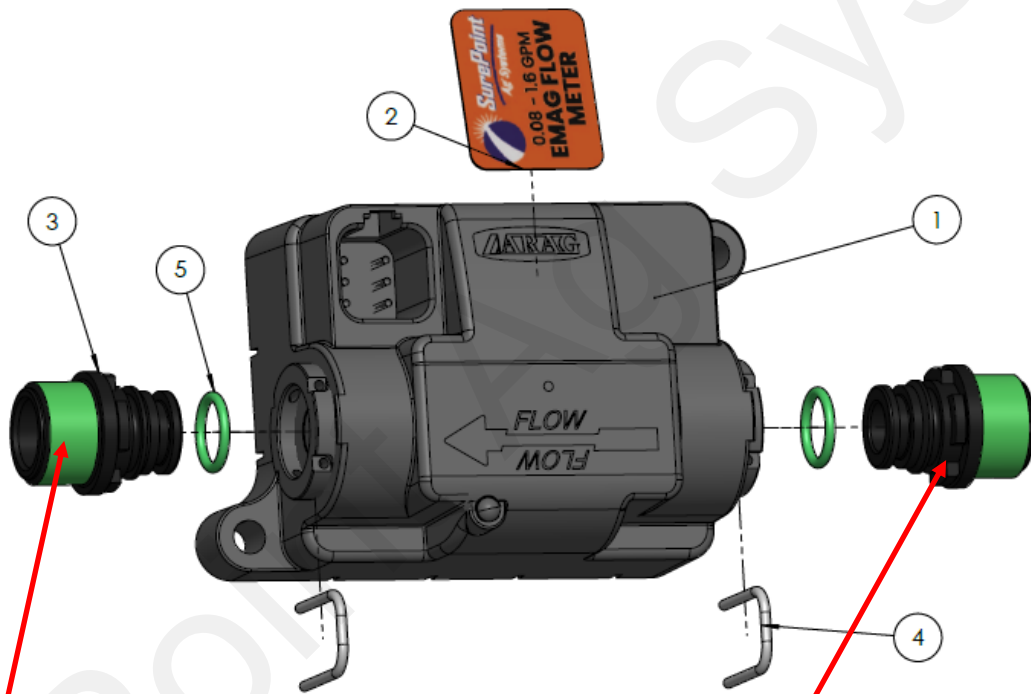

NOTE: For use in the Tower 110, Remove both 120-T1M050MPT from the flowmeter assembly and replace with two 120-M100T1M (supplied in kit 511-01-DN4)

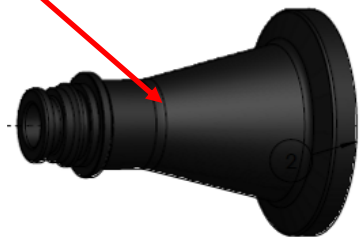

120-M100T1M

Step by Step Instructions Tower 110 Old Flowmeter Removal

1. Disconnect harness from flowmeter electrical connection point.
2. Detach hose from flowmeter outlet. Hose and hose-clamp will be reused if possible.
3. Loosen 1" manifold clamp on flowmeter inlet flange fitting.
4. Remove 2x hex bolts holding flowmeter bracket to Tower frame.
5. Remove and discard flowmeter/bracket assembly.

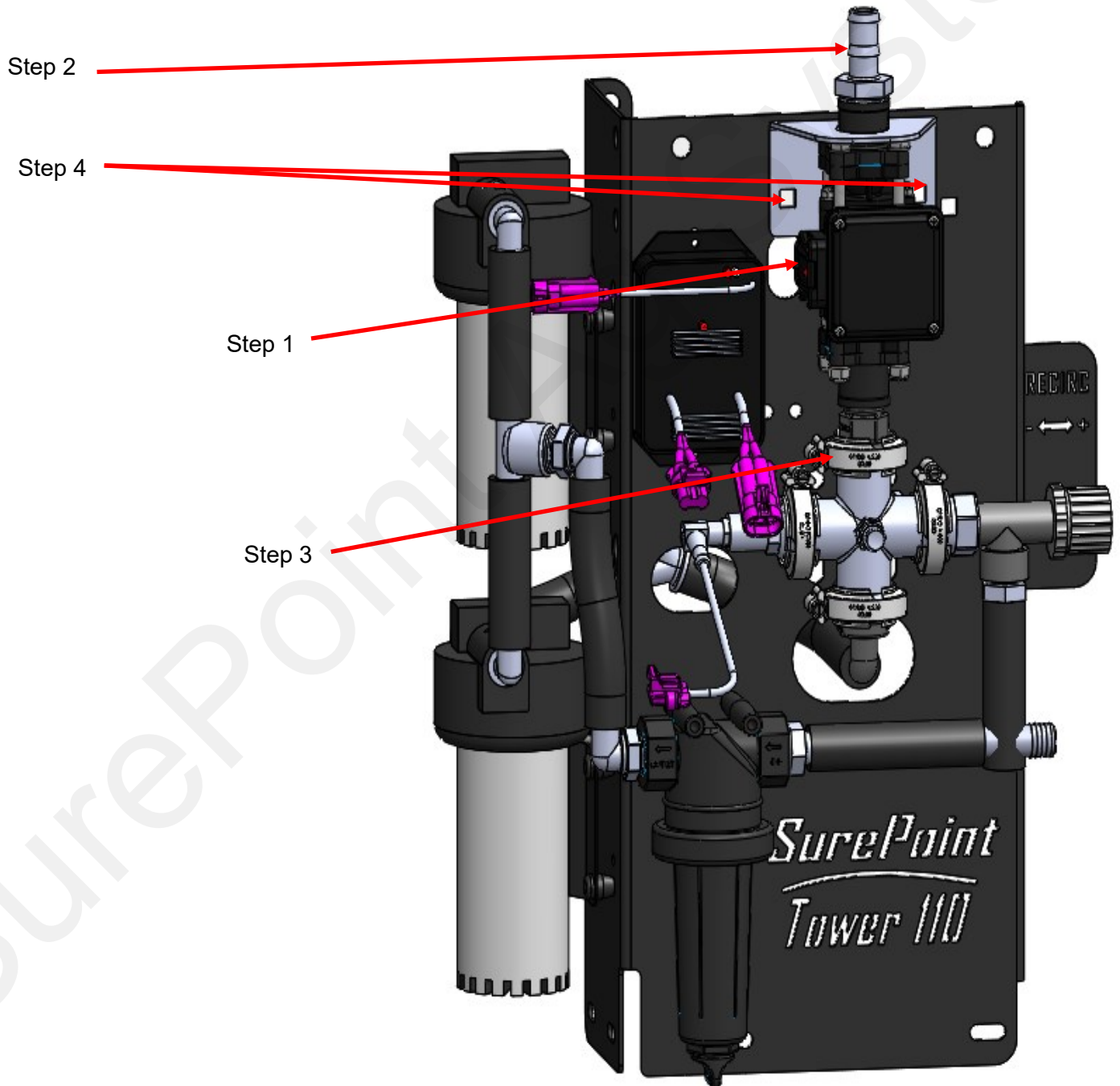



Tower 110 Step by Step Instructions

Drill holes for new flowmeter

1. Loosely assemble new flowmeter assembly to 1" manifold flange previous installed in Step 1. In this step use only on a clamp 105-FC100 [1" Manifold Clamp]. A gasket is not necessary in this step. NOTE: Ensure flowmeter Flow Arrow is pointing up
2. Rotate Flowmeter so its back plane is parallel to Tower frame. Flowmeter back plane will be about 1/4" from tower frame.
3. Using the two flowmeter 1/4" bolt holes as a guide insert a center punch into both bolt holes and mark tower frame metal with the center point of each hole.
4. Loosen manifold clamp and remove Flowmeter Assembly and set aside for safety while drilling.
5. Drill 2x 1/4" holes in location marked in Step 3.

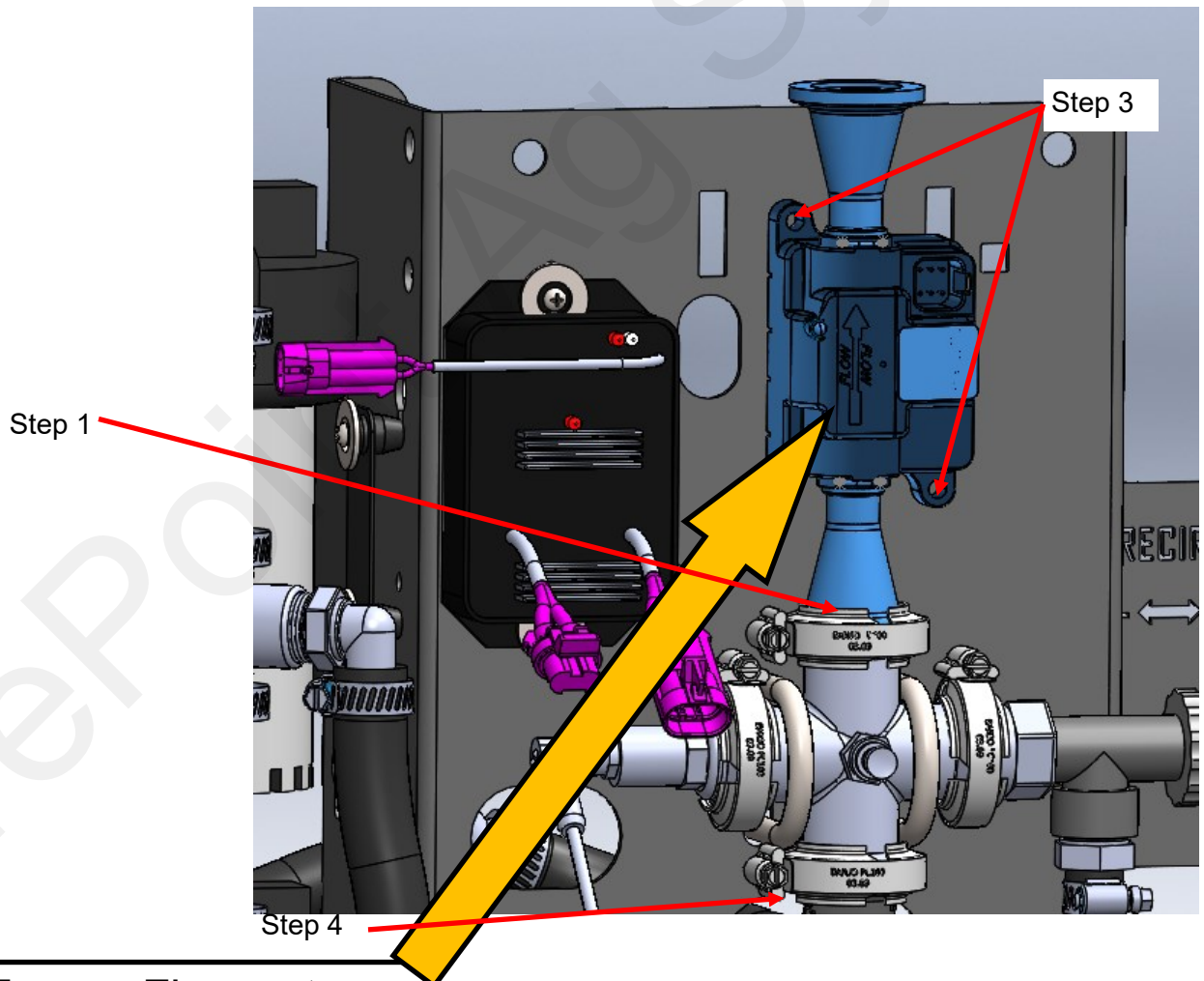

NOTE: Ensure Flowmeter Flow Arrow is Pointing UP.



Tower 110 Step by Step Instructions

Attach flowmeter to Tower Frame

1. Loosely assembly flowmeter 204-01-462032A-DN10 to 1" manifold fitting on top of 3-way valve. Use gasket 105-100G-H and clamp 105-FC100. NOTE: Ensure flow meter flow arrow is point UP.
2. Slide metal spacer 410-6613Y1-BK between flowmeter back plane and tower frame. Loosely hold in place by inserting two hex bolts 300-040108-SS [1/4" x 1-1/2" Hex Head Bolt - SS] in flowmeter, spacer and frame bolt holes.
3. Fully tighten flowmeter inlet manifold clamp
4. Use two Hex Nuts 323-04-SS [1/4" Flange Nut -SS], on Hex bolts from Step 2 to secure flowmeter, and spacer plate to tower frame.

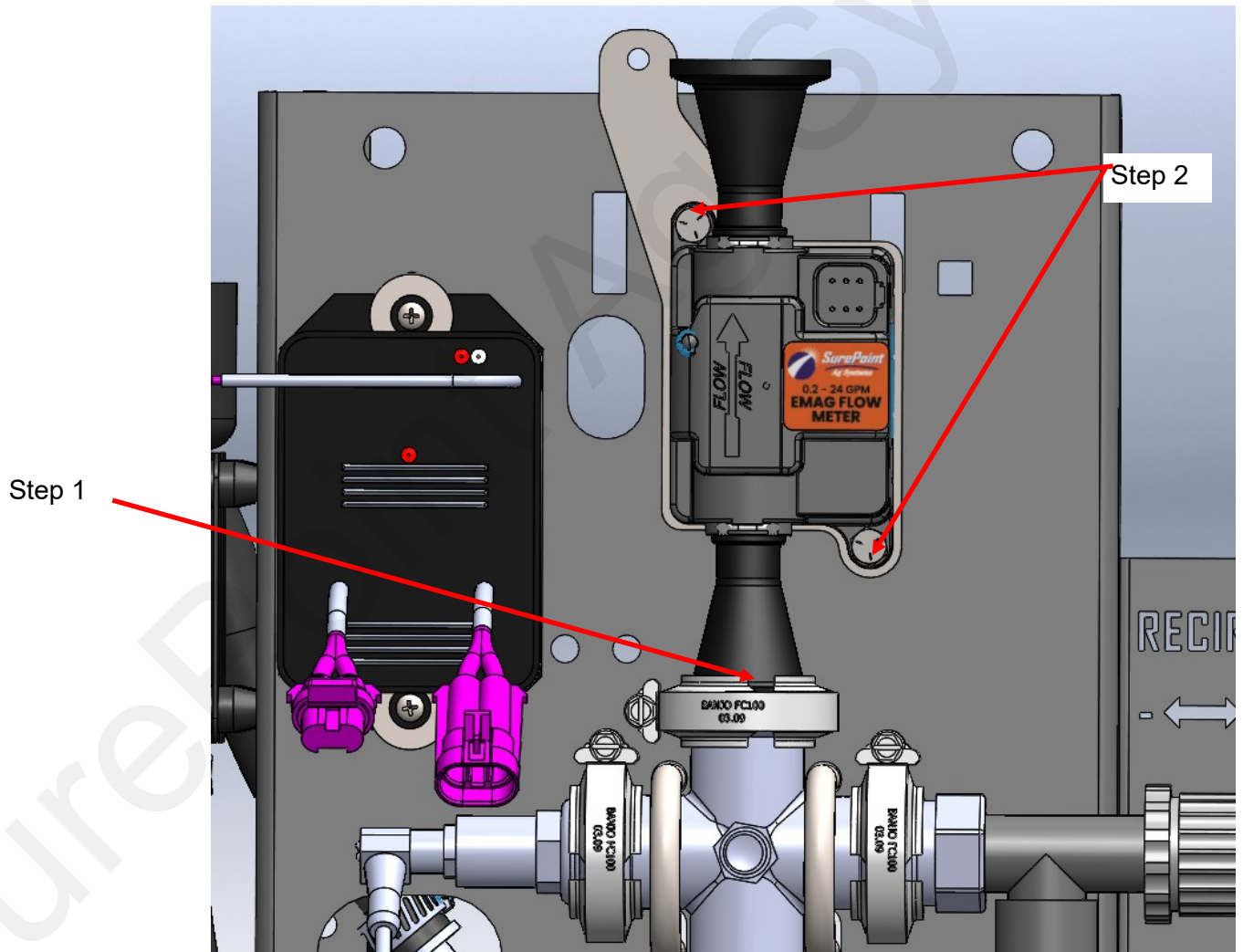

NOTE: Ensure Flowmeter Flow Arrow is Pointing UP.



Tower 110 Step by Step Instructions

Attach Hose barb to Flowmeter Outlet

1. Position 1" gasket [105-100G-H — 1" EPDM Manifold Gasket], and 3/4" hose barb fitting [105-100075BRB — 1" Manifold x 3/4" HB] on the flowmeters outlet flange (top), loosely secure with clam shell clamp [105-UFC100 — 1" UF Clamp] . Clamshell orientation is important; —captured nut in clamp should be on "left" side of pipe axis and capture nut half of the clamshell should be "away" from the bracket metal.
2. Using M6 x 55mm hex bolt [300-M655MM-SS — M6 x 55mm, Hex Flange Head Bolt - SS] and 7/8" Spacer Bushing [400-6633Y1 — Spacer Bushing, Steel 1/2"OD x 1/4" ID x 7/8" Long], secure clamshell clamp to bracket through top hole. This connection will also clamp and seal the 1" manifold connection to the hose barb fitting.
3. Reattach flowmeter outlet hose to flowmeter hose barb using hose clamp.
4. Using supplied harness adapter connect "flowmeter-labeled" harness lead to 6-pin connection point on new flowmeter.
5. Update flowmeter calibration number in controller settings (see last page).

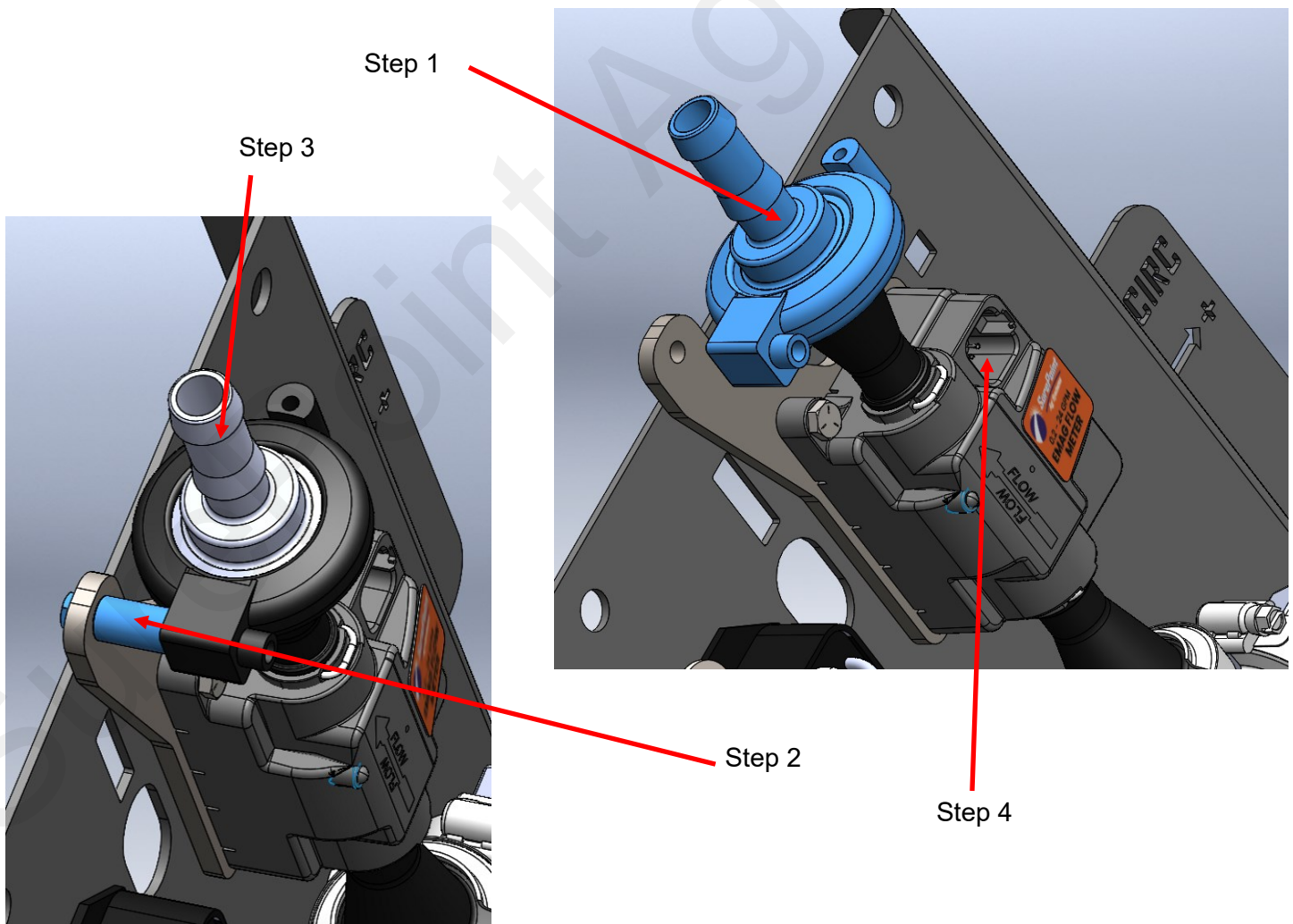

Step by Step Instructions Tower 200 Old Flowmeter Removal

1. Disconnect harness from flowmeter electrical connection point.
2. Detach hose from flowmeter outlet. Hose and hose-clamp will be reused if possible.
3. Loosen hose clamp on bottom of flowmeter inlet hose.
4. Remove 4x hex bolts holding flowmeter bracket to Tower frame.
5. Remove and discard flowmeter/bracket assembly.
6. Unscrew hose barb fitting from top of 3-Way valve and discard

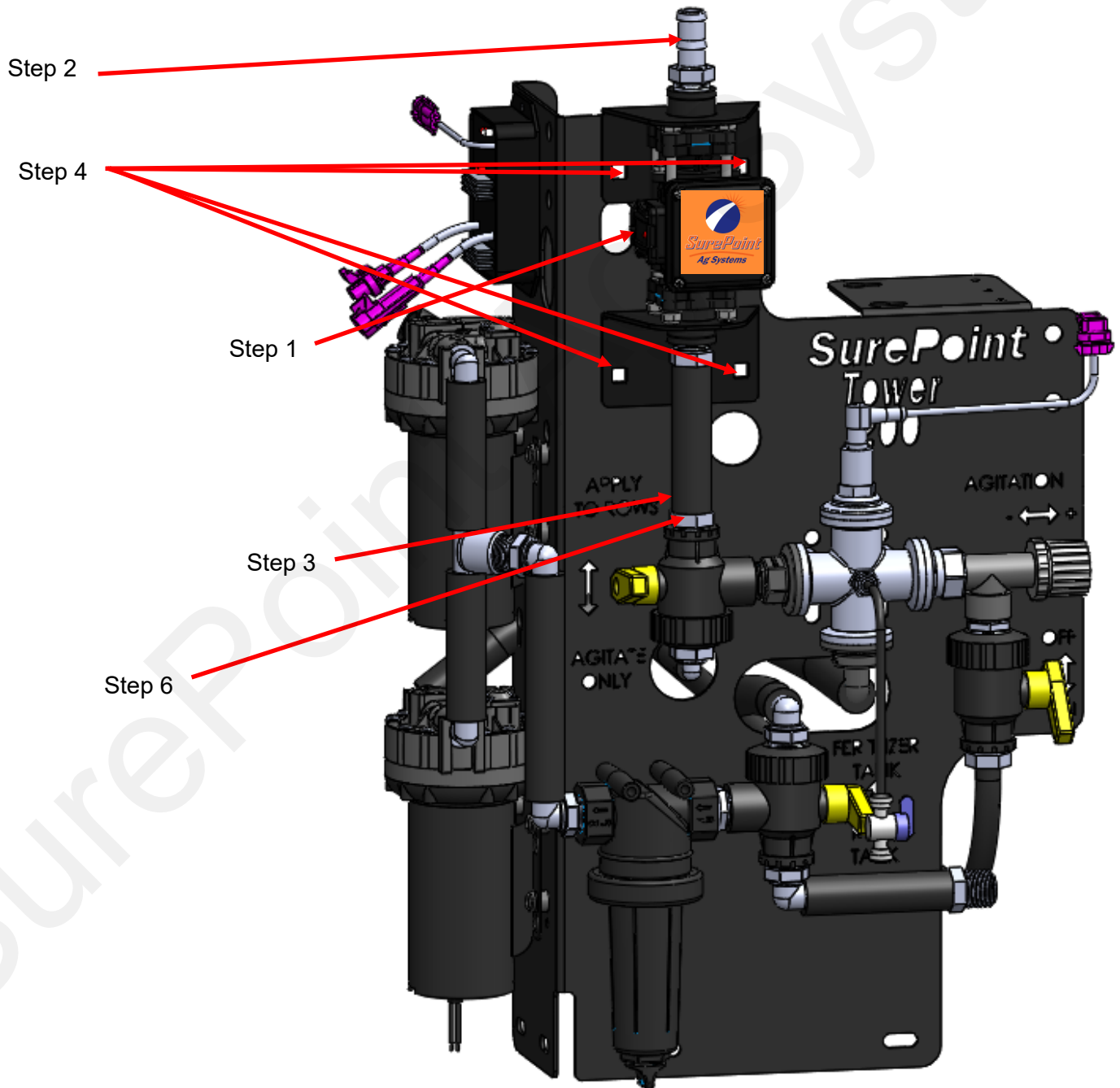



Tower 200 Step by Step Instructions

Drill holes for new flowmeter

1. Screw new fitting 105-100075MPT [1" Manifold x 3/4" MPT] into top of 3-way valve and tighten. (Thread tape and/or thread sealant is recommended)
2. Loosely assemble new flowmeter assembly to 1" manifold flange previous installed in Step 1. In this step use only on a clamp 105-FC100 [1" Manifold Clamp]. A gasket is not necessary in this step. NOTE: Ensure flowmeter Flow Arrow is pointing up
3. Rotate Flowmeter so its back plane is parallel to Tower frame. Flowmeter back plane will be about 1/4" from tower frame.
4. Using the two flowmeter 1/4" bolt holes as a guide, insert a center punch into both bolt holes and mark tower frame metal with the center point of each bolt hole.
5. Loosen manifold clamp and remove flowmeter assembly and set aside for safety while drilling.
6. Drill 2x 1/4" holes in locations marked in Step 4.

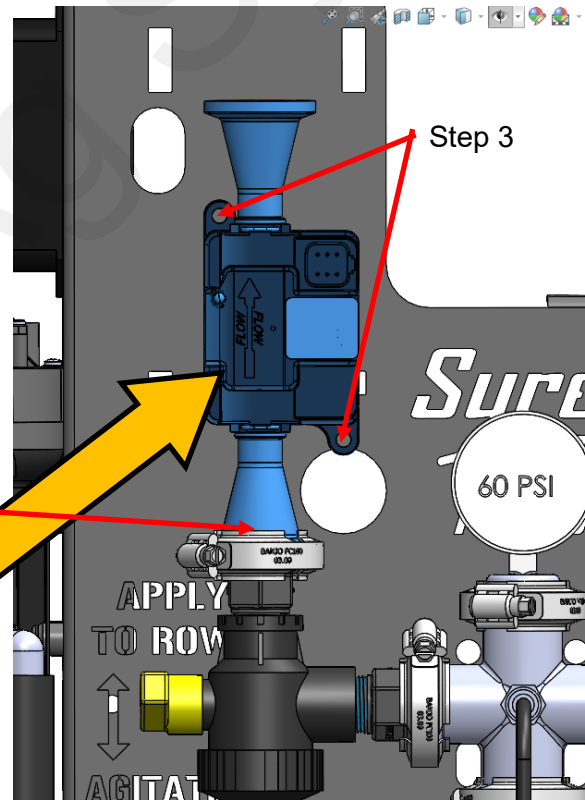
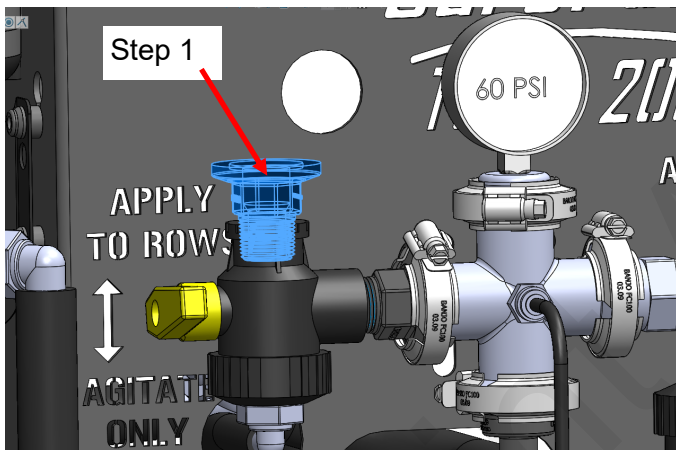

Step 2

NOTE: Ensure Flowmeter Flow Arrow is Pointing UP.



Tower 200 Step by Step Instructions Drill 3rd hole for new flowmeter

1. Using two new holes just drilled on previous page, attach metal spacer 410-6613Y1-BK [Spacer, Orion 3 Flowmeter With Tab for Tower]. Use 2x 1/4" hex bolts and nuts. Only finger tighten in this step.
2. Use supplied metal spacer 410-6613Y1-BK as a drilling guide and drill 1/4" hole in the Tower frame in the location of the top (3rd) hole in the spacer bracket
3. Remove 2x 1/4" hex bolts and nuts from step 1
4. Frame is now ready to attach new flowmeter

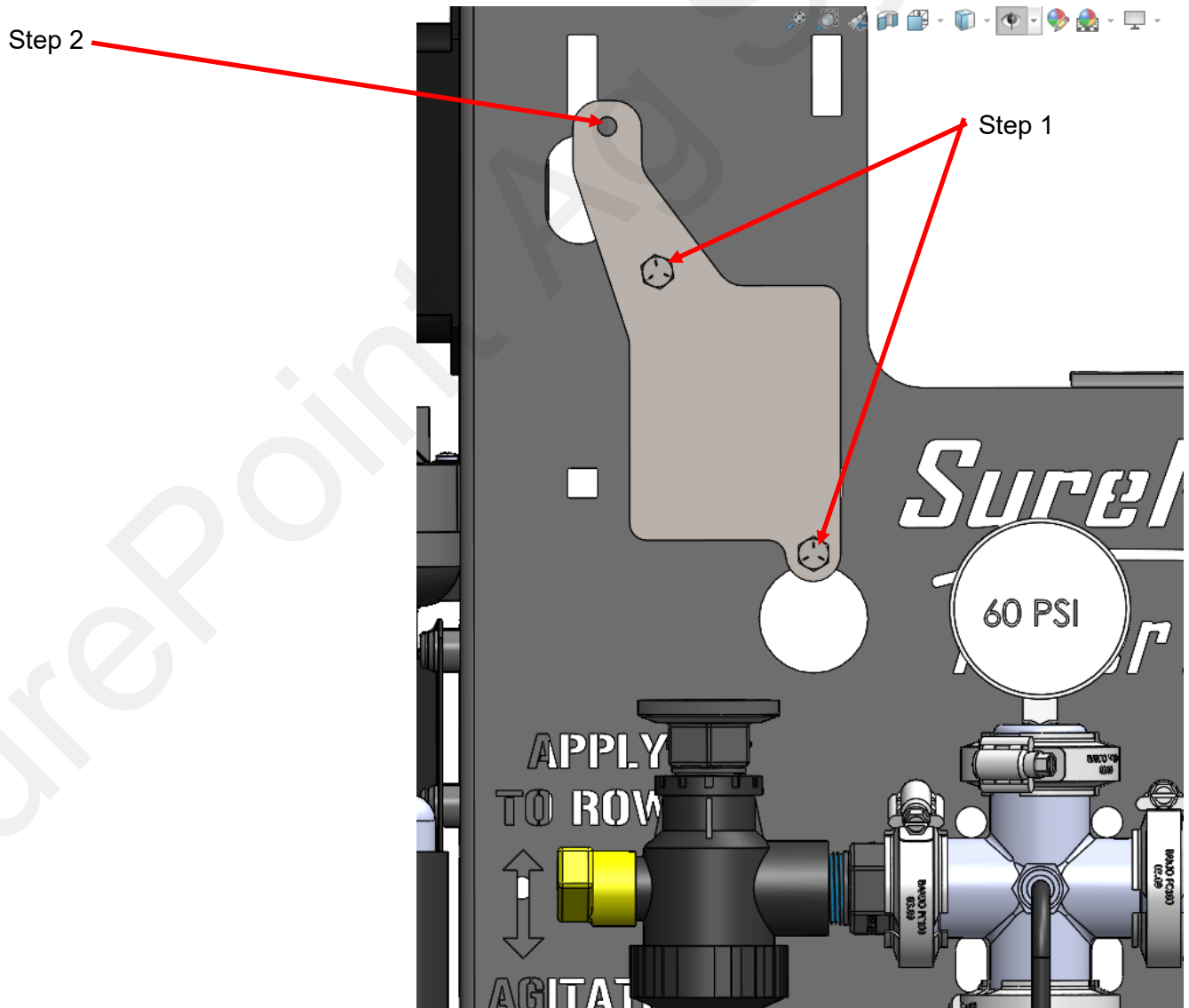



Tower 200 Step by Step Instructions

Attach flowmeter to Tower Frame

1. Loosely assembly flowmeter 204-01-462032A-DN10 to 1" manifold fitting on top of 3-way valve. Use gasket 105-100G-H and clamp 105-FC100. NOTE: Ensure flow meter flow arrow is point UP.
2. Slide metal spacer 410-6613Y1-BK between flowmeter back plane and tower frame. Loosely hold in place by inserting two hex bolts 300-040108-SS [1/4" x 1-1/2" Hex Head Bolt - SS] in flowmeter, spacer and frame bolt holes.
3. Fully tighten flowmeter inlet manifold clamp
4. Use two Hex Nuts 323-04-SS [1/4" Flange Nut -SS], on Hex bolts from Step 2 to secure flowmeter, and spacer plate to tower frame.

NOTE: Ensure Flowmeter Flow Arrow is Pointing UP.

Step 1

Step 2

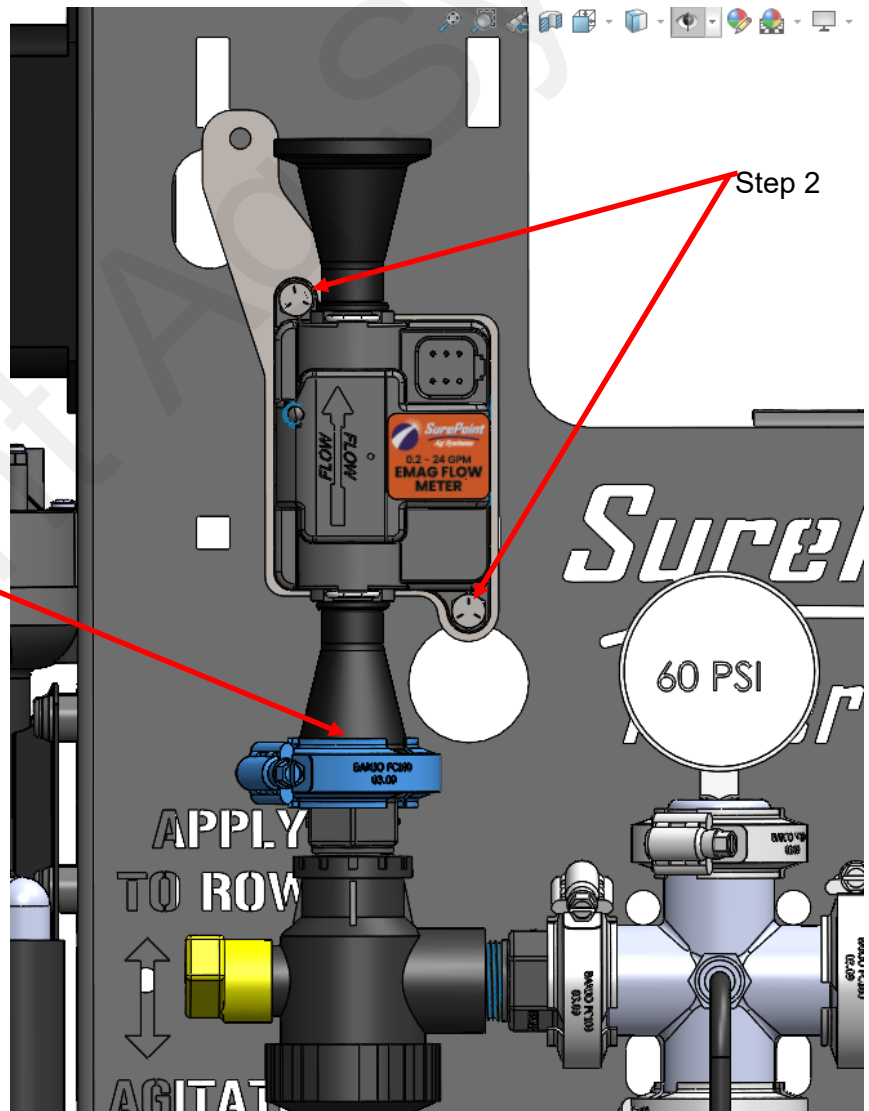



Tower 200 Step by Step Instructions

Attach Hose barb to Flowmeter Outlet

1. Position 1" gasket [105-100G-H — 1" EPDM Manifold Gasket], and 3/4" hose barb fitting [105-100075BRB — 1" Manifold x 3/4" HB] on the flowmeters outlet flange (top), loosely secure with clam shell clamp [105-UFC100 — 1" UF Clamp] . Clamshell orientation is important; —captured nut in clamp should be on "left" side of pipe axis and capture nut half of the clamshell should be "away" from the bracket metal.
2. Using M6 x 55mm hex bolt [300-M655MM-SS — M6 x 55mm, Hex Flange Head Bolt - SS] and 7/8" Spacer Bushing [400-6633Y1 — Spacer Bushing, Steel 1/2"OD x 1/4" ID x 7/8" Long], secure clamshell clamp to bracket and tower frame through top hole. This connection will also clamp and seal the 1" manifold connection to the hose barb fitting.
3. Reattach flowmeter outlet hose to flowmeter hose barb using hose clamp.
4. Using supplied harness adapter connect "flowmeter-labeled" harness lead to 6-pin connection point on new flowmeter.
5. Update flowmeter calibration number in controller settings (see last page).

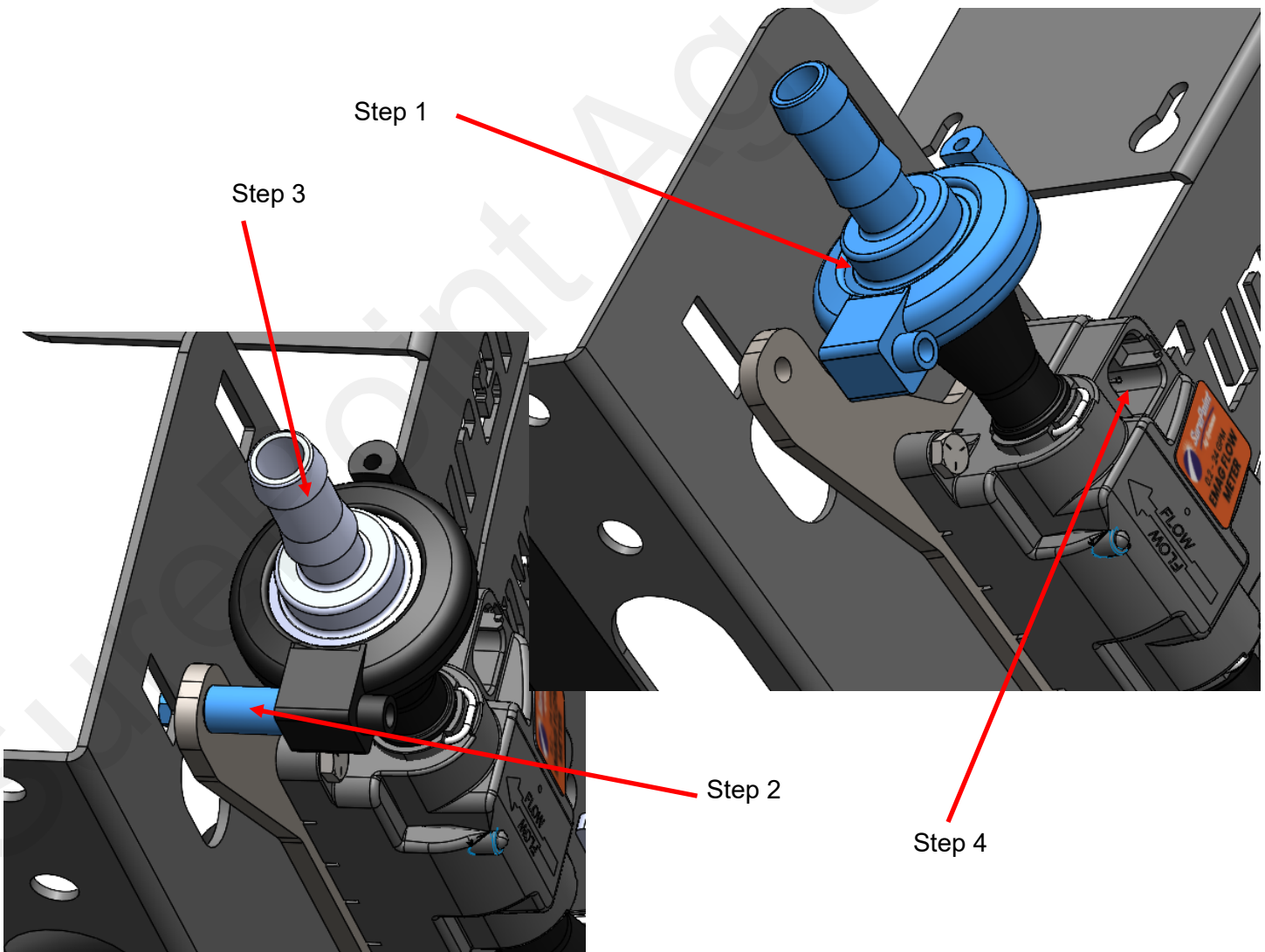

Tower 110 & 200 Electromagnetic Flowmeter Kits

Flowmeter only

0.2 - 24 GPM	Item Number 500-02-2310 (Tower 110 & 200)	204-01-462032A-DN10
0.08 - 1.6 GPM	Item Number 500-02-2310 (Tower 110)	204-01-46203GA-DN4

Kits include flowmeter, adapter harness, hose barb fittings & hose clamps.

-Before doing any arc welding on the implement, unplug the cable to the flowmeter, or damage to the flowmeter may result.

***-Do not power wash the flowmeter.** High pressure spray directed at the back edge of the face plate or at the wire connector may allow water into the flowmeter electronics.*

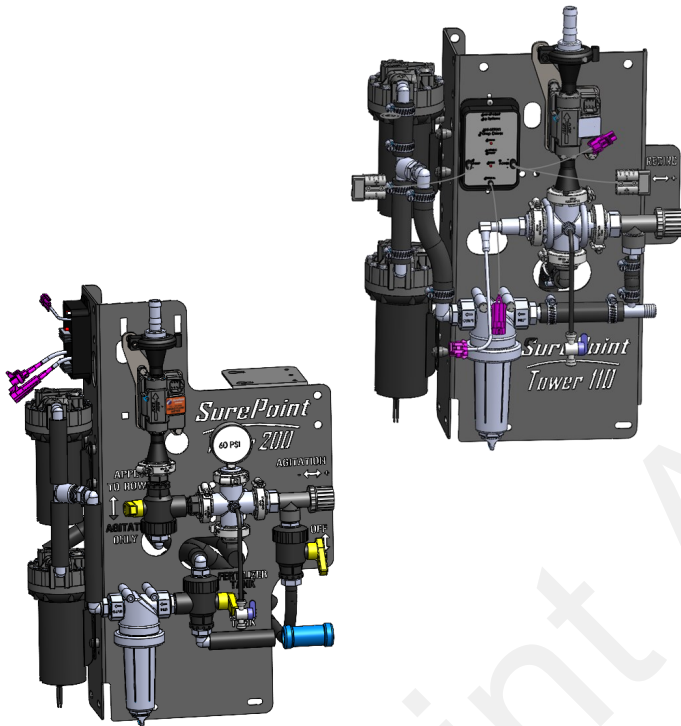

6-Pin Deutsch connector

Use adapter 201-5954Y1 to connect to 3-pin AMP Superseal harness. (Sentinel, John Deere, Ag Leader, Trimble setups)
 OR Alternate adapter 201-6647Y1 to connect to 3-pin MP Shroud (Commander II setups)

For 0.08-1.6 (DN4) flowmeter you may also need one of these two divide-by-8 cables for controllers that CANNOT handle a 5-digit calibration number.:

- 201-14266 (for Commander II setups)
- 201-19849 (for non-Commander II setups)

Electromagnetic flowmeters are superior to traditional turbine flowmeters in two basic ways. First, they have no moving parts. This translates into no wear items or potential for contaminants to jam a spinning turbine.

Second, electromagnetic flowmeters detect the flow by electrically measuring the velocity of the liquid, which makes them less sensitive to viscosity or density of the fluid measured. They are generally extremely accurate using the standard calibration number, but the user must verify this.

SurePoint recommends you perform a catch test to verify the system is properly installed and configured. Adjust the flow cal as needed based on accurate catch tests with the actual product or observation of gallons applied and acres worked.

Flowmeter Model	Pulses per gallon	Alternate Calibration Number- Pulses per Gallon	FPT Size	Hose Barb In kit
0.08 - 1.6 GPM (DN4)	37854	9464 w/ divide-by-8	3/4"	3/4"
0.2 - 24 GPM (DN10)	4542	N/A	3/4"	1"
Commander II & Other Rate Controllers w/ Cal Number Limitations				
Sentinel, John Deere, Ag Leader & Trimble Rate Controller Setups				

The flowmeters will accurately read higher than the rated range.

Earlier model flowmeters (gray meters with white labels with black text) have different calibration numbers. The flow cal number (pulses per gallon) is printed on the serial number sticker on the side of the flowmeter.