

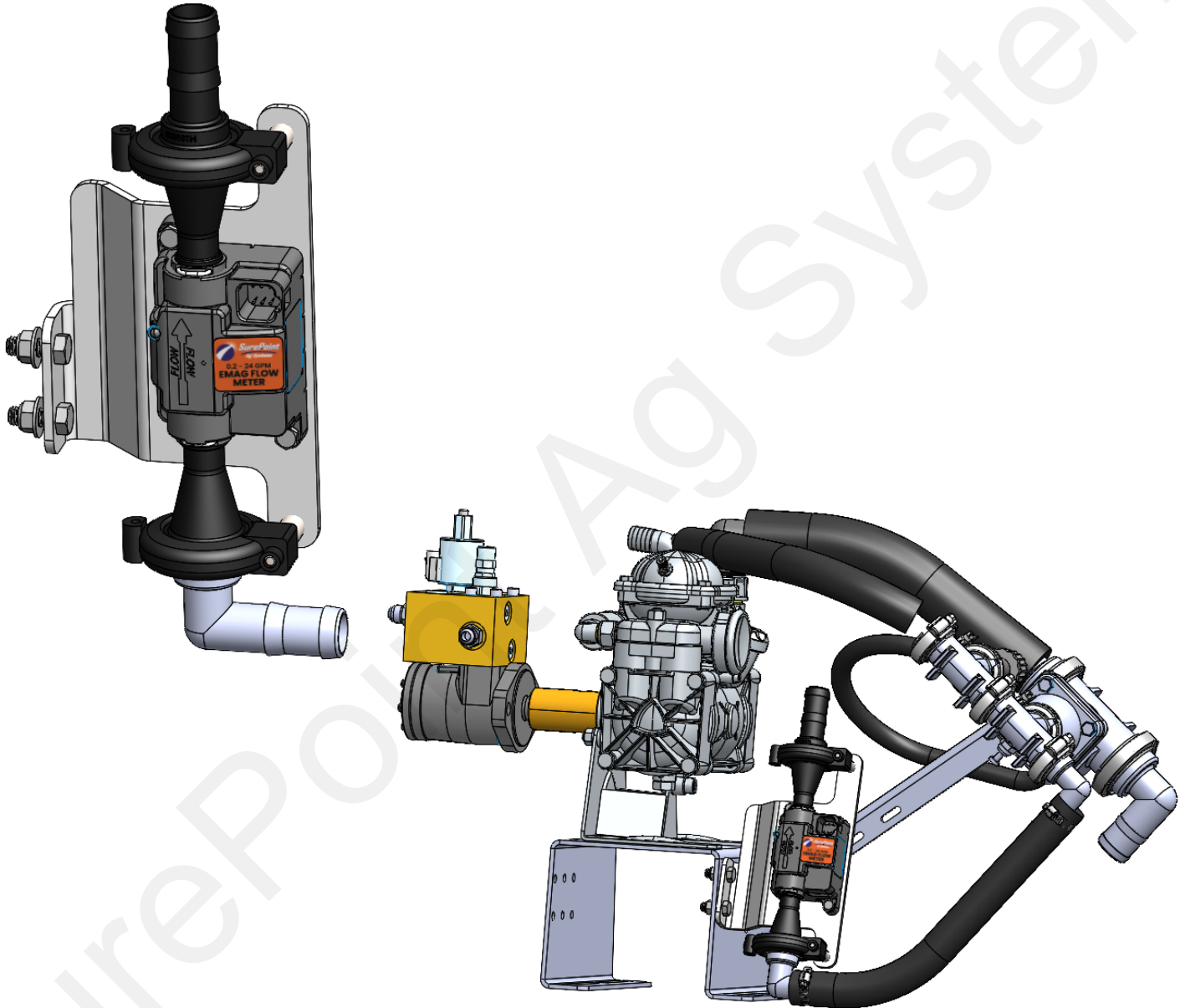

396-6657Y1

D70 Pump, Orion 3 DN10 Flowmeter Retrofit Kit Instructions



Kit Number:

500-02-2402 : DN10 Orion 3 Flowmeter Retrofit Kit for D70 Pump



Parts List and Exploded View

ITEM #	Part Number	Description	QTY
1	204-01-462032A-DN10	FLOWMETER ASSEMBLY, ORION3 EMAG, 0.2 - 24 GPM, M100 FLANGE	1
2	410-6643Y1-BK	Retrofit Bracket, Orion 3 to D70 Pump	1
3	105-100BRBWP90	1" Manifold X 1" HB, 90 degree sweep	1
4	105-UFC100	1" UF Clamp	2
5	400-6633Y1	Spacer Bushing, Steel 1/2"OD x 1/4" ID x 7/8" Long	2
6	300-M655MM-SS	M6 x 55mm, Hex Head Bolt - SS	2
7	300-040108-SS	BOLT, HEX HEAD, 1/4-20 x 1-1/2, STAINLESS STEEL	2
8	323-04-SS	NUT, SERRATED FLANGE, 1/4-20, STAINLESS STEEL	2
9	105-100BRB	1" Manifold x 1" HB	1
10	300-060100-SS	BOLT, HEX HEAD, 3/8-16 x 1, STAINLESS STEEL	2
11	323-06-SS	NUT, SERRATED FLANGE, 3/8-16, STAINLESS STEEL	2
12	105-100G-H	1" EPDM Manifold Gasket	2
13	350-1608	SS Hose Clamp - Size 16 - 1-1/2" Diameter (fits 1" AG200)	2
14	124-01-G11056-V	O-Ring, Viton, T1 Fork Fittings	2
15	124-02-010001	T1 fork	2
16	280-100-AG200	1" AG200 Bulk	20 in

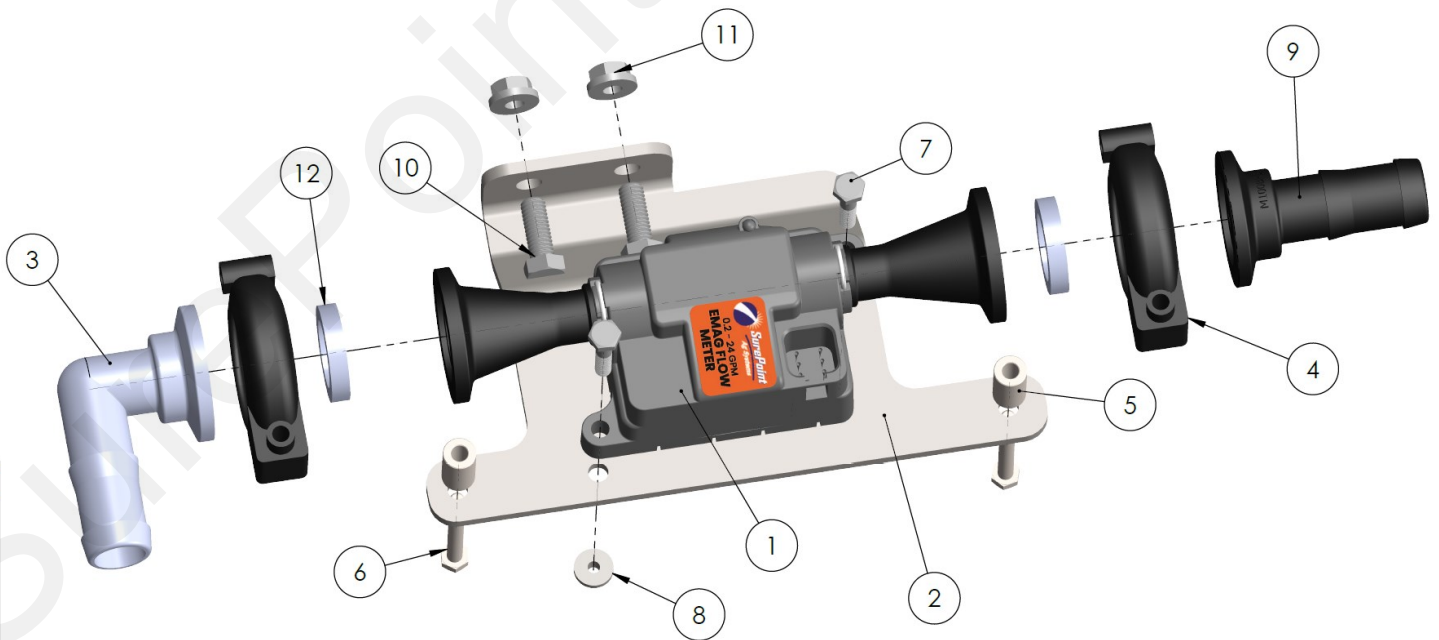



Parts List and Exploded View

ITEM #	Part Number	Description	QTY
1	204-01-462032	Flowmeter, Orion3 Emag, 0.2 - 24 GPM, T1F Connection	1
2	120-M100T1M	Flange Fitting, M100 x T1M Fork Fitting	2
3	124-02-010001	T1 Fork	2
4	124-01-G11056-V	Viton O-Ring for T1 Fittings	2
5	398-20-6313Y1	Decal, EMAG (Orion 3) Flowmeter 0.2—24 GPM	1

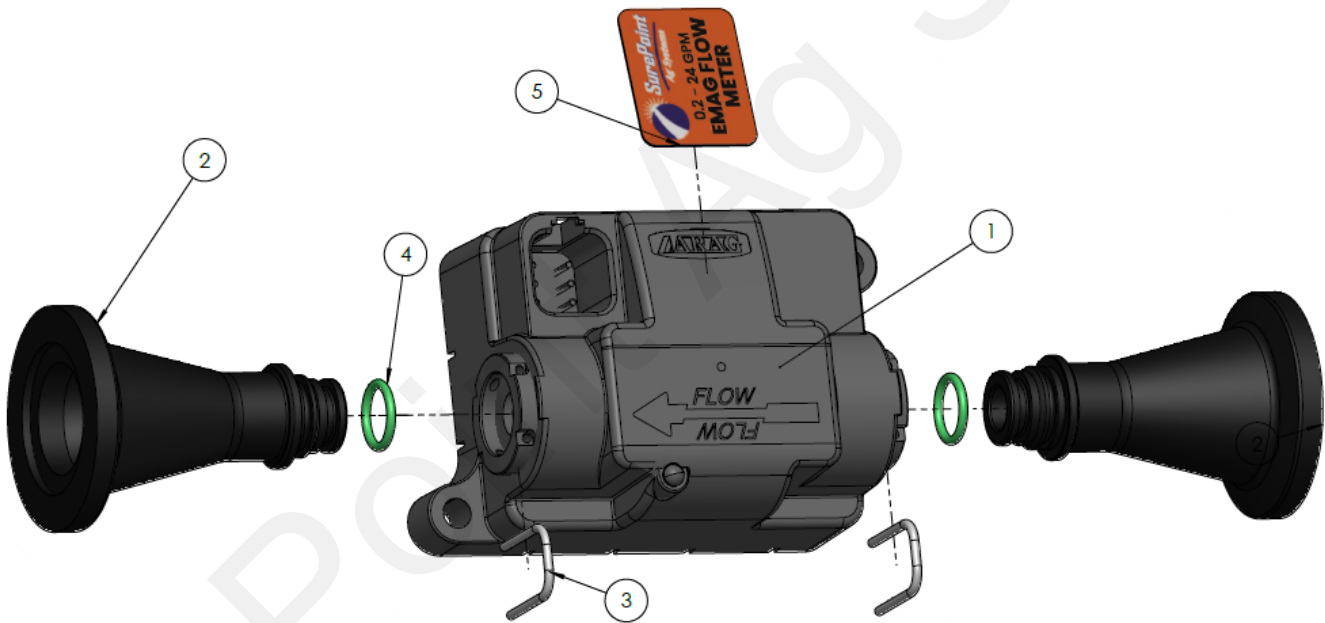

Step by Step Instructions Old Flowmeter Removal

1. Disconnect harness from flowmeter electrical connection point.
2. Detach hose from flowmeter outlet. Hose and hose-clamp will be reused if possible.
3. Detach hose from flowmeter inlet elbow. Hose will remain connected to pump.
4. Remove 2x 3/8" hex bolts holding flowmeter bracket to pump base.
5. Remove and discard flowmeter/bracket assembly.

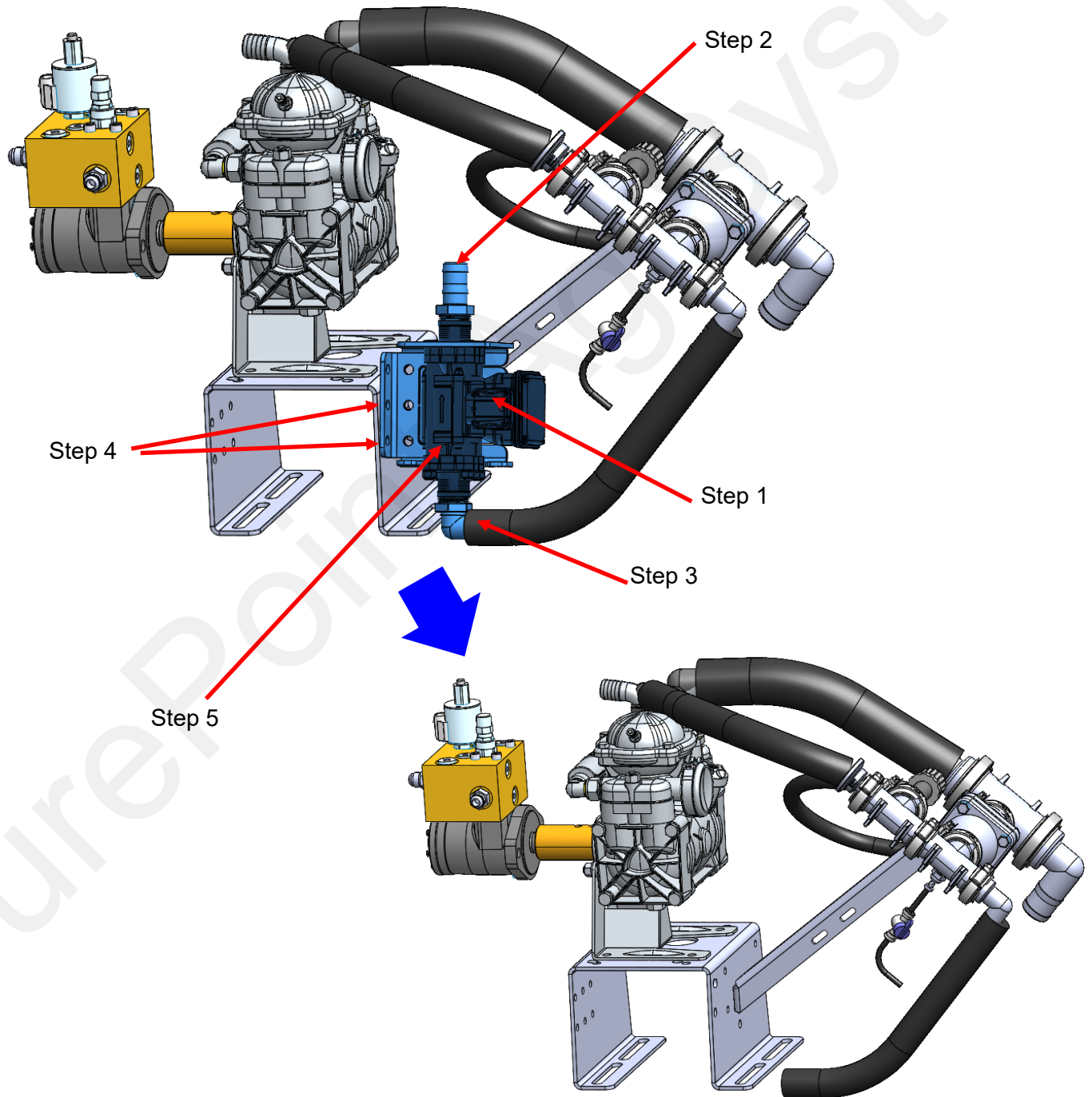



Step by Step Instructions Pre-Assembly– Flowmeter/Bracket

1. Attach new flowmeter assembly [204-01-462032A-DN10] to new bracket [410-6643Y1-BK], using two bolts [300-040108-SS — 1/4" x 1-1/2" Hex Head Bolt - SS] and nuts [323-04-SS — 1/4" Flange Nut - SS].
Ensure Flowmeter flow direction arrow is pointing up.
2. Remove the M6 bolt that comes in the 1" clamshell manifold clamps [105-UFC100 — 1" UF Clamp] and discard bolts.
3. Position 1" gasket [105-100G-H — 1" EPDM Manifold Gasket], and 1" hose barb fittings [105-100BRB — 1" Manifold x 1" HB] & [105-100BRB90 — 1" Manifold X 1" Barb, 90 degree elbow] on the flowmeters inlet and outlet flanges, loosely secure with clam shell clamp [105-UFC100 — 1" UF Clamp] . Clamshell orientation is important; —captured nut in clamps should be on "right" side of pipe axis and captured nut half of the clamshells should be "away" from the bracket metal.
4. Using M6 x 55mm hex bolt [300-M655MM-SS — M6 x 55mm, Hex Flange Head Bolt - SS] and 7/8" Spacer Bushing [400-6633Y1 — Spacer Bushing, Steel 1/2"OD x 1/4" ID x 7/8" Long], secure clamshell clamps to bracket through top and bottom hole. This connection will also clamp and seal the 1" manifold connection to the hose barb fittings.
5. Full flowmeter and bracket assembly is ready to assemble on to existing pump.

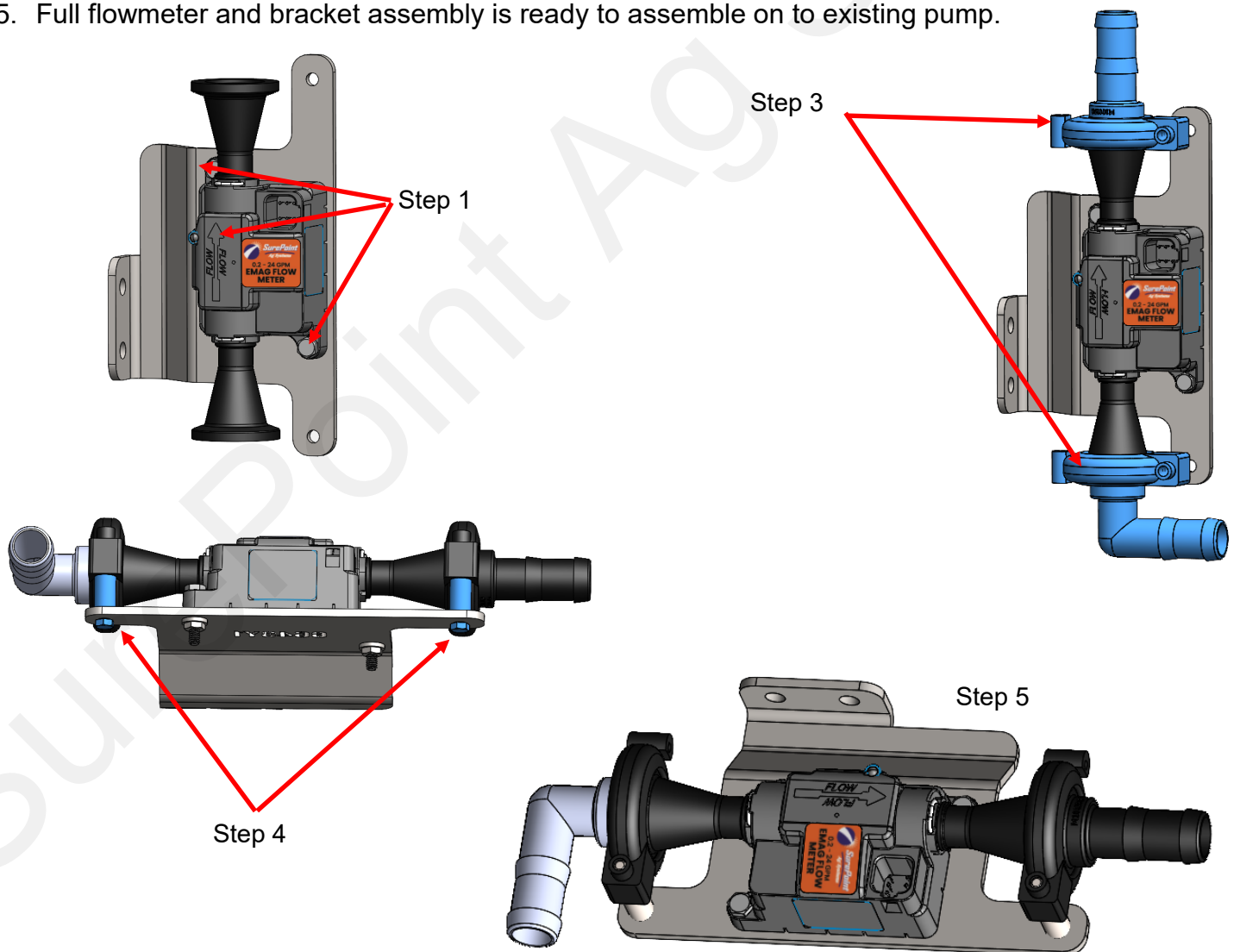

Step by Step Instructions Assembly– Flowmeter/Bracket to Pump

1. Attach the new flowmeter/bracket pre-assembly to pump base, using 4 bolts [300-060100-SS — BOLT, HEX HEAD, 3/8-16 x 1, STAINLESS STEEL] and nuts [323-06-SS — NUT, SERRATED FLANGE, 3/8-16, STAINLESS STEEL]. New flowmeter bracket will attach to pump base using same 2 holes in pump base that the old bracket was attached to. Flowmeter must be installed at a slant so that outlet hose can shoot the gap between the pump hoses.
2. Reattach 1” hose to hose barb elbow on inlet flange of new flowmeter, using hose clamp. Existing hose may require some shortening.
3. Reattach flowmeter outlet hose to flowmeter hose barb using hose clamp.
4. Using supplied harness adapter connect “flowmeter-labeled” harness lead to 6-pin connection point on new flowmeter.
5. Update flowmeter calibration number in controller settings (see next page).

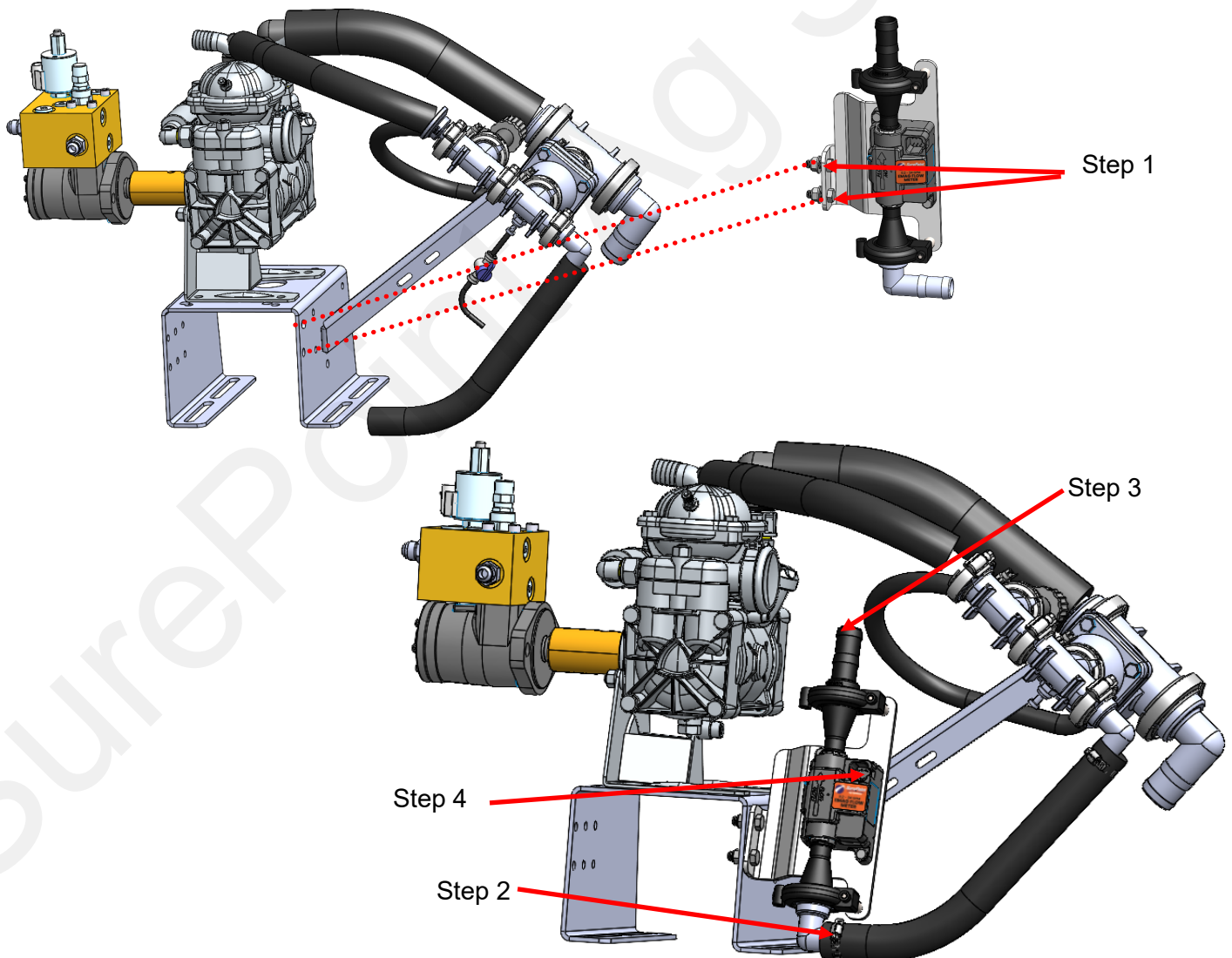

D70 Electromagnetic Flowmeter Kit

Flowmeter only

0.2 - 24 GPM

Item Number 500-02-2310 (PR17 & PR30)

204-01-462032A-DN10

Kits include flowmeter, adapter harness, hose barb fittings & hose clamps.

-Before doing any arc welding on the implement, unplug the cable to the flowmeter, or damage to the flowmeter may result.

***-Do not power wash the flowmeter.** High pressure spray directed at the back edge of the face plate or at the wire connector may allow water into the flowmeter electronics.*

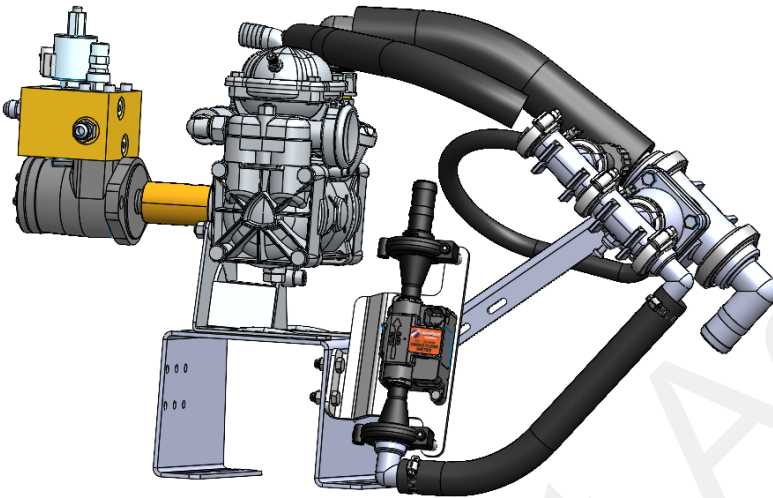

6-Pin Deutsch connector

Use adapter 201-5954Y1 to connect to 3-pin AMP Superseal harness.

OR Alternate adapter 201-6647Y1 to connect to 3-pin MP Shroud

Electromagnetic flowmeters are superior to traditional turbine flowmeters in two basic ways. First, they have no moving parts. This translates into no wear items or potential for contaminants to jam a spinning turbine.

Second, electromagnetic flowmeters detect the flow by electrically measuring the velocity of the liquid, which makes them less sensitive to viscosity or density of the fluid measured. They are generally extremely accurate using the standard calibration number, but the user must verify this.

SurePoint recommends you perform a catch test to verify the system is properly installed and configured. Adjust the flow cal as needed based on accurate catch tests with the actual product or observation of gallons applied and acres worked.

Flowmeter Model	Pulses per gallon	FPT Size	Hose Barb In kit
0.2 - 24 GPM	4542	3/4"	1"

NOTE: At flowrates above 17 GPM there will be in excess of 15psi of pressure loss through this meter.

24GPM of water = 30psi of pressure loss

The flowmeters will accurately read higher than the rated range.

Earlier model flowmeters (gray meters with white labels with black text) have different calibration numbers. The flow cal number (pulses per gallon) is printed on the serial number sticker on the side of the flowmeter.