

396-5477Y1

SENTINEL 

ROW CONTROL

INSTALLATION GUIDE

&

OPERATOR'S MANUAL

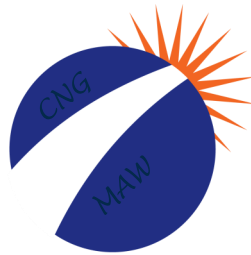

SurePoint
Ag Systems

SurePoint Ag Systems



Table Of Contents

Introduction

- Safety 2-3

Components - Modules, Wiring, Mounting

- Parts and Fittings 4-5
- Harness Overview / Layout..... 6-7
- Row Control Valve Interface Module 8
- Sentinel Module and Valve Mounting Options 9-14
- Harness Drawings - 5022 - Rate Control /Row Monitoring..... 15-20
- Connector Pinouts - 5022 21
- CAN Trunklines, Front ISO Extension 22-23
- Mounting PumpRight pump, Hydraulic and Plumbing Connections 24-29

Setup & Operation

- Getting Sentinel on VT 30-31
- Sentinel Icons 32
- **Sentinel Row Control & Row Monitoring Setup..... 33-49**
- Setup Overview 34-35
- Settings - Product - Device Setup 36
- Sections, Rows, Tolerance, Rates, Smoothing 36-37
- Implement, Speed , Hardware (Foot switch, Height switch), Task Control 38
- Rate Setup, Smoothing, Flow Adjustment, 2 product setup..... 39(37)
- Flow Module Addressing and Valve Module Addressing..... 40
- Customizing Scans and Alarms, Flow Module Diagnostics 41
- Setup Settings for Row Control - Control Speed, Flow Cal, PWM Max 42
- Valve Setup and Row Detail Screen 43
- Software Version, Auxiliary Settings, Feature Unlock Code 44
- Customizable Toolbar, Totalizer Counters 45
- Row Control Run Screen and Operation and Setup Summary..... 46-48
- Nozzle Test - Test with Simulated Speed and Rate 49
- Manual Section Valve Operation..... 50
- Manual Pump Operation 50
- Auto Test - Run with simulated speed and rate..... 50
- **Troubleshooting..... 50-53**
- Winterization, Pump Oil Change 54
- Replacing Valves and Diaphragms 54
- Pre-season Service..... 55
- Pump Assembly and Part Breakdowns 56-58
- PWM Valve and Motor Parts..... 59

Specifications and features may change and may be different from what is shown here. Setup for any particular system may be different from what is described here.



Safety

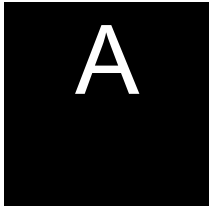

TAKE NOTE! THIS SAFETY ALERT SYMBOL FOUND THROUGHOUT THIS MANUAL IS USED TO CALL YOUR ATTENTION TO INSTRUCTIONS INVOLVING YOUR PERSONAL SAFETY AND THE SAFETY OF OTHERS. FAILURE TO FOLLOW THESE INSTRUCTIONS CAN RESULT IN INJURY OR DEATH.



**THIS SYMBOL MEANS
ATTENTION!
BECOME ALERT!
YOUR SAFETY IS INVOLVED!**

Note the use of the signal words DANGER, WARNING and CAUTION with the safety messages. The appropriate signal word for each has been selected using the following guidelines:



DANGER: Indicates an imminently hazardous situation that, if not avoided, will result in death or serious injury. This signal word is to be limited to the most extreme situations typically for machine components which, for functional purposes, cannot be guarded.



WARNING: Indicates a potentially hazardous situation that, if not avoided, could result in death or serious injury, and includes hazards that are exposed when guards are removed. It may also be used to alert against unsafe practices.



CAUTION: Indicates a potentially hazardous situation that, if not avoided, may result in minor or moderate injury. It may also be used to alert against unsafe practices.

NOTICE is used to address safety practices not related to personal safety.





Hydraulic Fluid and Equipment Safety

This system uses hydraulic equipment with hydraulic fluid under extremely high pressure.

Hydraulic fluid escaping under pressure can have sufficient force to penetrate the skin causing serious injury. Keep all hoses and connections in good serviceable condition. Failure to heed may result in serious personal injury or death. Avoid the hazard by relieving the pressure before disconnecting lines or performing work on the system.

Make sure hydraulic fluid connections are tight and all hydraulic hoses and lines are in good condition before applying pressure to the system. Use a piece of paper or cardboard, NOT BODY PARTS, to check for suspected leaks. Wear protective gloves and safety glasses or goggles when working with hydraulic systems. DO NOT DELAY!

Check hydraulic hoses and fittings frequently. Loose, broken, and missing hardware can cause equipment to not perform properly and can result in serious injury or death.

Hydraulic systems can be hot and cause burns. Before working on any system, wait until the fluid has cooled.

If an accident occurs, see a doctor familiar with this type of injury immediately. Any fluid injected into the skin or eyes must be treated within a few hours or gangrene may result.



A Word to the Operator

It is YOUR responsibility to read and understand the safety messages in this manual. YOU are the key to safety.

SAFETY IS YOUR RESPONSIBILITY.

Parts and Fittings



ITEM NO.	PART NUMBER	DESCRIPTION
1	204-01-4625AAGB1B1	Sentinel™ Flowmeter Module
2	120-T3MT3F-4XT1M	T3 Male/Female Manifold w/ (4)T1 Male Outlets
3	124-02-010003	T3 Fork
4	120-T3FTEE	T3 Tee
5	120-T3MPLUG	T3 Male FC Plug
6	124-02-010004	T4 Fork
7	120-T4FT3FRC	T4 Female x T3 Female FC Reducer Coupling
8	120-T4MT3MRN	T4 Male x T3 Male FC Reducer Nipple
9	121-T3M075-90	T3 Male FC x 3/4" HB - 90 degree
10	121-T3F075	T3 Female x 3/4" HB
11	124-01-G11056-V	Viton O-Ring for T1 fittings
12	124-01-G11058-V	Viton O-Ring for T3 fittings
13	124-01-G11054-V	Viton O-Ring for T4 fittings

See next page for a list of T1 fittings

Parts and Fittings

for
Isolated Rows



Commonly used Quick-Connect (QC) Fittings

Part Number	Description
113-12-038038	Stem Elbow—3/8" Stem x 3/8" QC
113-05-025	Plug - 1/4" QC
13-05-038	Plug - 3/8" QC

T1 Fittings

Part Number	Description
120-T1M038QC	T1 Male x 3/8" QC
120-T1M025QC	T1 Male x 1/4" QC
121-T1M038	T1 Male x 3/8" HB
121-T1M050	T1 Male x 1/2" HB
124-01-G11056-V	Viton O-ring for T1 Fittings

Sentinel Flow Meter

Part Number	Description
204-01-4625AAGB1B1	4-Row Sentinel flow meter
124-02-010001	T1 Fork
374-4024Y1	4-Pin Amp Superseal dust plug
384-1105	Hardware Kit - mounting bolts

SurePoint Harness Layout for ISO Sentinel

C

Components

The SurePoint Sentinel module communicates with the Sentinel ECU through a proprietary communication network (CAN). The Sentinel ECU then, using the ISOBUS communication protocol, relays the flow information through the tractor ISOBUS and generates the user interface on the in-cab display. A series of connections are required to form this communication network.

Tractor Connection

Designed to integrate with any implement, in some cases, connecting the Sentinel starts at the tractor's ISOBUS connection. Power and information is relayed to the Sentinel ECU using a SurePoint Front ISO Extension which includes power and CAN bus connections. Already using the tractor ISOBUS? No Problem. SurePoint carries ISOBUS-Y harnesses to split the ISO connection at the tractor.

Implement Height and Speed Input

Not used in all configurations, the implement height and speed input connections provide additional input options in situations that require advanced alarm control and an auxiliary speed source. These conditions generally exist only in hybrid systems, utilizing multi-branded components.

Service Connections

The Terminating Resistor, Programming and RS232 connectors are for service only and should not be used.

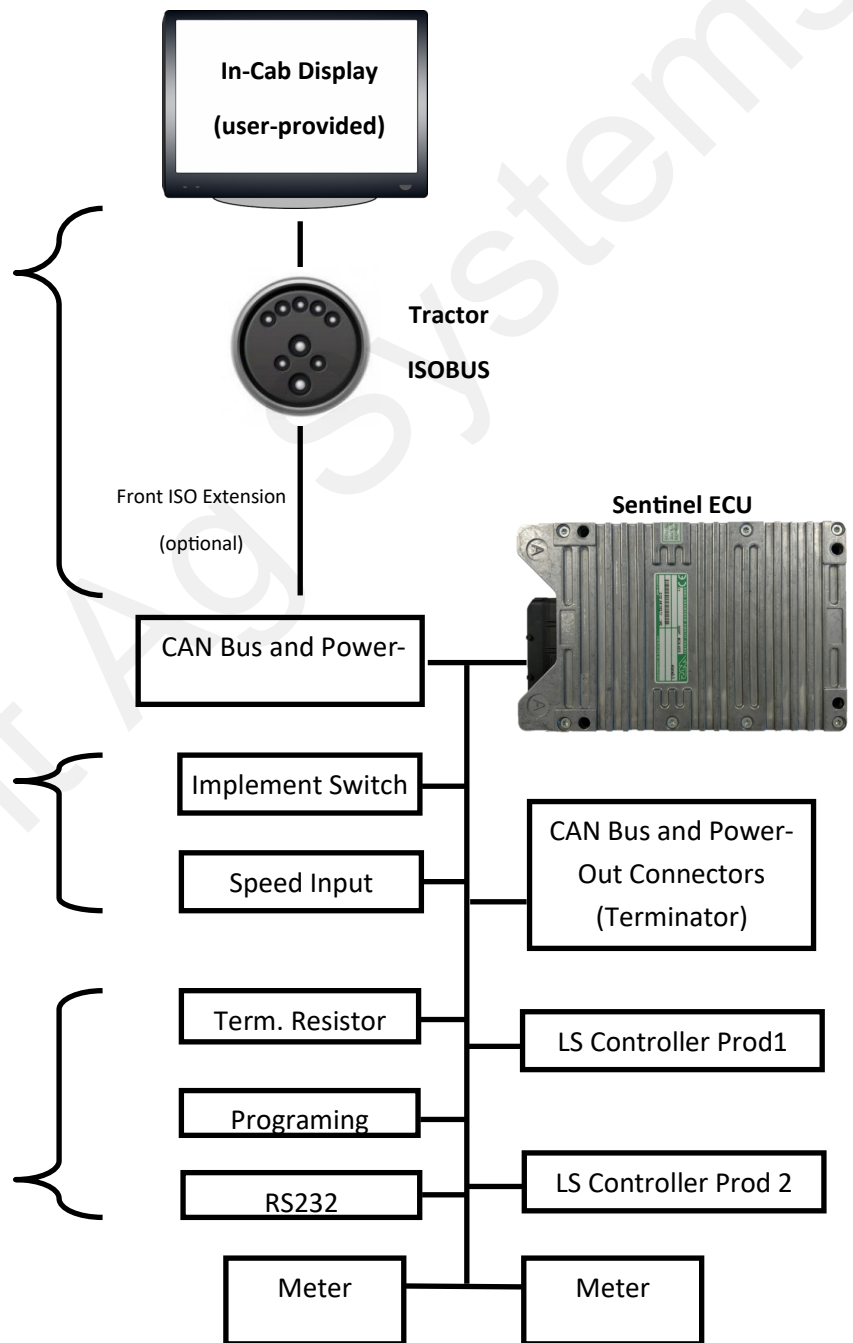

Bus Connections

2 Bus connections are provided for convenience so that each side of the implement can plug into the ECU harness without the need for a long, continuous chain of connections.

SurePoint Harness Layout for ISO Sentinel

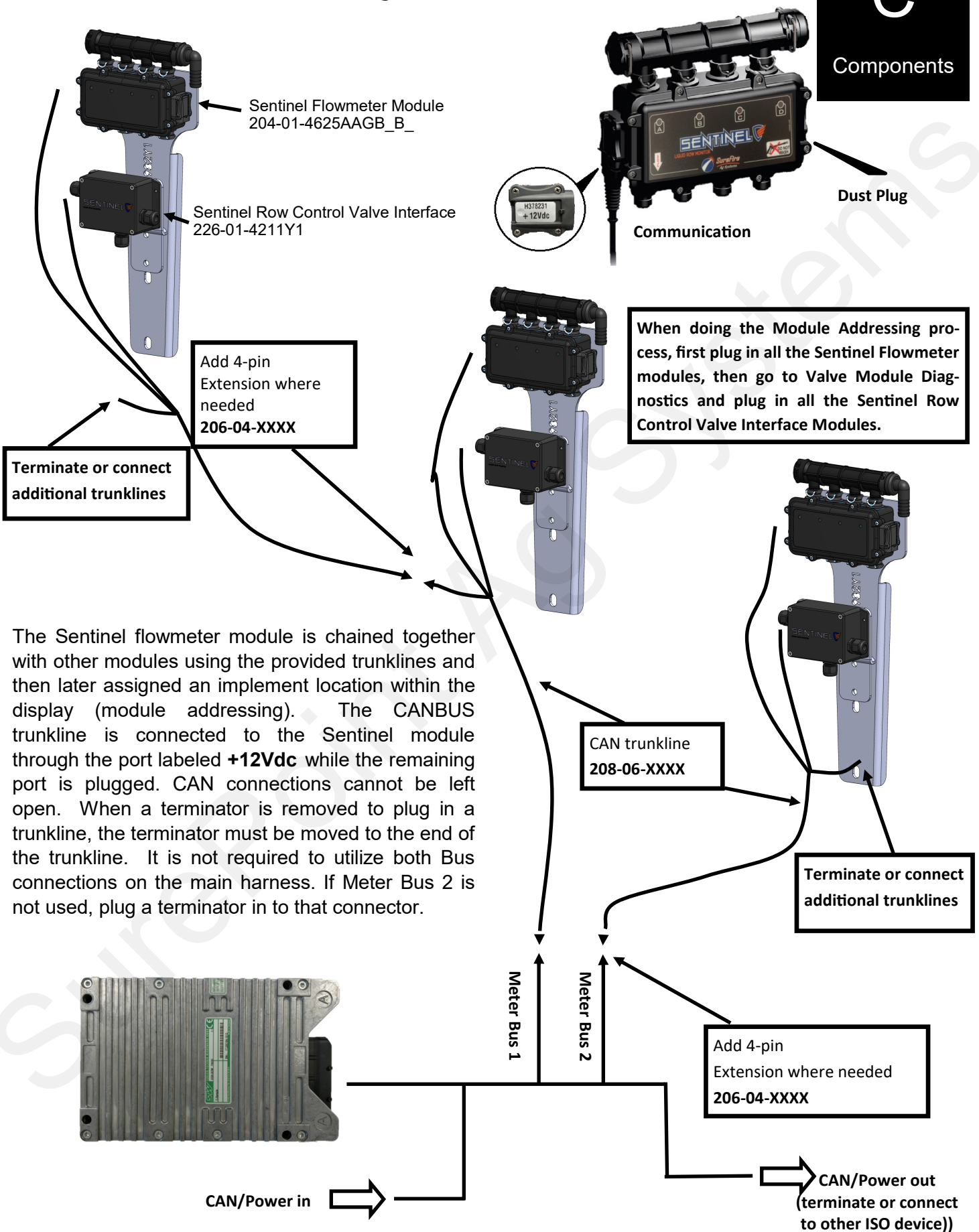
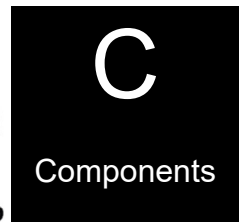

The Sentinel flowmeter module is chained together with other modules using the provided trunklines and then later assigned an implement location within the display (module addressing). The CANBUS trunkline is connected to the Sentinel module through the port labeled **+12Vdc** while the remaining port is plugged. CAN connections cannot be left open. When a terminator is removed to plug in a trunkline, the terminator must be moved to the end of the trunkline. It is not required to utilize both Bus connections on the main harness. If Meter Bus 2 is not used, plug a terminator in to that connector.

Sentinel Row Control Valve Interface 226-01-4211Y1

CANBUS - Connect to Trunkline (CANBUS Device connector) during Module addressing process



VALVE A - B - C - D
Connect to the correct row control valve (*match A - B - C - D with the Sentinel Flowmeter module plumbing for each row*)

CANBUS - Connect to Trunkline during Module addressing process

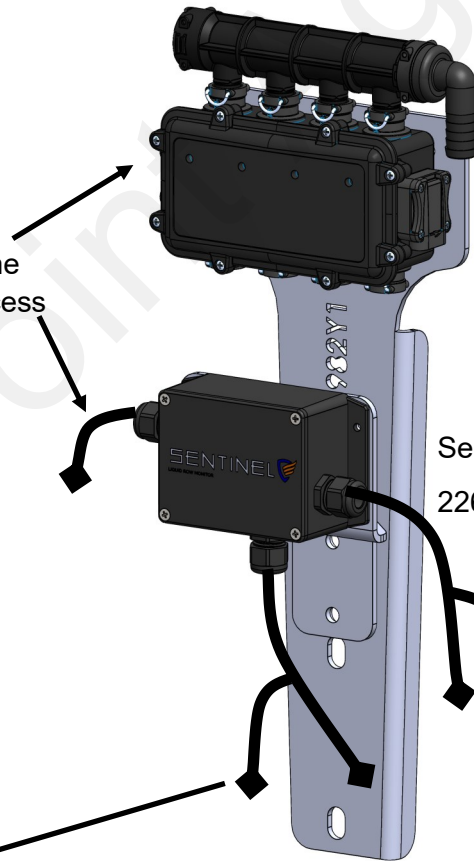

Sentinel Flowmeter Module
204-01-4625AAGB_B_

Sentinel Row Control Valve Interface
226-01-4211Y1

Connect to Valves A & B

Connect to Valves C & D

Individual Row Control Valve

Sentinel Row Control Valve Interface Installation:

1. Mount the Low-Profile Sentinel Flow Module Mounting Bracket (400-3982Y1) to the toolbar, typically in the center of 4 rows if possible, using provide u-bolts.
2. Mount the Sentinel Row Control Valve Interface to the Sentinel Row Control Valve Interface Mounting Bracket (400-4956Y1-BK) using the mounting hardware bag (384-1110 - Size 10 machine screws, flat washers, and nylon lock nuts). *Note: The Valve Interface bracket can mount to the front or back of the flowmeter mounting bracket.*
3. Mount the valve interface assembly to the Sentinel Row Monitoring mounting bracket using hardware kit (384-1130 - 3/8" hex head bolt and flange nut)
4. Mount the Sentinel Row Monitor flowmeter module to the mounting bracket using hardware kit (384-1105 - 5/16" hex head bolts and flange nuts). *See plumbing assembly, next page. It may be desired to assemble plumbing prior to mounting to the bracket.*
5. Route CAN trunkline harness and connect the AMP Superseal Connectors to the Flowmeter module and valve interface CANBUS connector. Secure wiring harness with zip ties as needed. Make sure to allow clearance for row unit travel and/or wing fold points.

*See next pages for plumbing installation.

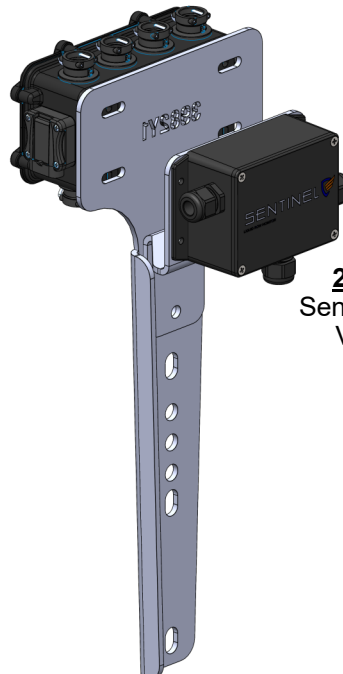
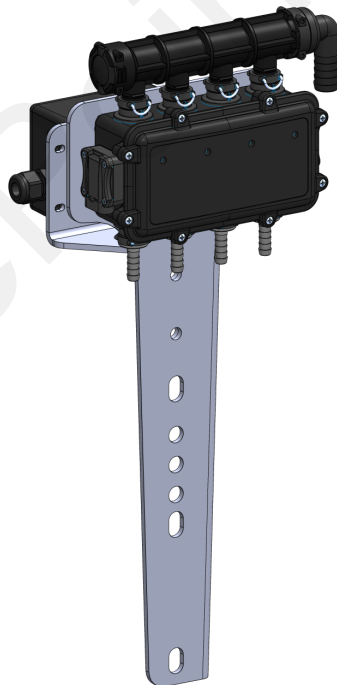
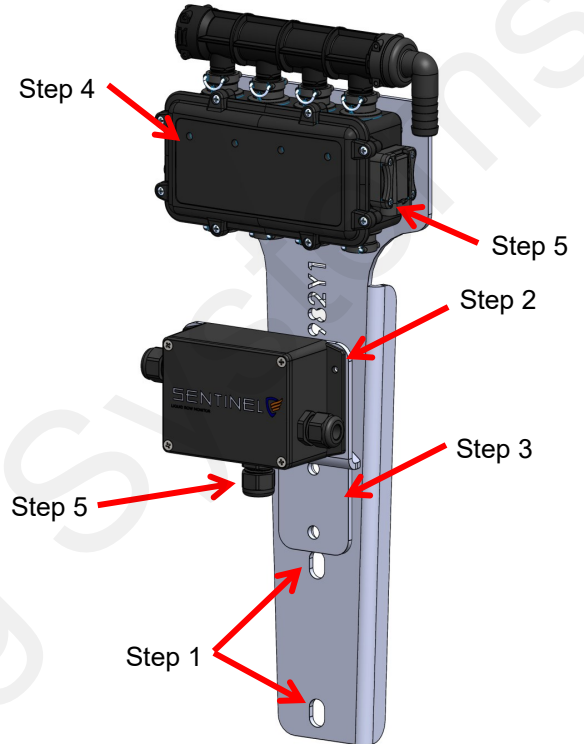

226-01-4211Y1
Sentinel Row Control
Valve Interface

Valve Interface Mounted to Rear of mounting bracket

Flowmeter Module Plumbing Installation:

1. Mount the Sentinel Row Monitor flowmeter module to the mounting bracket using hardware kit (384-1105 - 5/16" hex head bolts and flange nuts).
2. Lubricate O-rings prior to installation in insert the inlet manifold (120-T3MT3F-4XT1M) into the top ports of the flowmeter module, flow direction is down. Install fork fittings to secure the manifold in place.
3. Insert the male plug (120-T3MPLUG) into the end of the manifold. Secure with fork fitting.
4. Install the female 3/4" hose barb elbow fitting (121-T3F075-90) onto the inlet of the manifold. Secure with fork fitting.
5. Insert the outlet 3/8" hose barb fitting (121-T1M038) into the bottom ports of the flowmeter and secure with fork fitting.

**Lubricate all o-rings prior to installation to prevent rolling, stretching or tearing the o-ring and causing leaks.*

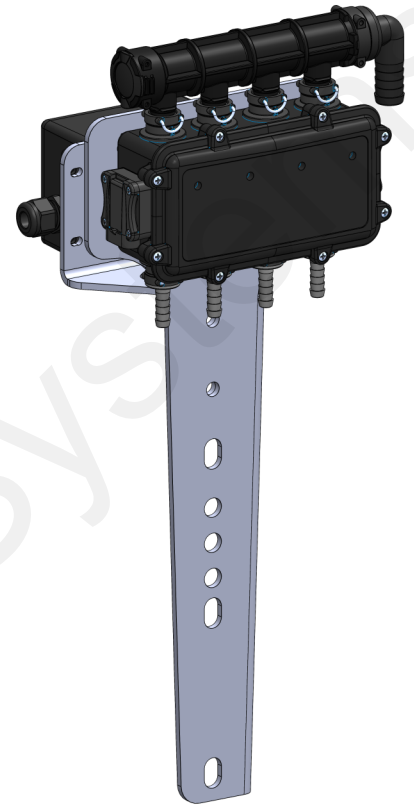

120-T3MT3F-4XT1M

T3 Male and Female FC 4 Way
Manifold w/ T1 Male Outlets

121-T3F075-90

T3 Female FC x 3/4" HB - 90 degree

120-T3MPLUG

T3 Male FC Plug

Step 3

Step 2

Step 4

Step 1

Step 5

204-01-4625AAGB1B1

4 Row Electromagnetic Sentinel
Flowmeter (.08 - 1.6 GPM)

121-T1M038

T1 Male FC x 3/8" HB

ROW CONTROL

General Installation Notes:

1. Mount the Pump on the planter hitch, or in a centralized location at the rear of the planter or on the tractor. Route 3/4" or 1" discharge hose to the center of the planter and tee for each wing.
2. Mount the Sentinel ECU (226-01-3547Y1) according to 396-5337Y1 instruction sheet in a central location near the pump.
3. Distribute Sentinel Flowmeter / Valve Interface Modules evenly across the toolbar, in the center of every 4 rows if possible.
4. Route the 3/4" supply hose to the inlet port of the Sentinel Row Monitor Flowmeter Module manifold.
5. Route 3/8" OD tubing or 3/8" hose from the Sentinel Flowmeter Module to the Sentinel Row Control Valve located near the row unit. *Note: Lubricate 3/8" tube or tube fitting and make sure 3/8" OD tubing is cut off flush and clean prior to installation to avoid rolling the o-ring.*

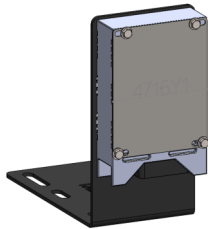

515-00-100900

Sentinel ISOBUS ECU Slim
Mounting Bracket Kit

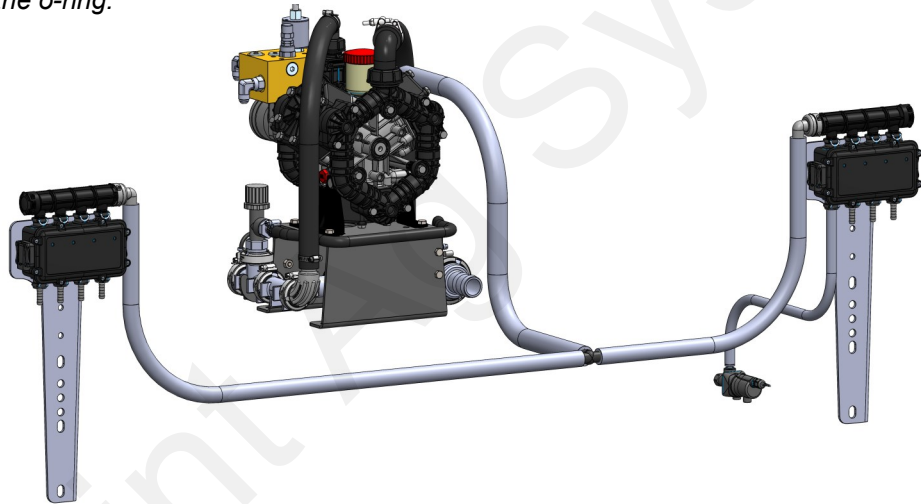

527-08-100100 - 8 Row Sentinel Row Control Plumbing Kit

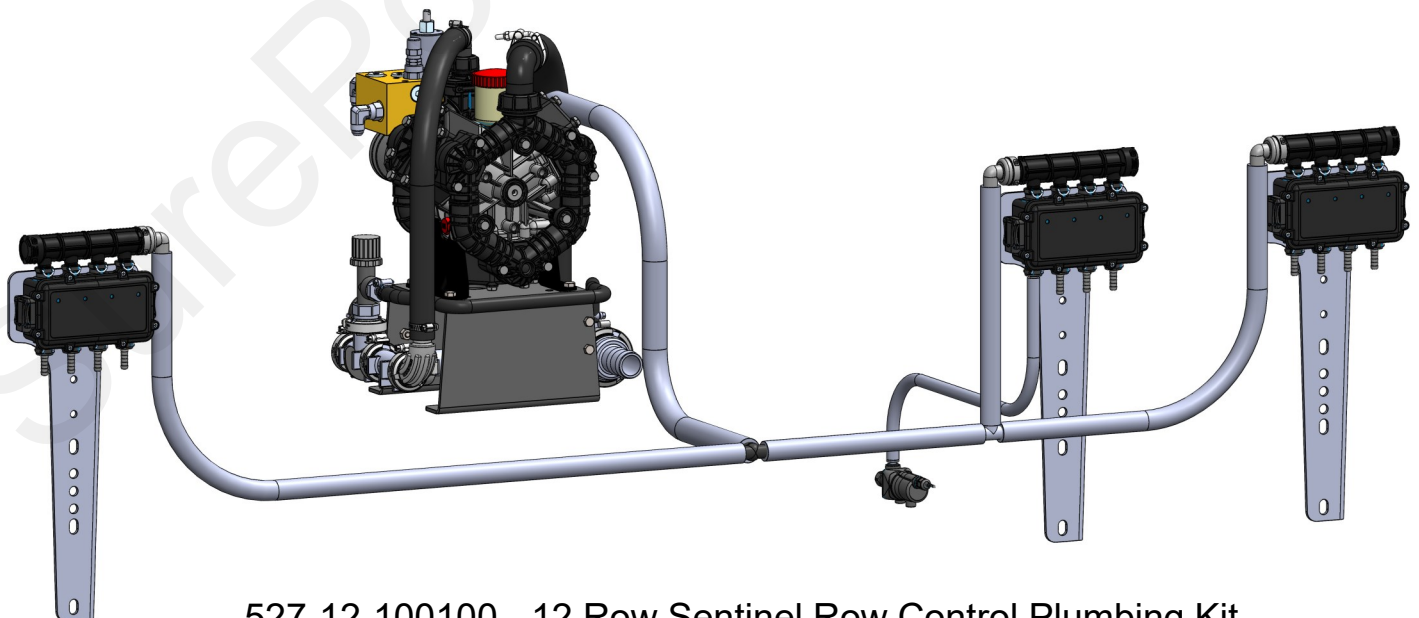

527-12-100100 - 12 Row Sentinel Row Control Plumbing Kit

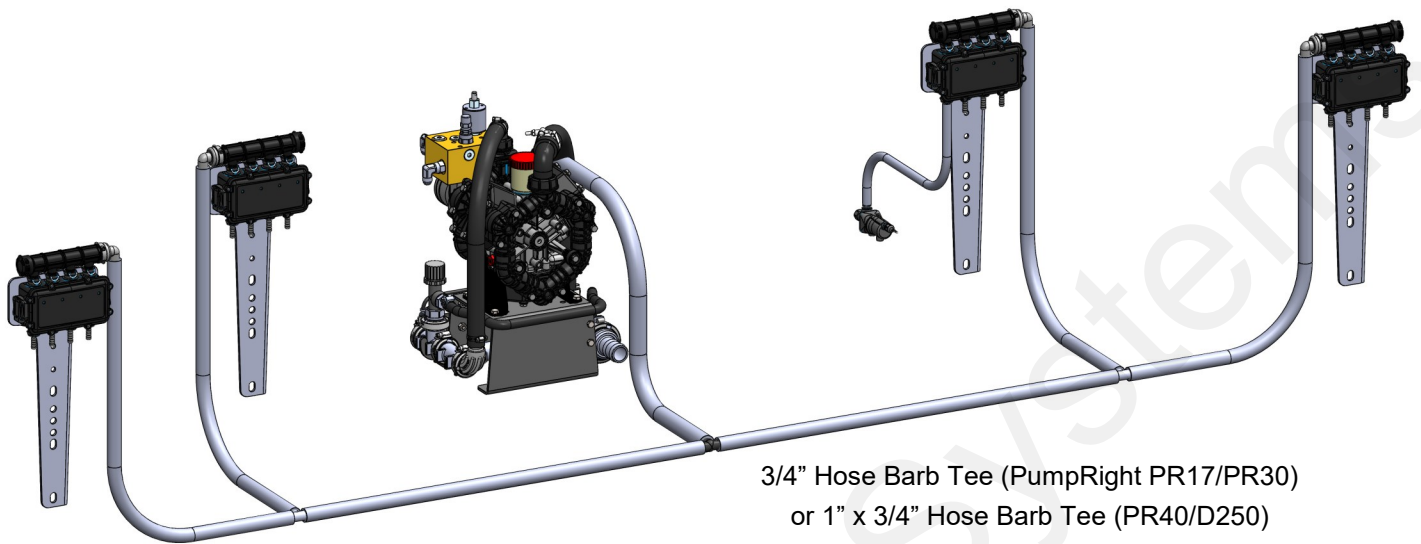

3/4" Hose Barb Tee (PumpRight PR17/PR30)
or 1" x 3/4" Hose Barb Tee (PR40/D250)

527-16-100100 - 16 Row Sentinel Row Control Plumbing Kit

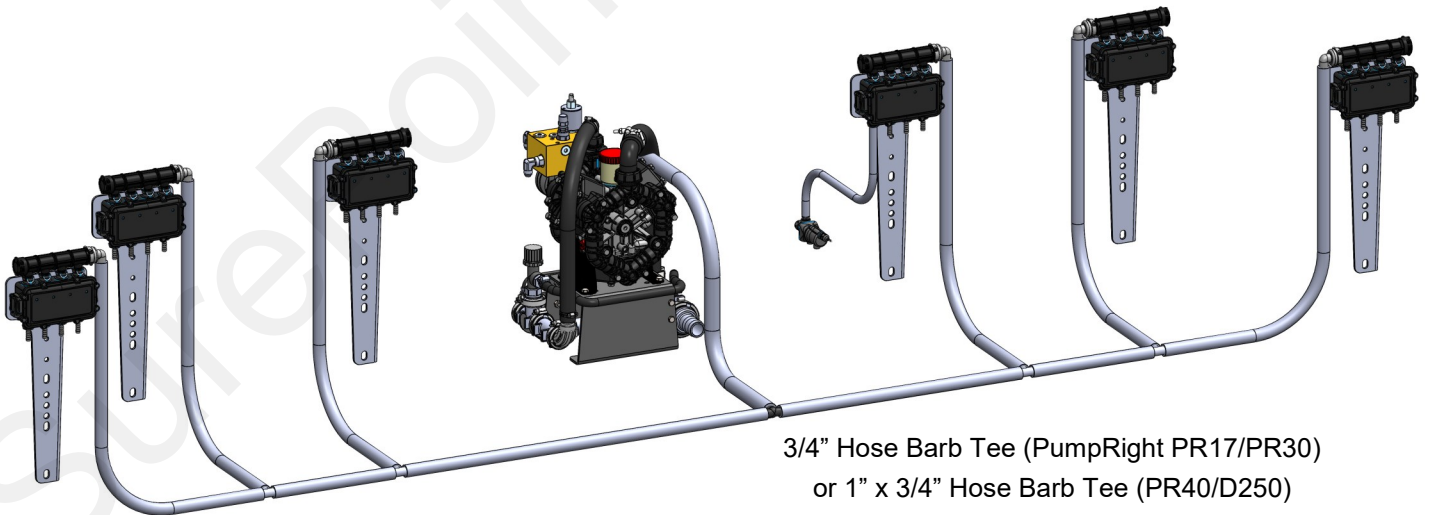

3/4" Hose Barb Tee (PumpRight PR17/PR30)
or 1" x 3/4" Hose Barb Tee (PR40/D250)

527-24-100100 - 24 Row Sentinel Row Control Plumbing Kit

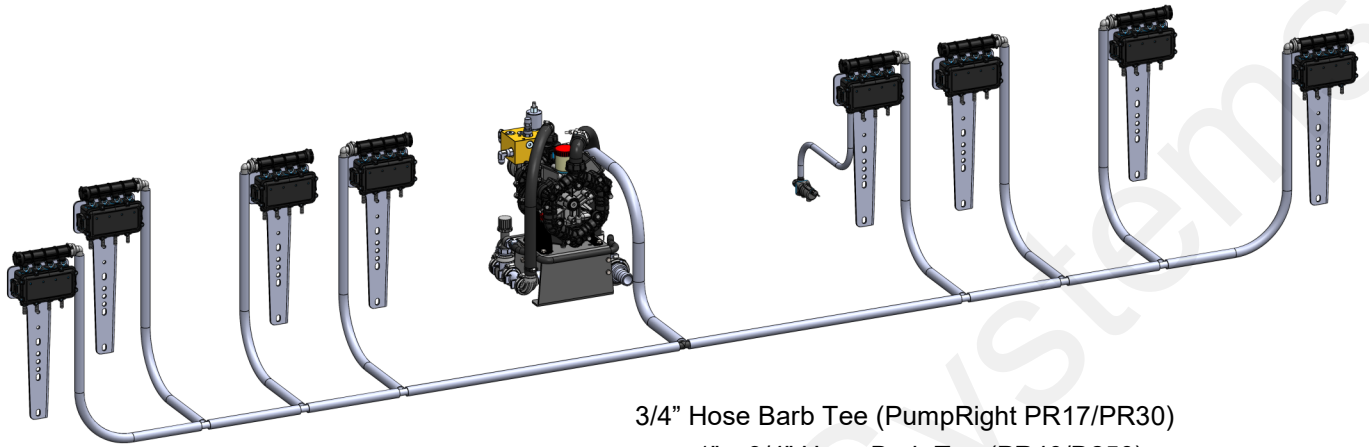

3/4" Hose Barb Tee (PumpRight PR17/PR30)
or 1" x 3/4" Hose Barb Tee (PR40/D250)

527-32-100100 - 32 Row Sentinel Row Control Plumbing Kit- PR17, PR30 Kit

527-32-100200 - 32 Row Sentinel Row Control Plumbing Kit- PR40, D250, PR80 Kit

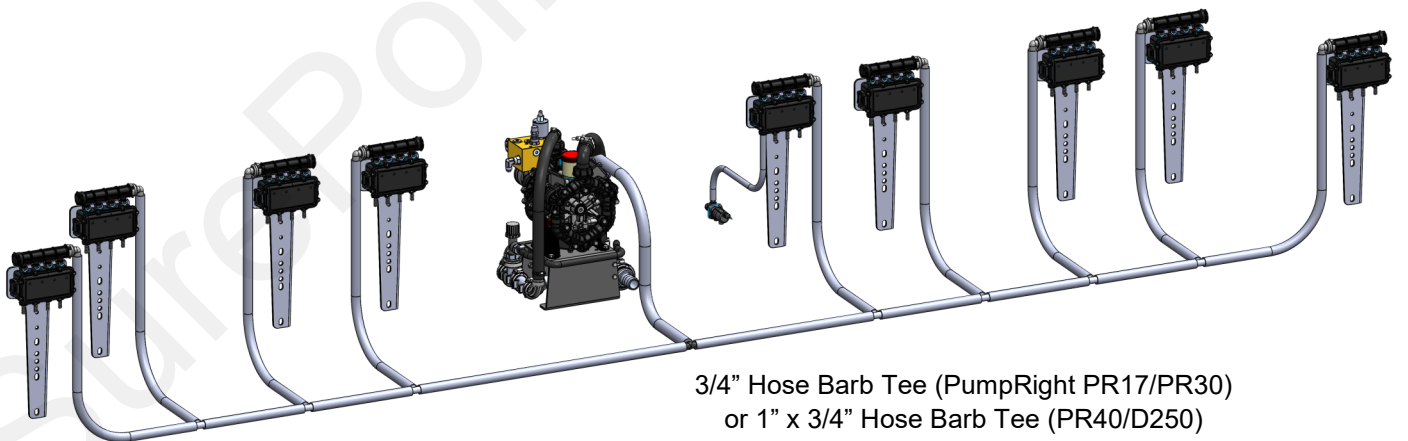

3/4" Hose Barb Tee (PumpRight PR17/PR30)
or 1" x 3/4" Hose Barb Tee (PR40/D250)

527-36-100100 - 36 Row Sentinel Row Control Plumbing Kit- PR17, PR30 Kit

527-36-100200 - 36 Row Sentinel Row Control Plumbing Kit- PR40, D250, PR80 Kit

Sentinel Row Control Valve Installation:

1. Mount the Sentinel Row Control valve and mounting bracket to the planter using one of the kit options below.
2. Route 3/8" OD tubing or 3/8" hose from the Sentinel Flowmeter Module to the row unit. Avoid pinch points on the planter and allow for row unit travel. Note: Lubricate 3/8" tube or tube fitting and make sure 3/8" OD tubing is cut off flush and clean prior to installation to avoid rolling the o-ring.
3. Route harness and connect the 4-pin Deutsch connector. Secure wiring harness with zip ties as needed. Make sure to allow clearance for row unit travel and/or wing fold points.
4. Route 3/8" OD tubing or 3/8" hose from the Sentinel Row Control Valve to the placement device.

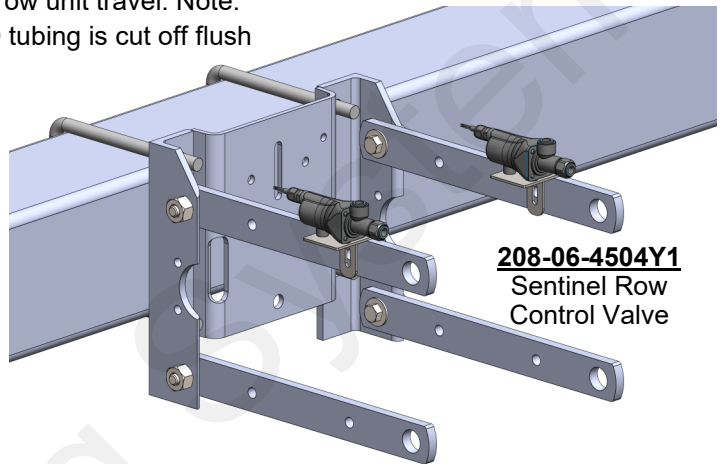

208-06-4504Y1
Sentinel Row Control Valve

515-01-400100 - Sentinel Row Control Parallel Arm Bracket Kit

Bracket and Hardware to mount the Row Control Valves to the row unit parallel arm. Can be mounted to either side, inside or outside of the parallel arms.

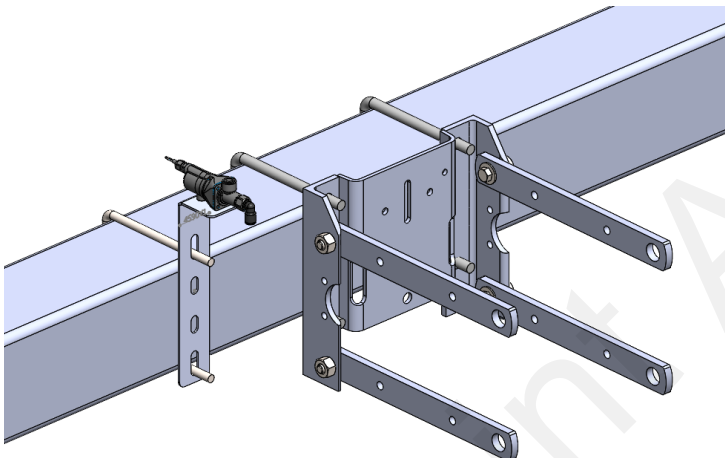

515-01-400300 - Toolbar Mounting Bracket Kit for Sentinel Row Control Valves

Bracket and Hardware to mount Sentinel Row Control Valves to toolbar (Fits up to 8x8).

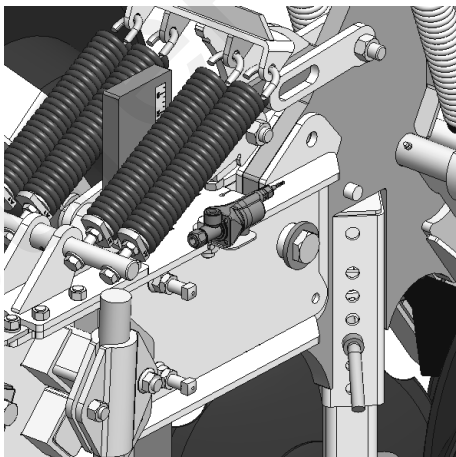

515-01-400200 - Sentinel Row Control Orthman 1TripR Mounting Bracket

Bracket and Hardware to mount the Row Control Valves

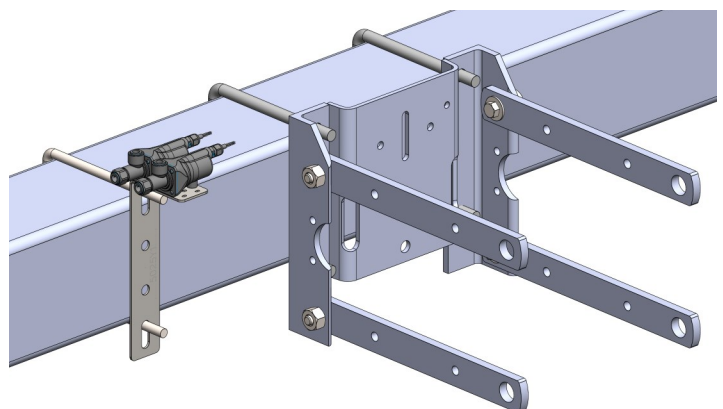

515-01-400350 - Dual Product Sentinel Row Control
Bracket and Hardware to mount Sentinel Row Control Valves to toolbar (Fits up to 8x8). Mount 2 valves to the same bracket for dual product system or reduced toolbar install footprint.

208-06-5022Y1 Sentinel Rate/Row Control ECU Harness - 2 Product - 18 Sections

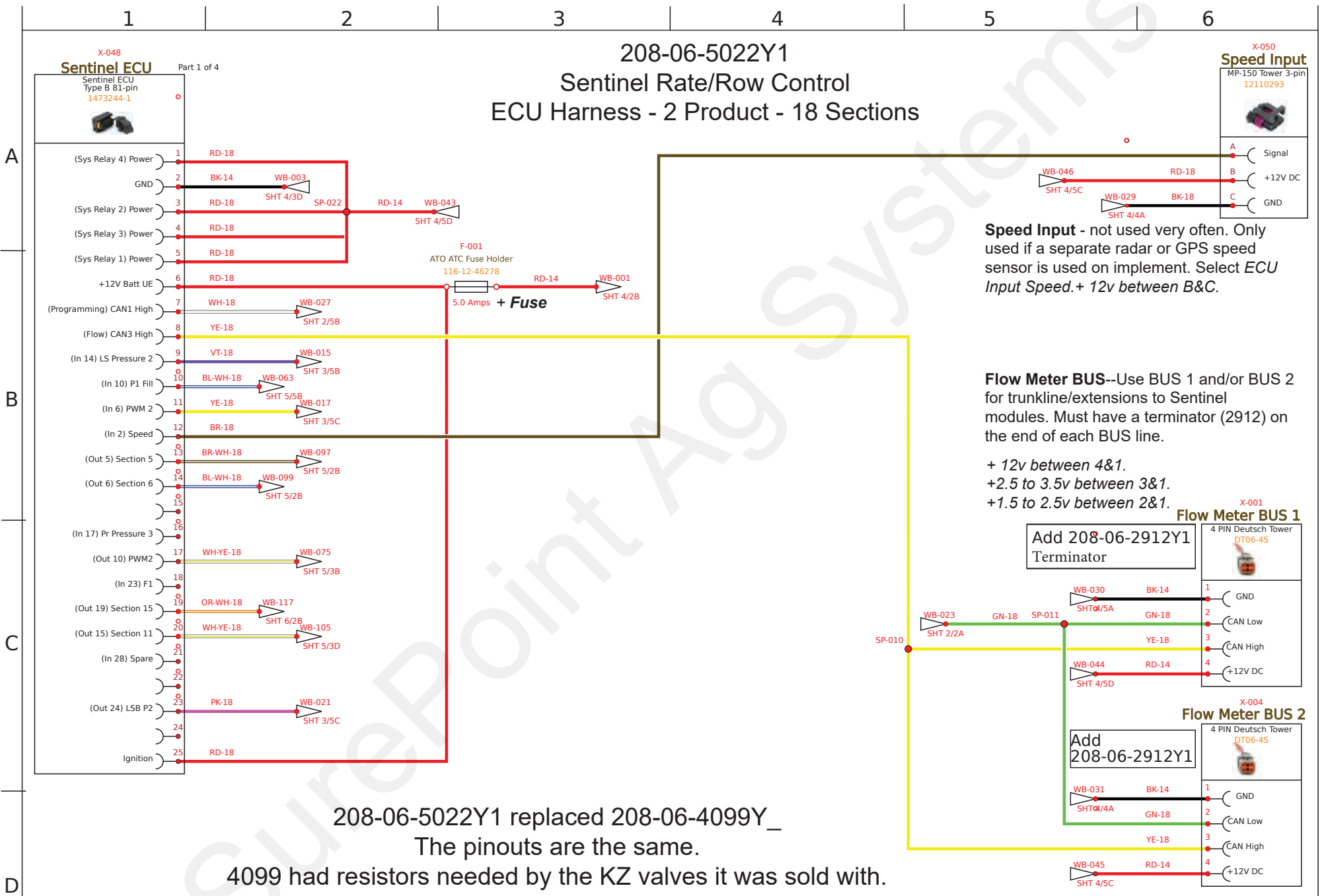

Speed Input - not used very often. Only used if a separate radar or GPS speed sensor is used on implement. Select *ECU Input Speed*. + 12v between B&C.

Flow Meter BUS--Use BUS 1 and/or BUS 2 for trunkline/extensions to Sentinel modules. Must have a terminator (2912) on the end of each BUS line.

+ 12v between 4&1.
+2.5 to 3.5v between 3&1.
+1.5 to 2.5v between 2&1.

208-06-5022Y1 replaced 208-06-4099Y1_ The pinouts are the same. 4099 had resistors needed by the KZ valves it was sold with.

1

2

3

4

5

6

208-06-5022Y1

Sentinel Rate/Row Control ECU Harness - 2 Product - 18 Sections

X-048
Sentinel ECU

Part 2 of 4

Sentinel ECU
Type B 81-pin
1473244-1

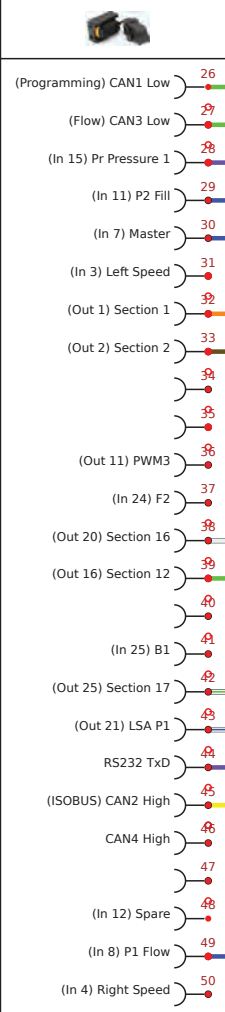

X-033
RS232

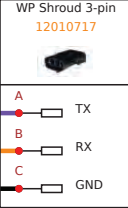

X-040
Programming

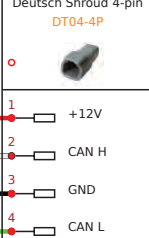

X-054
Programming CAN Term.

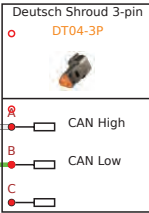

1

2

3

4

5

6

X-048
Sentinel ECU Part 3 of 4



208-06-5022Y1
Sentinel Rate/Row Control
ECU Harness - 2 Product - 18 Sections

X-003
LS Controller Product 1

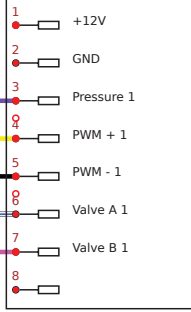

X-002
LS Controller Product 2

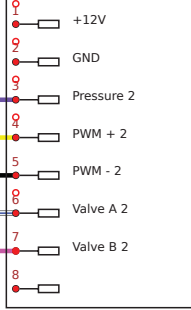

X-051
Implement Switch

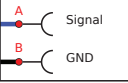

Implement Switch
+ 8.2v or 12v between B&A.
Jump between A&B for testing or emergency use.

A

B

C

D

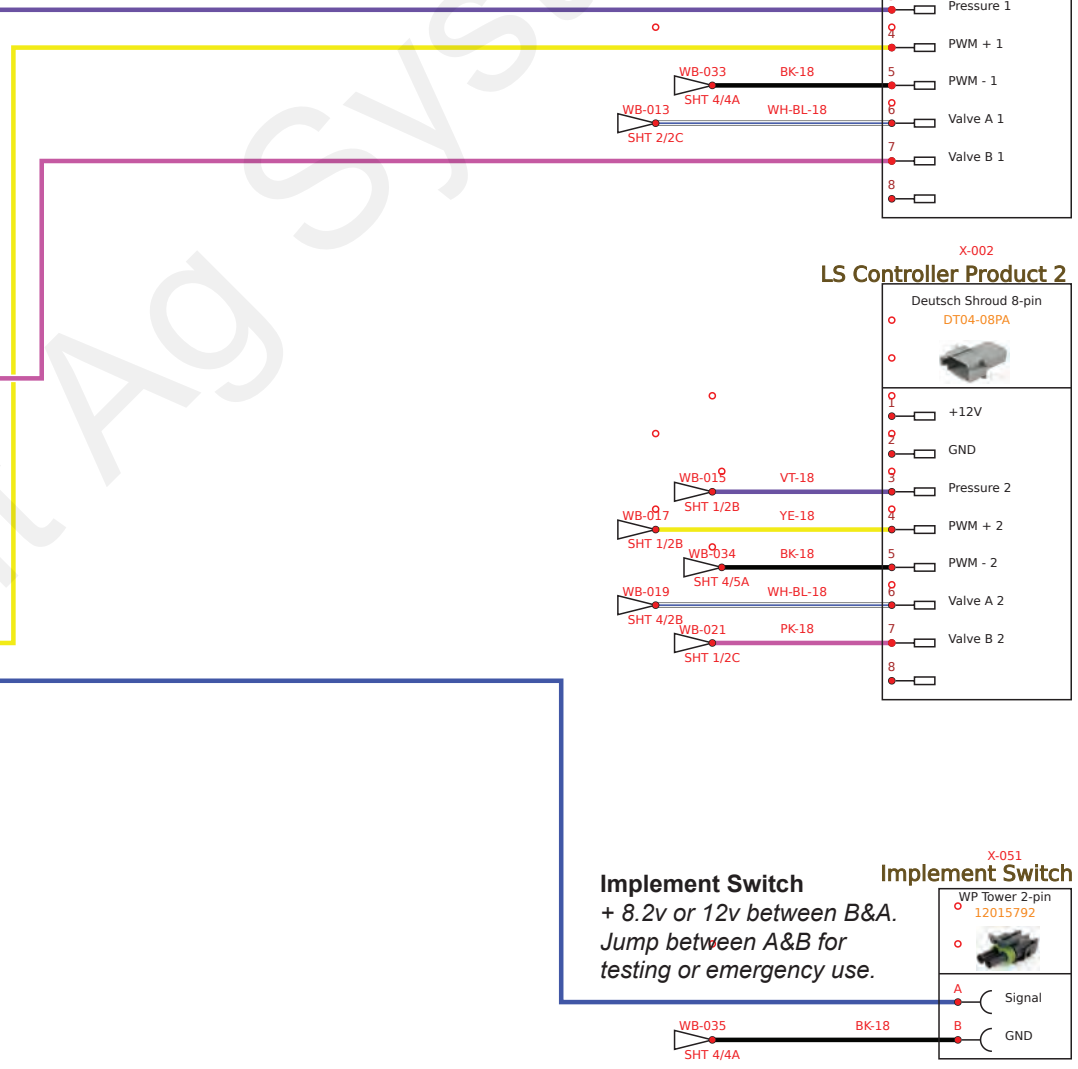
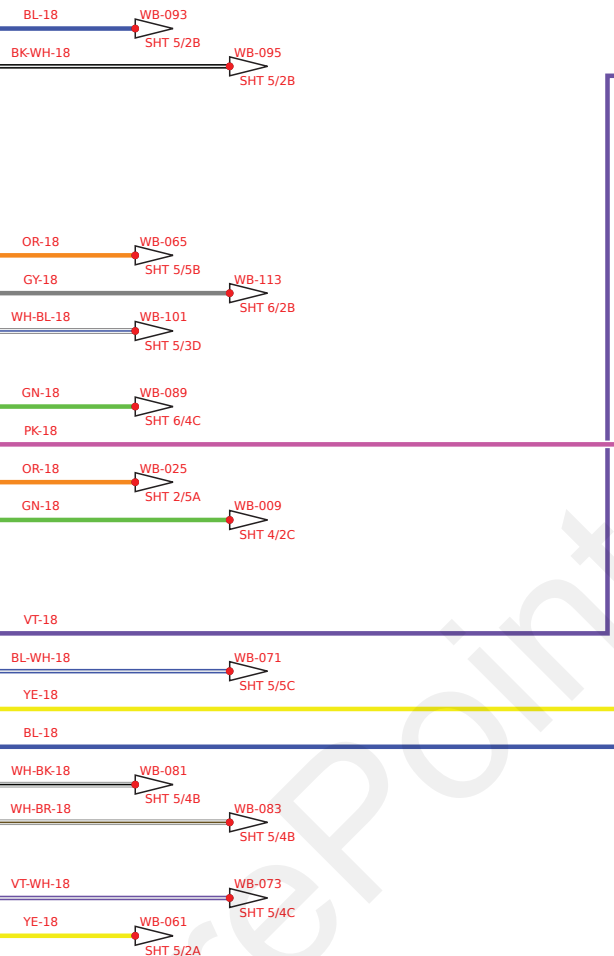
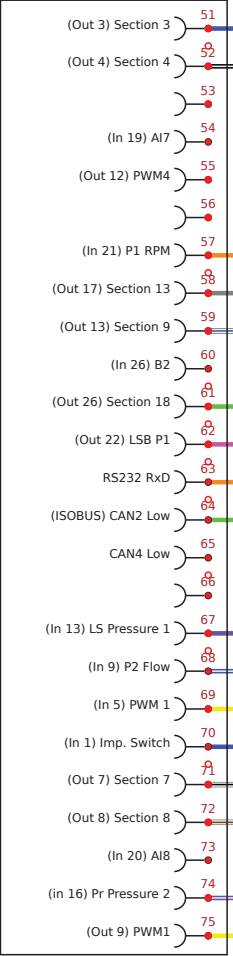

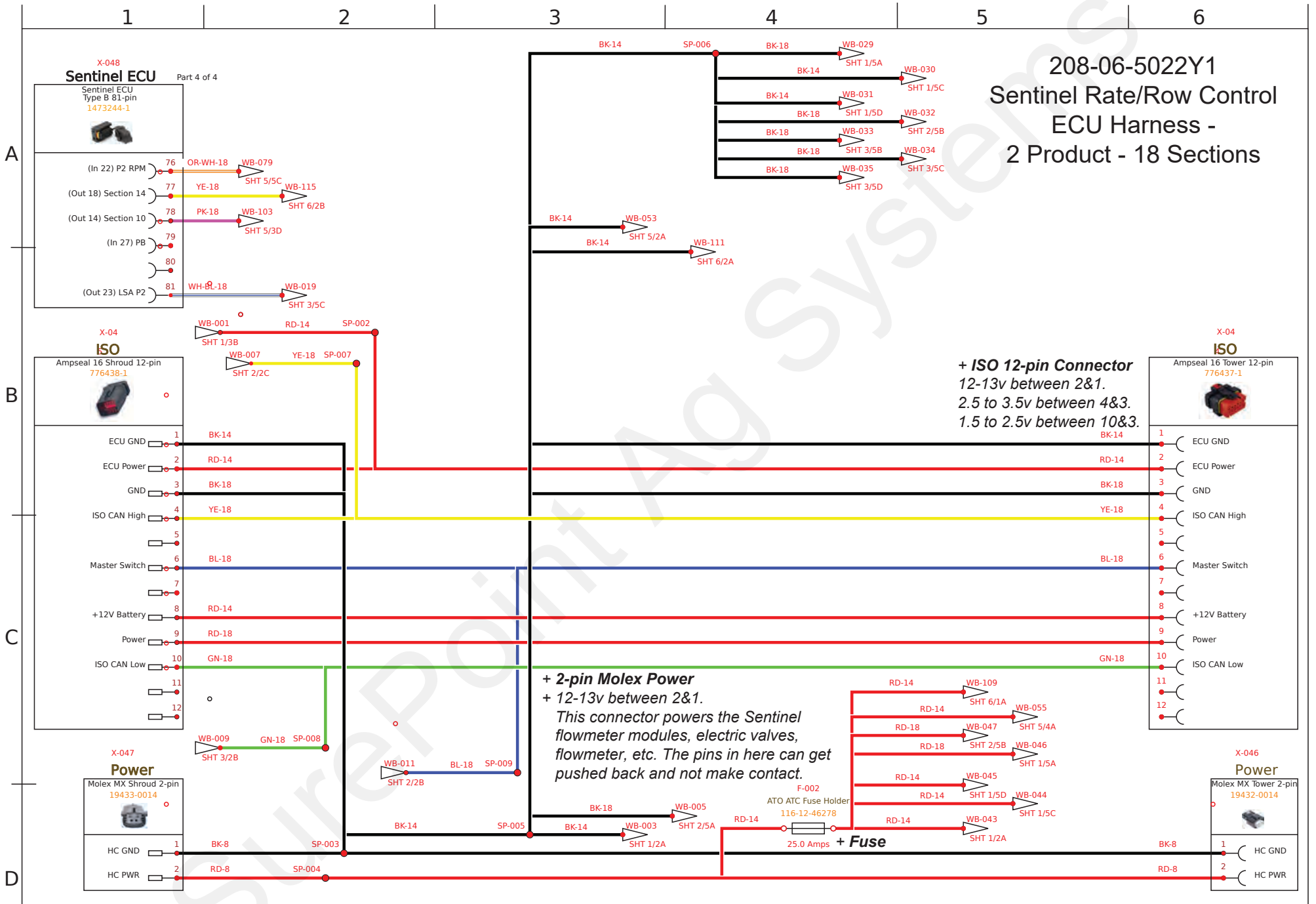

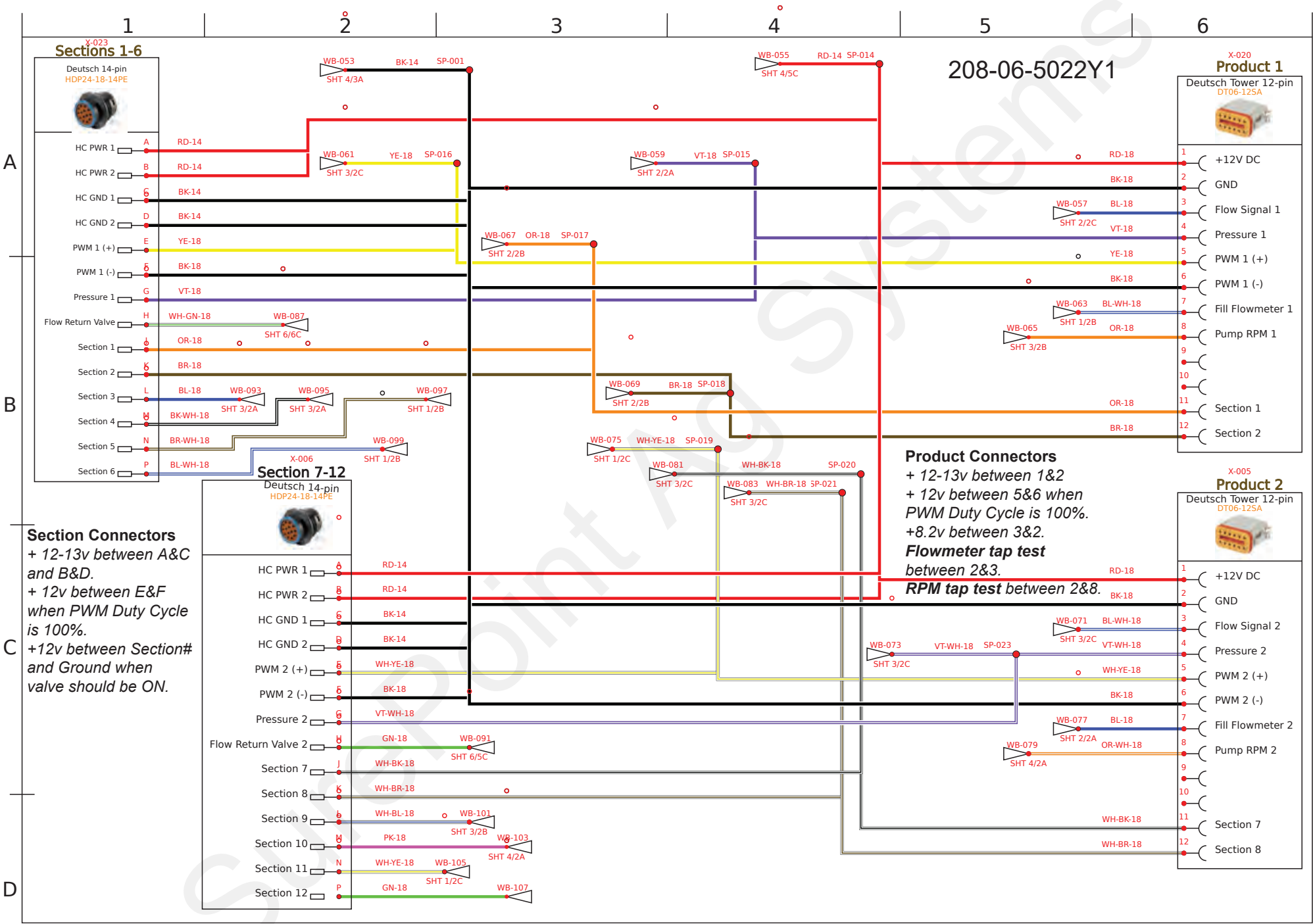

Sections 1-6

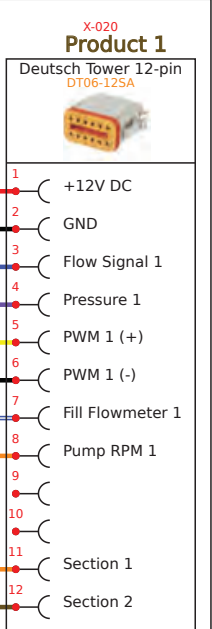
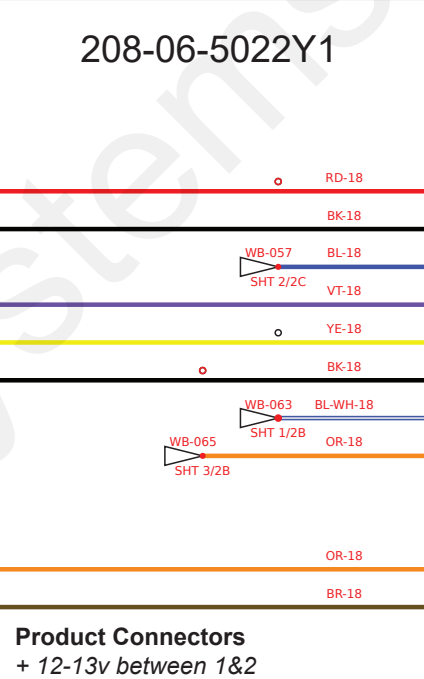
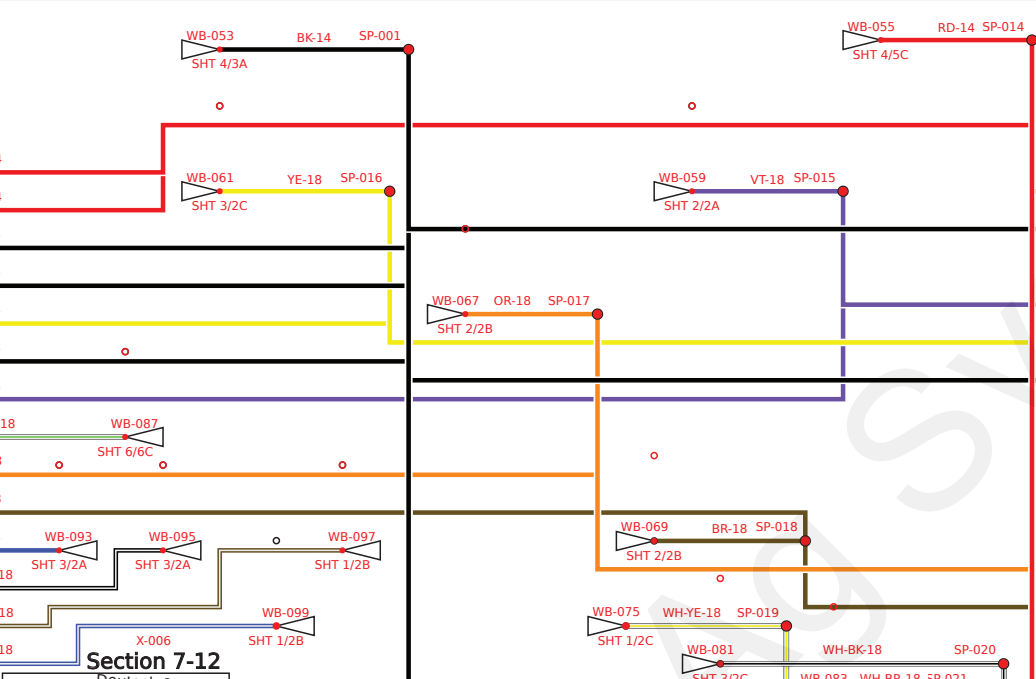
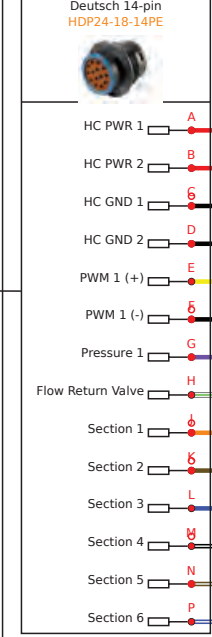

Section 7-12

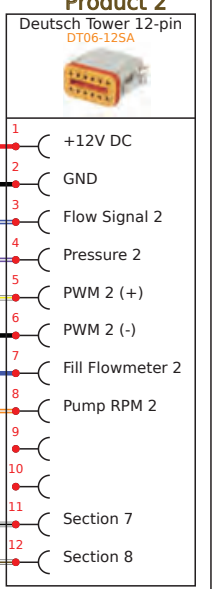
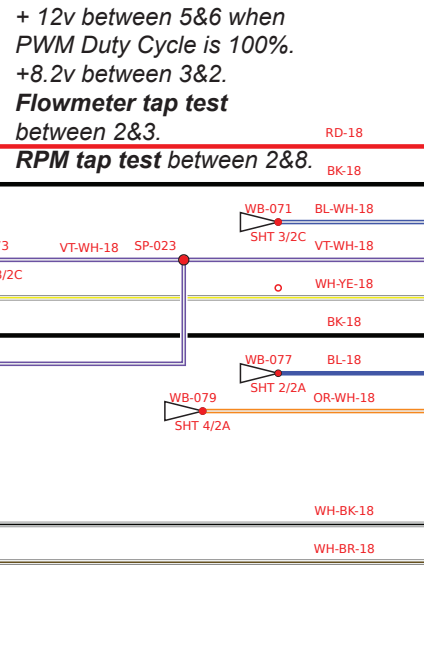
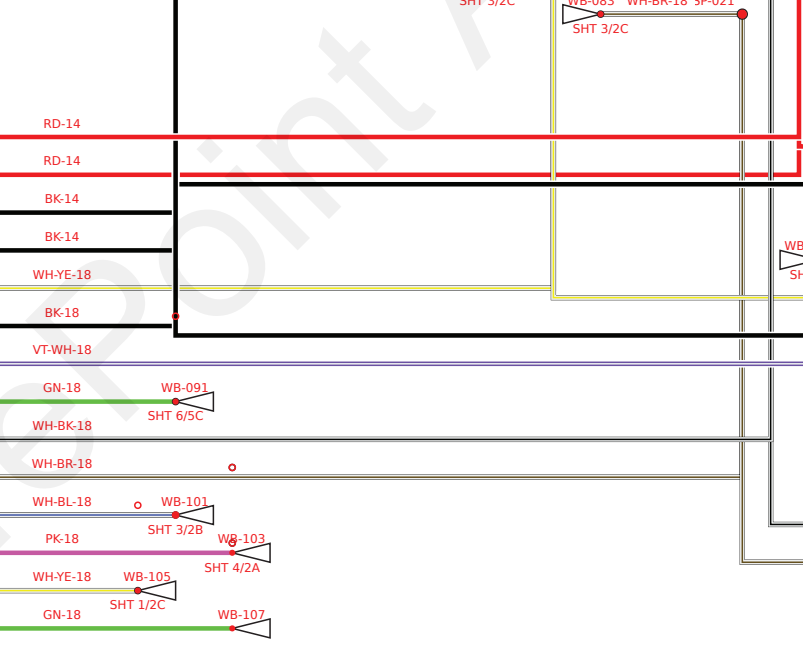
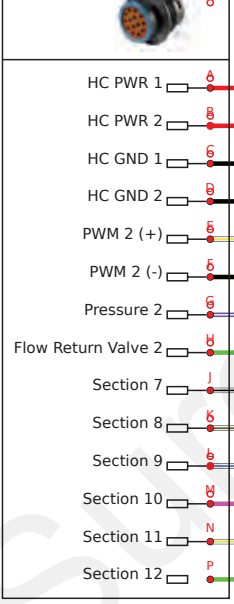

208-06-5022Y1
 Sentinel Rate/Row Control
 ECU Harness - 2 Product - 18 Sections

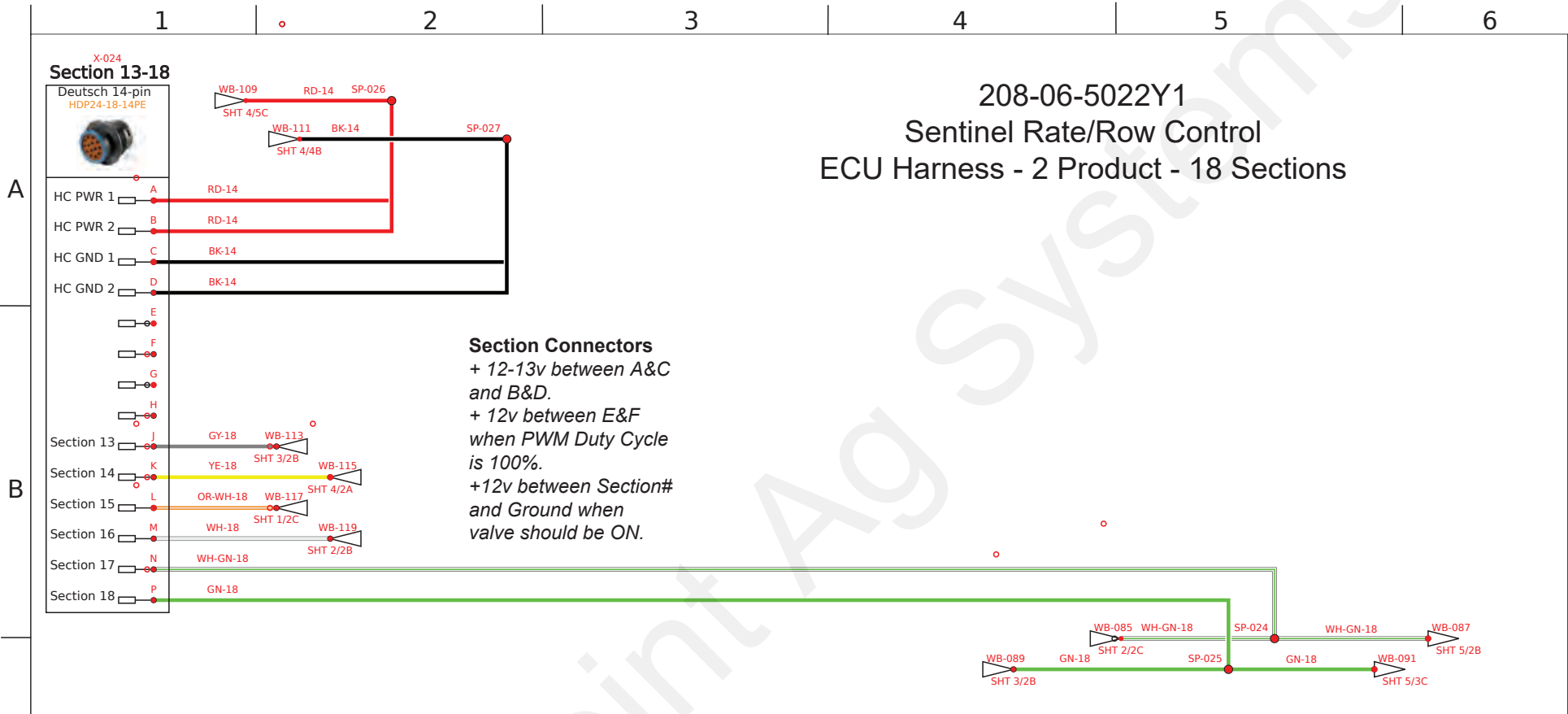

X-024
Section 13-18



- HC PWR 1 A
- HC PWR 2 B
- HC GND 1 C
- HC GND 2 D
- E
- F
- G
- H
- Section 13 J
- Section 14 K
- Section 15 L
- Section 16 M
- Section 17 N
- Section 18 P

Section Connectors
 + 12-13v between A&C
 and B&D.
 + 12v between E&F
 when PWM Duty Cycle
 is 100%.
 +12v between Section#
 and Ground when
 valve should be ON.

208-06-5022Y1 Connector pinouts for Rate Control and Row Control

ISO Connector - 12-pin

Ampseal 16 (Male) 12 Pin, Part# 776438-1		
BLK 14 AWG	1	ECU GND
RED 14 AWG	2	ECU Power
BLK	3	GND
YEL	4	ISO CAN Hi
	5	
BLU	6	Master Switch
	7	
RED 14 AWG	8	12 V Batt Power
RED	9	
GRN	10	ISO CAN Lo
	11	
	12	

Flowmeter Bus 1 & 2

4 PIN Deutsch Tower DT06-4S		
BLK-14	1	GND
GN-18	2	CAN Low
YE-18	3	CAN High
RD-14	4	+12V DC

Speed Input 150 MP Tower 3-PIN		
BRN	A	SIG
RED	B	+12V
BLK	C	GND

Implement Switch WP TOWER 2-PIN		
BLU	A	SIG
BLK	B	GND

General Diagnostic Tips

+12

Product 1

12 pin Deutsch Female DT06-125A		
RED	1	+12V DC
BLK	2	GND
BLU	3	Flow Signal 1
PUR	4	Pressure 1
YEL	5	PWM 1 (+)
BLK	6	PWM 1 (-)
BLU/WHT	7	Fill Flowmeter 1
ORG	8	Pump RPM 1
ORG/WHT	9	
	10	
BLK	11	Section 1
BRN	12	Section 2

Product 2

12 pin Deutsch Female DT06-125A		
RED	1	+12V DC
BLK	2	GND
BLU/WHT	3	Flow Signal 2
PUR/WHT	4	Pressure 2
WHT/YEL	5	PWM 2 (+)
BLK	6	PWM 2 (-)
BLU	7	Fill Flowmeter 2
ORG/WHT	8	Pump RPM 2
ORG	9	
	10	
WHT/BLK	11	Section 7
WHT/BRN	12	Section 8

LS Controller Prod1

8 Pin Deutsch Male		
RED	1	+12VDC
BLK	2	GND
PRP	3	Pressure 1
YEL	4	PWM+
BLK	5	PWM-
WHT/BLU	6	Valve A
PNK	7	Valve B

SECTIONS 1-6

14 pin Deutsch HDP24-18-14PE		
RED 14 AWG	A	HC PWR 1
RED 14 AWG	B	HC PWR 2
BLK 14 AWG	C	HC GND 1
BLK 14 AWG	D	HC GND 2
YEL	E	PWM +
BLK	F	PWM -
PUR	G	Pressure 1
WHT/GRN	H	Flow Return Valve
BLK	J	Sect 1
BRN	K	Sect 2
BLU	L	Sect 3
BLK/WHT	M	Sect 4
BRN/WHT	N	Sect 5
BLU/WHT	P	Sect 6

SECTIONS 7-12

HC PWR 1	A	RED 14 AWG
HC PWR 2	B	RED 14 AWG
HC GND 1	C	BLK 14 AWG
HC GND 2	D	BLK 14 AWG
PWM +	E	WHT/YEL
PWM -	F	BLK
Pressure 1	G	PUR/WHT
Flow Return Valve	H	GRN
Sect 7	J	WHT/BLK
Sect 8	K	WHT/BRN
Sect 9	L	WHT/BLU
Sect 10	M	PNK
Sect 11	N	WHT/YEL
Sect 12	P	GRN

SECTIONS 13-18

14 pin Deutsch HDP24-18-14PE		
RED 14 AWG	A	HC PWR 1
RED 14 AWG	B	HC PWR 2
BLK 14 AWG	C	HC GND 1
BLK 14 AWG	D	HC GND 2
	E	Empty
	F	Empty
	G	Empty
	H	Empty
Gray	J	Sect 13
YEL	K	Sect 14
OR-WHT	L	Sect 15
WHT	M	Sect 16
WHT/GRN	N	Sect 17
GRN	P	Sect 18

4-Pin Deutsch CAN Trunklines to 4-Pin AMP SuperSeal to connect Sentinel Flowmeter Modules

Part #	Number of flowmeter connectors	Length
208-06-2908Y2	1	5'
208-06-2909Y2	1	15'
208-06-4975Y1	2	5'
208-06-2910Y2	2	15'
208-06-2911Y2	3	15'
208-06-4976Y1	4	5'
208-06-4977Y1	4	15'

CAN Device
 + 12v between 2&1.
 1.5 to 2.5 v between 3&1.
 +2.5 to 3.5v between 4&1.

2908 and 2909 with one Device connector

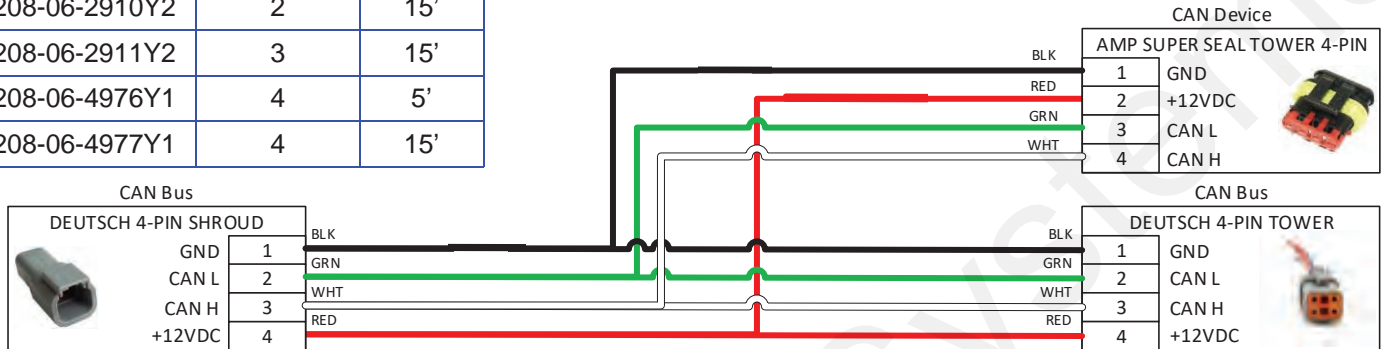

4975 and 2910 with two Device connectors

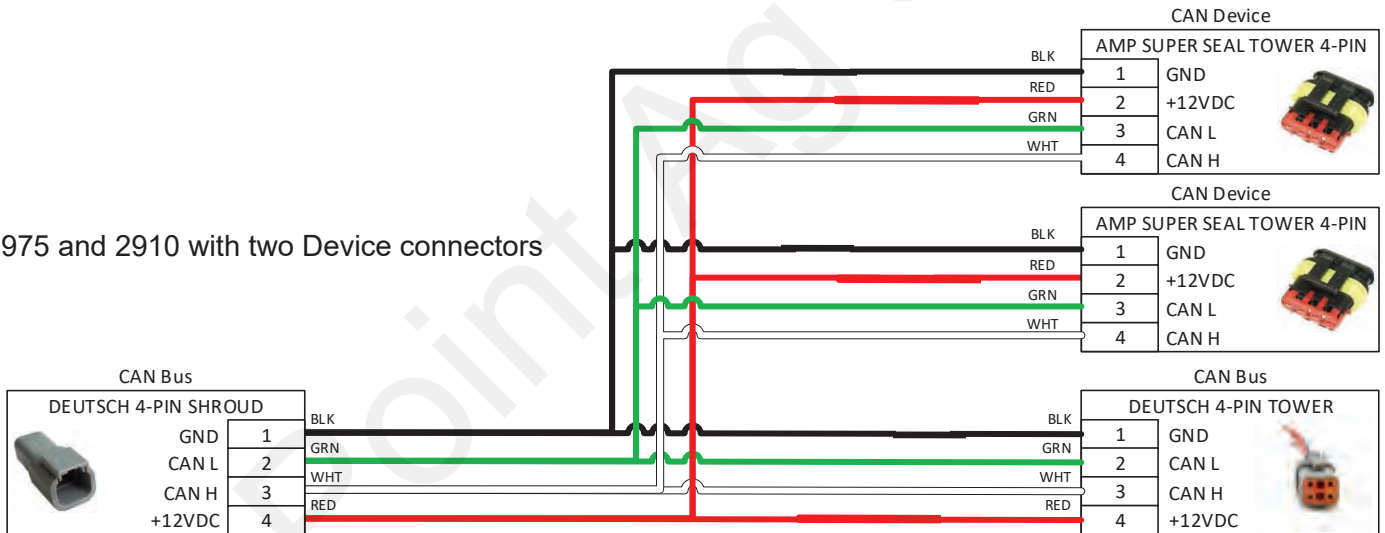

CAN Bus
 + 12v between 4&1.
 +2.5 to 3.5v between 3&1.
 +1.5 to 2.5v between 2&1.

2911 is similar to the above, but with three Device connectors.

4976 and 4977 are similar to the above, but with four Device connectors.

The Deutsch 4-pin Tower CAN Bus connector (bottom right of each drawing above) is plugged into another trunkline or, if it is the last trunkline, it is plugged into a Terminator.

214-00-3553Y1 Thru 214-00-3557Y1

Front Extension Harness – (9-Pin ISO Connector w/ 3-Pin Master Switch & 12-Pin ISO and 2-Pin Molex Power)

Wire 18AWG unless otherwise specified

+ Use this for troubleshooting harnessing, voltage, or communication issues. Some issues may need to be traced back to the 9-pin ISO connector on the back of the tractor and the battery.

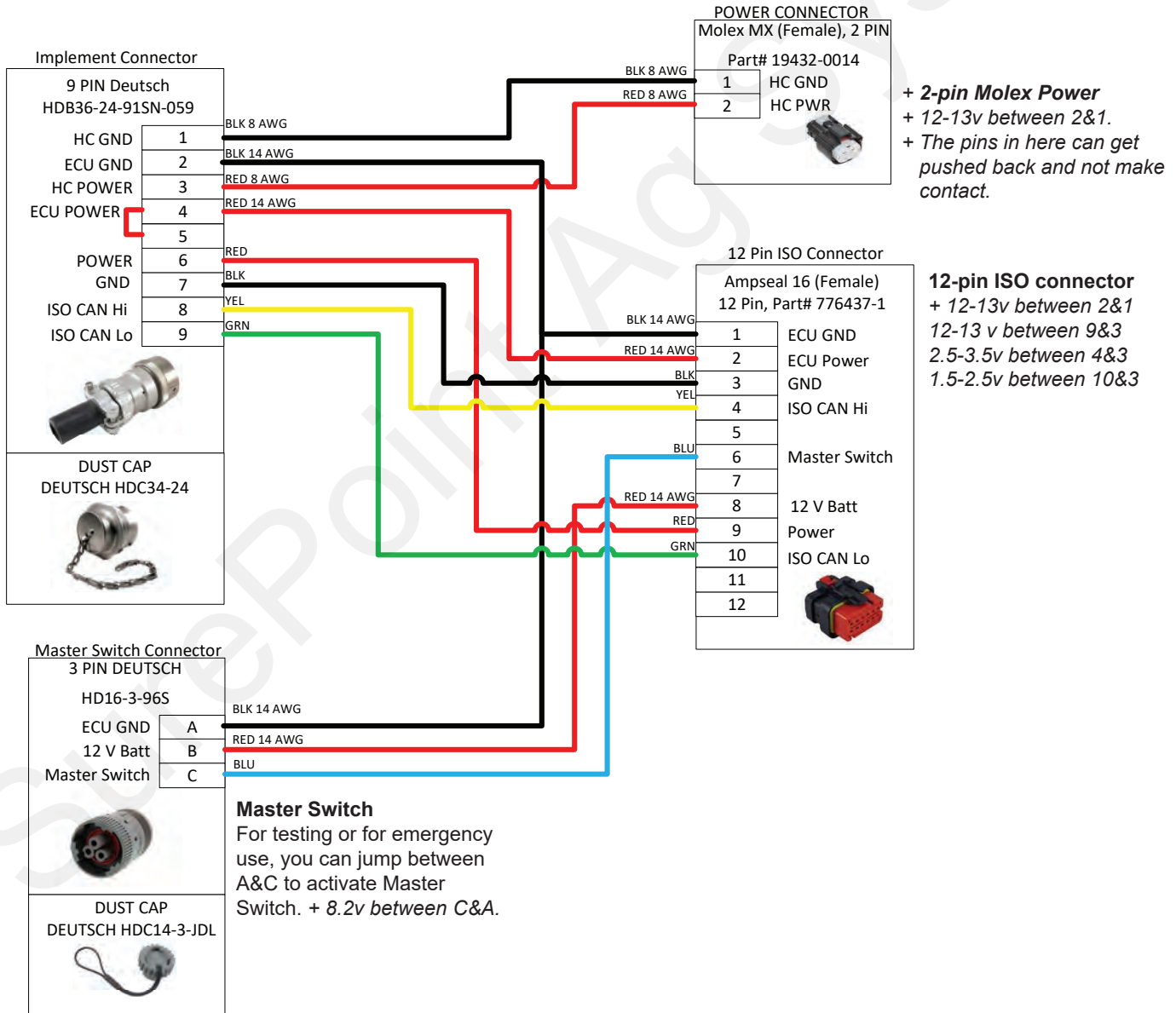

PumpRight Pump Installation

Mounting

1. Mount pump in your preferred location. The PumpRight pump has excellent suction and priming ability, so it can be mounted away from or above fertilizer tanks.
2. SurePoint has U-Bolts available to mount the pump directly to multiple bar sizes shown below. Each U-bolt kit includes 1 bolt and 2 flange nuts.
3. If the U-Bolts will not work, order the universal backer plate kit, number 515-203000 which will clamp to any size tube from 4" - 8" wide.

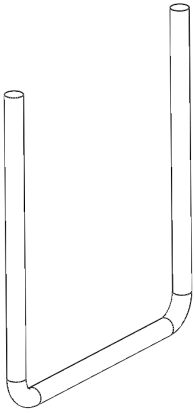

Mounting Bar Size	Item Number	Item Description
3" x 3"	380-1022	1/2" U-bolt Kit - 1/2", fits 3" x 3" tube - (3" opening)
4" x 4"	380-1023	1/2" U-bolt Kit - 1/2", fits 4" x 4" tube - (4" opening)
4" x 6"	380-1015	1/2" U-bolt Kit - 1/2", fits 4" x 6" tube - (4" opening)
4" x 7"	380-1039	1/2" U-bolt Kit - 1/2", fits 4" x 7" tube - (4" opening)
5" x 7"	380-1014	1/2" U-bolt Kit - 1/2", fits 5" x 7" tube - (5" opening)
6" x 4"	380-1017	1/2" U-bolt Kit - 1/2", fits 6" x 4" tube - (6" opening)
6" x 7"	380-1018	1/2" U-bolt Kit - 1/2", fits 7" x 6" tube - (7" opening)
7" x 5"	380-1016	1/2" U-bolt Kit - 1/2", fits 7" x 5" tube - (7" opening)
7" x 7"	380-1001	1/2" U-bolt Kit - 1/2", fits 7" x 7" tube - (7" opening)
6" x 10"	380-1021	1/2" U-bolt Kit - 1/2", fits 6" x 10" tube - (6" opening)
8" x 12"	380-1019	1/2" U-bolt Kit - 1/2", fits 8" x 12" tube - (8" opening)
8" x 16"	380-1020	1/2" U-bolt Kit - 1/2", fits 8" x 16" tube - (8" opening)



PumpRight Hydraulic Connections

PWM Valve

Manual Override - Push down and turn 1/2 turn CCW to lift the valve for manual override to check for proper hydraulic operation. **Override will completely open valve, so limit tractor hydraulic flow to valve.**

(May need to clean packed dirt to allow movement of override knob.)

Push down and turn 1/2 turn CW to return to operating position.

PWM Valve Connector -2 Pin MP Shroud

*Troubleshooting Tip:
To check coil, an ohmmeter placed on the two pins should show 7-9 ohms.*

Pressure line from Tractor

Load Sense Port—For power beyond hydraulic use only.

Bypass Valve—Remove the cap to access a bypass needle valve. This valve is shipped from the factory closed. **The only case when valve should be open is when running in series with other hydraulic motors.**

Depending on your tractor and exact hydraulic plumbing scenario your pump may turn very slowly when it should stop. To stop the pump completely, open the bypass valve slightly.

To adjust the Bypass Needle Valve, first loosen the lock nut. Do not overtighten the needle valve.

Return oil to Tank - Check valve included on return port

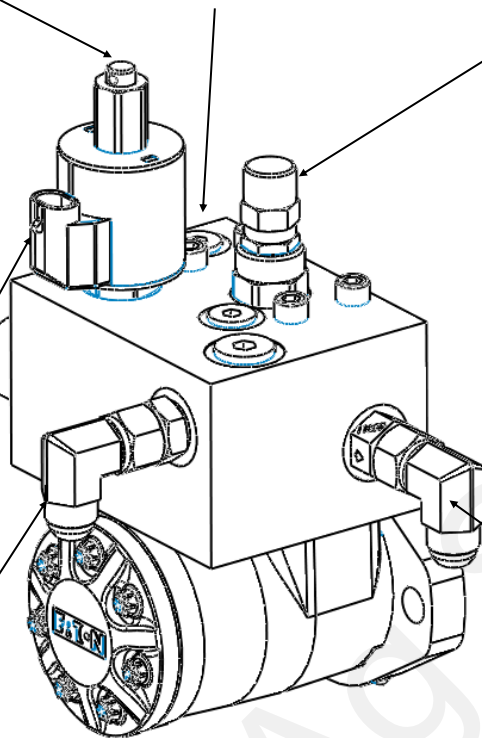

	⚠ DANGER	Hydraulic oil under extremely high pressure. Do not use hand or any other skin to check for or to stop hydraulic leaks. Be sure pressure is relieved before loosening hydraulic fittings. Replace worn hoses immediately. Seek medical care immediately if hydraulic oil is shot into the eye or the skin.
---	-----------------	---

Pump Rotation Check Valve

A check valve is included on the outlet port of the hydraulic valve. This prevents the pump from running in the wrong direction. If ran in the wrong direction, liquid will be pumped, however the hydraulic valve will not be able to control the flow. The check valve can be identified by the Part Number 1108R stamped on it and a flow direction arrow.

How it Works with Power Beyond Hydraulics

This valve is designed to work with power beyond hydraulics. This configuration will not require a standard tractor remote hydraulic valve. The load sense port and hose described next will typically not be needed if other hydraulic ports are in use. If the load sense is needed, do this: First, remove the load sense plug and install a #6 male boss x #6 JIC adapter fitting, SurePoint PN 161-01-6MB-6MJ. Then run a 3/8" or 1/4" hydraulic hose back to the tractor. This hose will connect to the load sense port on the tractor. The load sense line will signal the tractor hydraulic system to supply the flow needed by the pump to meet your application rate. The SurePoint valve has an internal load sense check valve, which is required for power beyond hydraulics. The bypass valve (see above) must be closed to use power beyond hydraulics or else an unlimited amount of oil will be continuously circulated.

PumpRight Hydraulic Connections

Hydraulic Hose

SurePoint recommends 1/2" hydraulic hose for both pump inlet and outlet. The hoses will need #8 JIC female swivel fittings.

Where do I get hydraulic flow for my PumpRight?

This question is often asked as many implements use up all the hydraulic connections on a tractor. SurePoint has some recommendations as to what works best.

connections on a tractor.
Preferred

Best Option - Dedicated PumpRight Circuit

If you have a tractor remote available, attach the tractor remote valve directly to the PumpRight pressure and return ports. **DO NOT** try to avoid this method simply to save another set of hydraulic hoses running to the tractor. Operating the PumpRight on it's own circuit is the simplest for installation and operation. It guarantees the PumpRight won't negatively affect any other hydraulic components on your equipment.

Alternate Option - In SERIES with John Deere CCS Fan or Bulk Fill Seed Fan

If you do not have a tractor remote valve available, this may be your best method. You can plumb the PumpRight after the seed distribution fan. **If using this method, the SurePoint PWM bypass valve must be open** (see previous page for instruction & picture). If bypass is left closed, the SurePoint valve will limit the speed of the seed distribution fan.

For example, the John Deere CCS fan of oil. This will limit the PumpRight GPM oil necessary for maximum flow). See the charts on the next page for adjusted maximum pump flow. See section G for flow charts to determine your necessary flow rate. If you absolutely need the maximum flow in this case, SurePoint has an alternate motor (smaller displacement) to increase pump speed at 7 GPM oil flow.

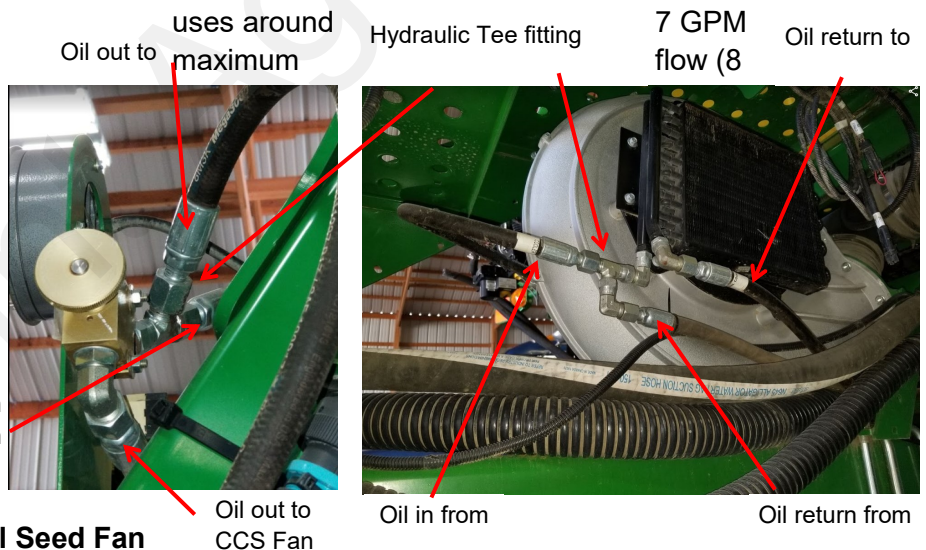

Alternate Option - In PARALLEL with John Deere CCS Fan or Bulk Fill Seed Fan (Shown Right)

DO NOT plumb the PumpRight in series with a vacuum fan.

The vacuum fan uses just a few GPM of oil. Also, problems will be caused by excessive pressure at the vacuum fan motor

⚠ DANGER	<i>Hydraulic oil under extremely high pressure. Do not use hand or any other skin to check for or to stop hydraulic leaks. Be sure pressure is relieved before loosening hydraulic fittings. Replace worn hoses immediately. Seek medical care immediately if hydraulic oil is shot into the eye or the skin.</i>
-----------------	---

PumpRight Hydraulic Oil Flow Requirements

*(Requirements for 4.0 CID Motor—standard SurePoint motor beginning in 2016—
Earlier motor was 4.9 CID which uses 20% more oil)*

Setting Tractor Hydraulic Remote Speed

PumpRight pumps require a constant hydraulic oil flow from the tractor. The amount of oil needed varies with pump size and speed. The chart at right shows the necessary oil flow for each pump model at varying fertilizer flows.

Use this procedure to determine the correct setting on your tractor hydraulic flow.

1. Run the fertilizer system in the field at the maximum rate and ground speed.
2. Turn down the hydraulic flow slowly while watching the pump flow (Volume / Minute).
3. Observe when the Volume / Minute begins to drop.
4. Turn the hydraulic flow back up slightly.

This setting will provide the Pump Right pump just enough oil for your application rate.

If running with the bypass open (only recommended when 2 motors are operated in series) this process will minimize the oil circulated in the bypass loop, leaving more oil flow for other hydraulic functions.



The pump is rated at a maximum of 550 RPM. Spinning the pump over 550 RPM may cause pump failure.

The system will spin the pump faster than that if precautions are not taken to limit the speed. This could happen if the strainer becomes plugged or blocked and the controller attempts to speed the pump up to achieve the desired Rate.

It could also happen if a high pressure situation occurs that opens the Pressure Relief Valve (PRV) and the pump speeds up to try to achieve the Rate.

A way to limit the maximum pump speed is to set the High PWM Limit just above what is needed for regular operation. If the pump tries to speed up above that, check for blocked strainer or other issue.

Model PR17 - 3 Diaphragms		
Fertilizer Flow (GPM)	Pump Speed (RPM)	Hydraulic Oil Flow (GPM)
5	137	2.4
10	275	4.8
15	412	7.1
17	467	8.1
Model PR30 - 3 Diaphragms		
Fertilizer Flow (GPM)	Pump Speed (RPM)	Hydraulic Oil Flow (GPM)
5	85	1.5
10	170	2.9
15	255	4.4
20	340	5.9
25	425	7.4
30	510	8.8
Model PR40 - 4 Diaphragms		
Fertilizer Flow (GPM)	Pump Speed (RPM)	Hydraulic Oil Flow (GPM)
10	115	2.0
20	229	4.0
30	344	6.0
40	458	7.9
Model D250 - 6 Diaphragms		
Fertilizer Flow (GPM)	Pump Speed (RPM)	Hydraulic Oil Flow (GPM)
10	86	1.6
20	172	3.2
30	258	4.8
40	343	6.4
50	429	8.0
55	472	8.6
Model PR80 - 4 Diaphragms		
Fertilizer Flow (GPM)	Pump Speed (RPM)	Hydraulic Oil Flow (GPM)
10	57	1.0
20	114	2.0
30	170	2.9
40	227	3.9
50	284	4.9
60	340	5.9
70	397	6.9
80	454	7.9



PR17 & PR30 Liquid Plumbing Connections

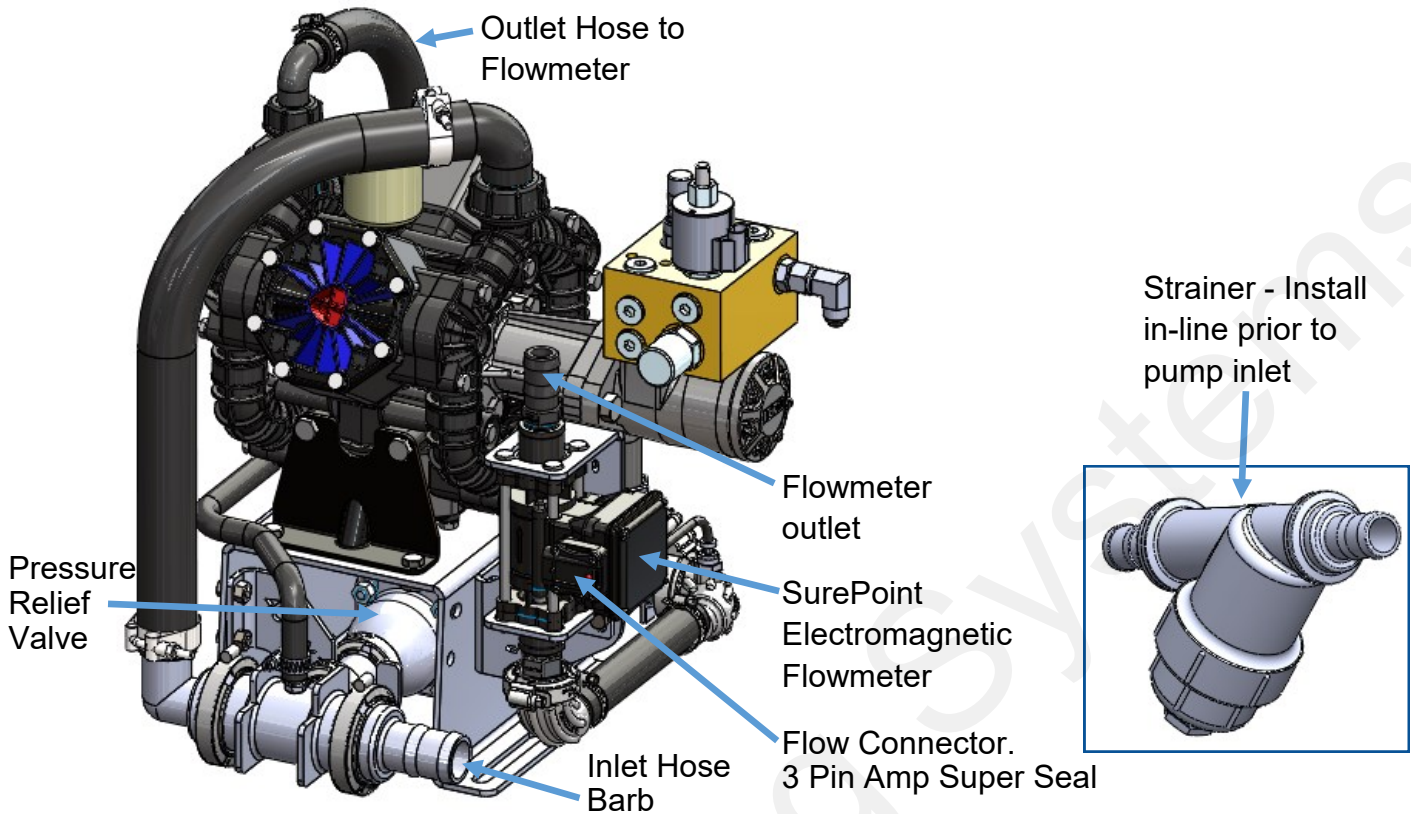



Inlet: The PR17 and PR30 PumpRight are shipped with a 1 1/2" inlet hose barb. Attach this to the hose from your supply tank and strainer. A 1 1/2" 90 degree hose barb is included and can be substituted.

Inlet Strainer: A 20 mesh strainer is included in the pump kit. The manifold strainer includes two hose bars so it can be mounted anywhere in the inlet line. If space allows, the strainer can be mounted directly to the inlet plumbing assembly as shown below.

Outlet: The outlet is plumbed directly to the flowmeter with 1" hose. As shown above, the flowmeter may be mounted directly to the PumpRight pump. The flowmeter outlet is a 1" hose barb. The outlet hose should be a minimum of 24" long with a gentle curve prior to any fittings for optimum flowmeter performance. The flowmeter outlet will attach to your manifold(s) or section valves. A 3/4" hose barb is included in the bag of parts and can be substituted on the flowmeter outlet.

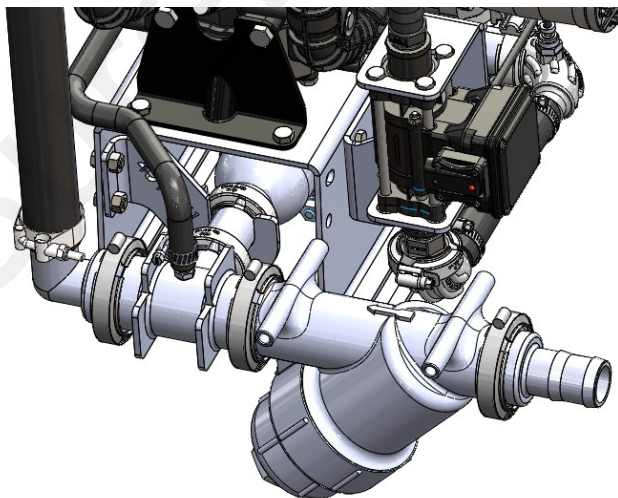
Pressure Relief Valve (PRV): The PRV is a 100 psi relief. If there is a restriction that creates over 100 psi in the system, the PRV will open allowing the excess flow to pass back to the inlet side of the pump. This protects the pump and fertilizer system from damage.





 **CAUTION**

These pumps can deliver liquid at high pressure (290 PSI). Be sure the 100 PSI Pressure Relief Valve (PRV) is installed and functioning so system pressure will be kept under 100 PSI. Check hoses, hose clamps, and liquid fittings regularly and repair or replace loose connections.

PR40 & D250 Liquid Plumbing Connections

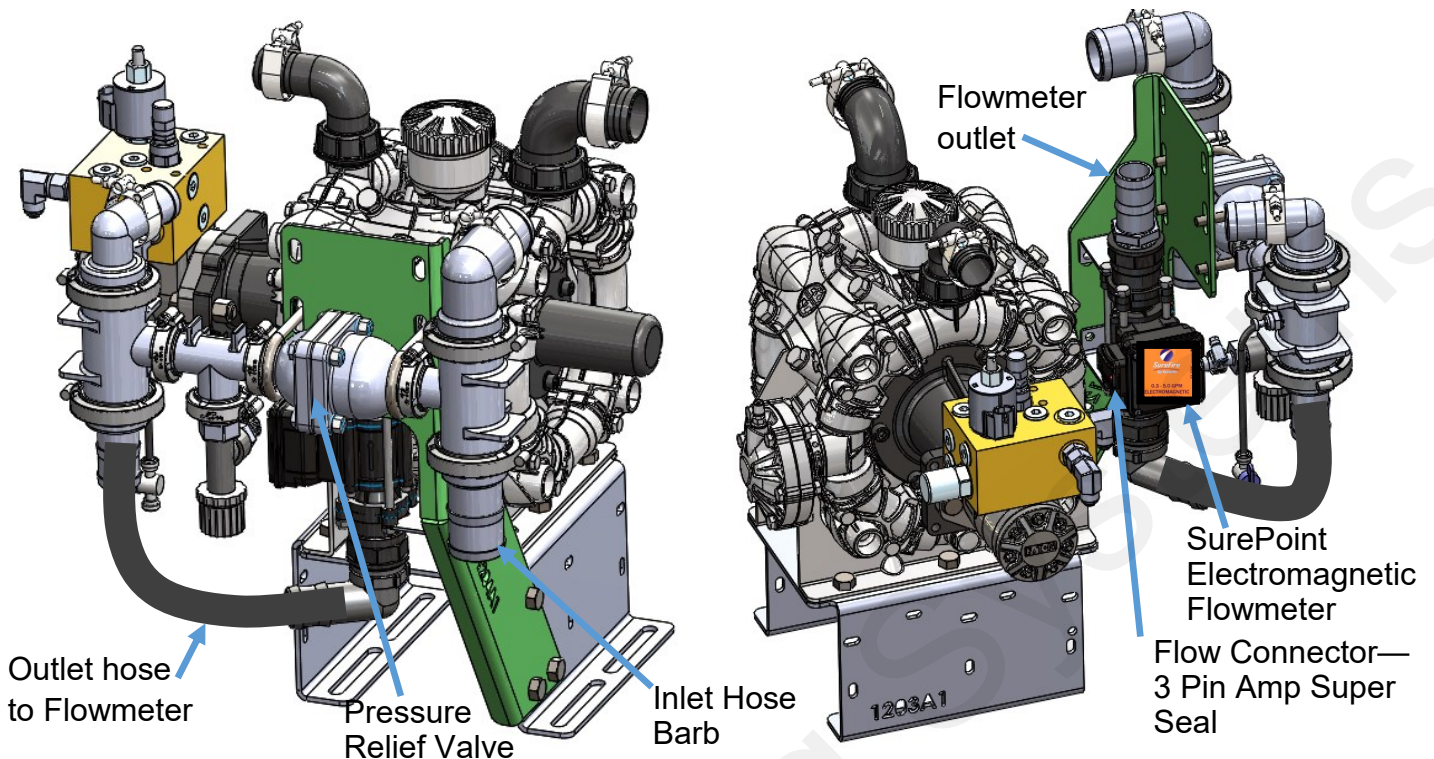

Inlet: The PR40 and D250 PumpRight are shipped with a 2" inlet hose barb. Attach this to the hose from your supply tank and strainer. A 2" 90 degree hose barb is included and can be substituted.

Inlet Strainer: A 20 mesh strainer is included in the pump kit. The manifold strainer includes two hose barbs so it can be mounted anywhere in the inlet line. If space allows, the strainer can be mounted directly to the inlet plumbing assembly as shown in image to the left.

Outlet: The outlet is plumbed directly to the flowmeter with 1 1/2" hose. As shown above, the flowmeter may be mounted directly to the PumpRight pump. The flowmeter outlet is a 1 1/2" hose barb. The outlet hose should be a minimum of 24" long with a gentle curve prior to any fittings for optimum flowmeter performance. The flowmeter outlet will attach to your manifold(s) or section valves.

Pressure Relief Valve (PRV): The PRV is a 100 psi relief. If there is a restriction that creates over 100 psi in the system, the PRV will open allowing the excess flow to pass back to the inlet side of the pump. This protects the pump and fertilizer system from damage.



These pumps can deliver liquid at high pressure (290 PSI). Be sure the 100 PSI Pressure Relief Valve (PRV) is installed and functioning so system pressure will be kept under 100 PSI. Check hoses, hose clamps, and liquid fittings regularly and repair or replace loose connections.

How to get to Sentinel on the VT (or UT)

John Deere 2630 Display

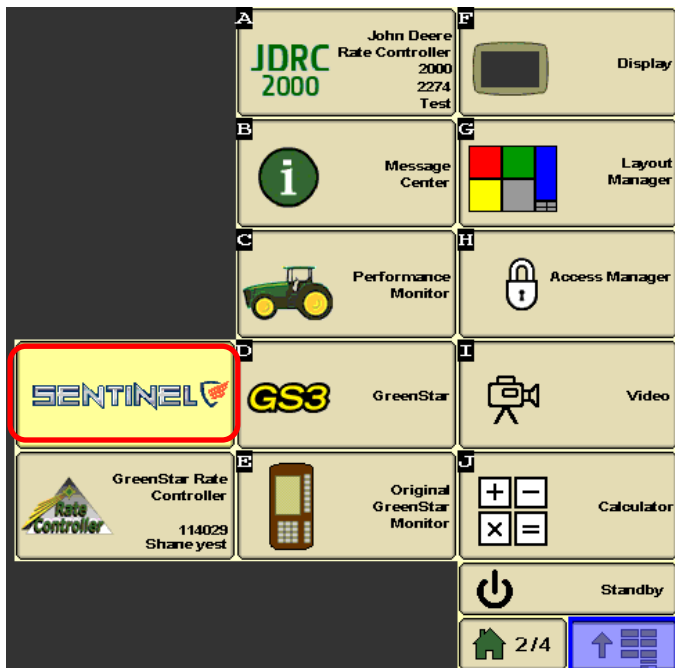

Pro 700 Display

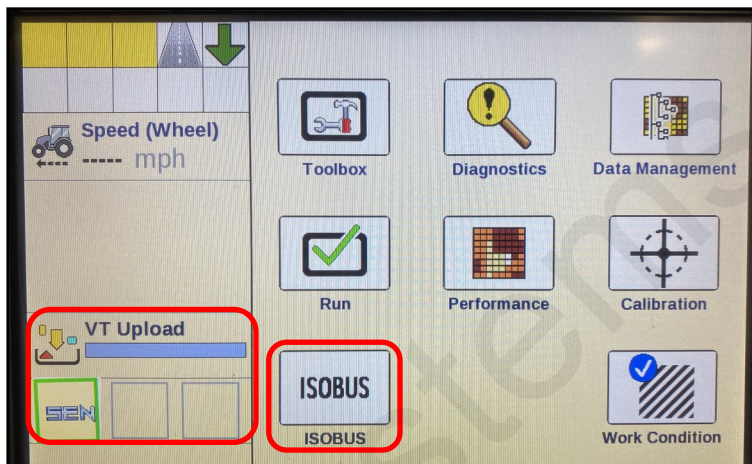

You can set up VT Upload and VT Implements on Toolbox > Layout (shown in Left Area above). On first bootup, VT Upload may take several minutes for a new device.

Press ISOBUS to go to ISOBUS devices or Press the Sentinel icon to go to the Sentinel screens.

John Deere 4640 Gen 4 Display



PRESS "ISO" to go to the ISOBUS VT screens. There may be more than one ISOBUS device connected.

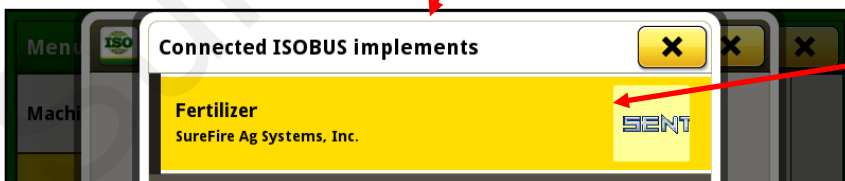
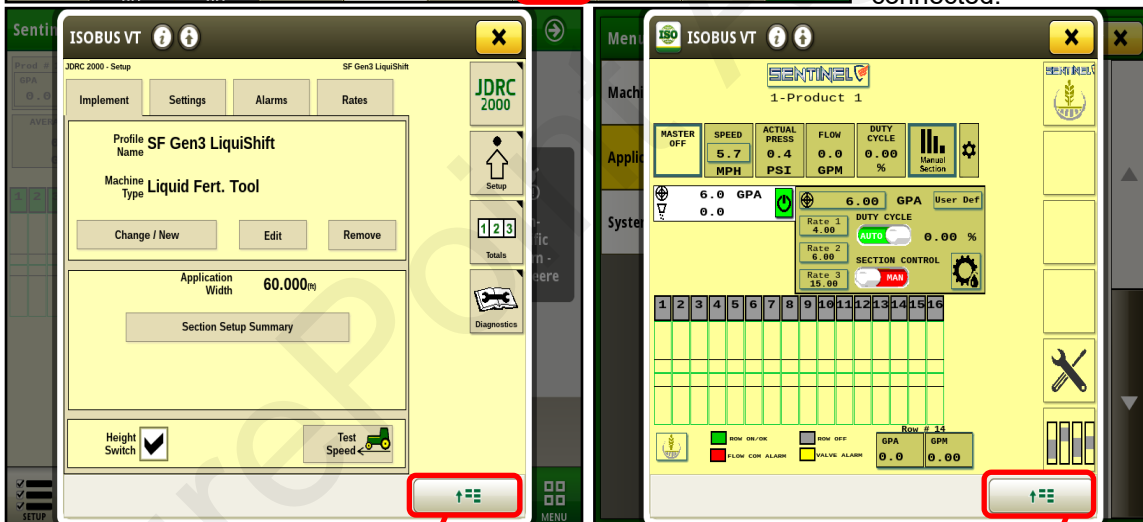

ISOBUS VT Menu

There may be more than one ISOBUS device connected.

How to get to Sentinel on the VT (or UT)

Ag Leader InCommand



Trimble TMX-2050

Icons from Sentinel

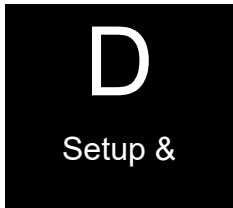

Sentinel Wheat “HOME” button - returns to the main run screen.



IMPLEMENT Setup - enter implement geometry



SPEED Setup - select speed source and see which speed sources are reporting speed.



HARDWARE - set up height switch, master switch, task control, Intellisec-tion



RATE Setup - set up rate mode, target rate, rate smoothing



SETTINGS tools - set up products, devices, rows, sections

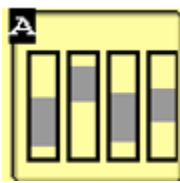

ROW BAR - see Sentinel row graphs depicting the flow on each row

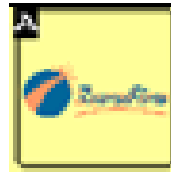

SurePoint - see software version. Go to Auxiliary Settings screen.

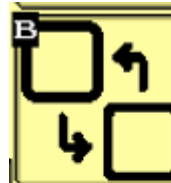

Next VT - when more than one display is in use, this moves the Sentinel to the next screen. (v.1.3.0)



Save to this VT - when more than one display is available. (v.1.3.0)



Nozzle Test - Run a test with a simulated speed and target rate. (v.1.3.0)



Catch Test - check and adjust flow-meter calibration. (v.1.3.0)



Save Task Controller settings



LiquiShift - this icon will be available when Sentinel is controlling the LiquiShift valves.

Setting Up a System With Sentinel Row Control and Sentinel Row Flow Monitoring



226-01-3547Y1
Sentinel ISOBUS ECU

Typically will use one of the following Sentinel ECU Harnesses

For Row Control







208-06-5022Y1	Sentinel Row Control and Flow Monitoring ECU Harness - 2 products - 18 sections
208-06-4099Y4	Sentinel Row Control and Flow Monitoring ECU Harness - 2 products - 18 sections
208-06-4984Y2	Sentinel Row Control and Flow Monitoring ECU Harness - 4 products - 18 sections
208-06-4504Y1	Sentinel Row Control Valve

Sentinel Setup and Configuration

Set-up and Configuration for Row Control & Row Monitoring

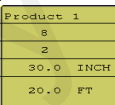
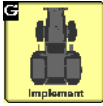
The following pages will guide you through the initial set-up and configuration of your Sentinel Row Control & Row Monitoring system. Below is an overview of the steps necessary to fully configure the system before operation. Each subsequent page outlines the page features as well as the sequence of buttons used to navigate to that page from the HOME screen. Your setup screens may vary.

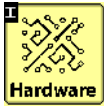

Basic Steps for Initial System Set-up for Row Control & Row Monitoring

REFERENCE	STEP	
Page #		
36	1. Press the HOME button	
36	2. Go to the settings page by touching the SETTINGS button	
36	3. On the settings page, specify the number of products being monitored (maximum of 4)	
36-37	4. Configure each product by touching the PRODUCT button	
36	5. Select DEVICE (<i>Liquid Rate Control + Monitor</i>) and set up each product (sections, rows,...)	
37	6. Press MORE , set up Rate (USER DEF), Smoothing (10%), other options for this setup.	
	7. When finished, use the BACK arrow to go back to the SETTINGS menu.	
38	8. Set up the implement dimensions by touching the IMPLEMENT button.	
38	9. Choose a speed source by selecting the SPEED button.	
38	10. Select system control options (task control, lift switch, etc.) under HARDWARE .	
39(37)	11. Select the Rate Mode (<i>USER DEF</i>) at RATE SETUP .	
39	12. From the Settings screen, touch the NEXT arrow.	
40	13. Click on Flow Module Diagnostics .	
	14. Ensure that all flow modules are plugged in and click Reset All Addresses	
	15. Unplug all of the Sentinel Flowmeter Modules.	
	16. Beginning with flowmeter module #1 (on Product 1), plug it back in - module 1 should turn green on the screen. Have someone watch the screen to verify successful addressing for each module.	
	17. Moving across the implement, plug in each flowmeter module for Product 1 in order.	
40	18. Select the correct module orientation (ABCD or DCBA) (What is Row 1? (A) or (D)?)	
	19. Click on Valve Module Diagnostics. Reset all addresses .	
	20. Then, unplug all and plug in the Valve Control Interface Modules in the same manner.	
	21. Be sure the valve module orientation matches the flow module orientation (ABCD or DCBA).	

Sentinel Setup and Configuration

The following pages will guide you through the initial set-up and configuration of your Sentinel Row Control & Row Monitoring system. Below is an overview of the steps necessary to fully configure the system before operation. Each subsequent page outlines the page features as well as the sequence of buttons used to navigate to that page from the HOME screen. Your screens may vary.

Basic Steps for Initial System Set-up for Row Control & Row Monitoring

REFERENCE PAGE	STEP
\	22. If applicable, address the modules for product 2 by repeating the above steps for product 2.
41	23. Customizing Scans and Alarms
42	24. Setup settings for Rate Control - Control Speed, Flow Cal, PWM Max and Min
43	25. Valve Setup and Row Detail Screen
44	26. Software Version and Auxiliary Settings Screens 
45	27. Customizable Toolbar and Totalizer Counters
46-48	28. Row Control & Row Monitoring Run Screen and Operation & Setup Summary
49	29. Nozzle Test - Test with Simulated Speed and Rate 

SETUP for Row Control & Row Flow Monitoring - Settings - Product - Device

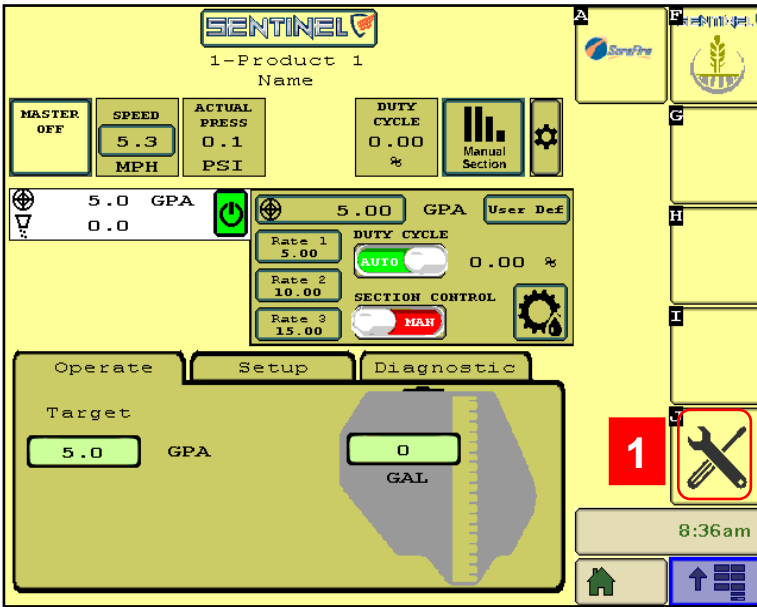

1.) Press the **SETTINGS** Tools button to go to the System Configuration screens.

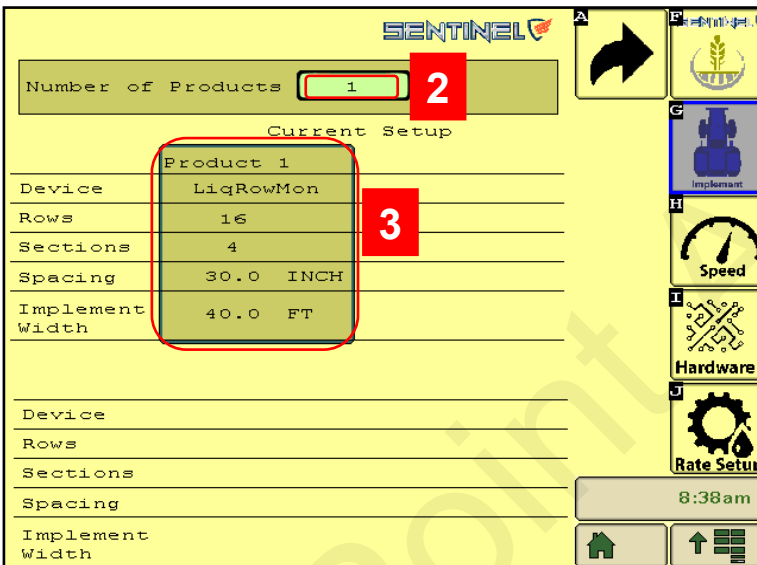

2.) Enter the **number of products** that will be monitored or controlled with the Sentinel.

3.) Press the big **Product 1** box.

(If the system has two products, there will be a Product 2 box to the right of Product 1. Set up Product 2 in a similar fashion to what is shown for Product 1.)

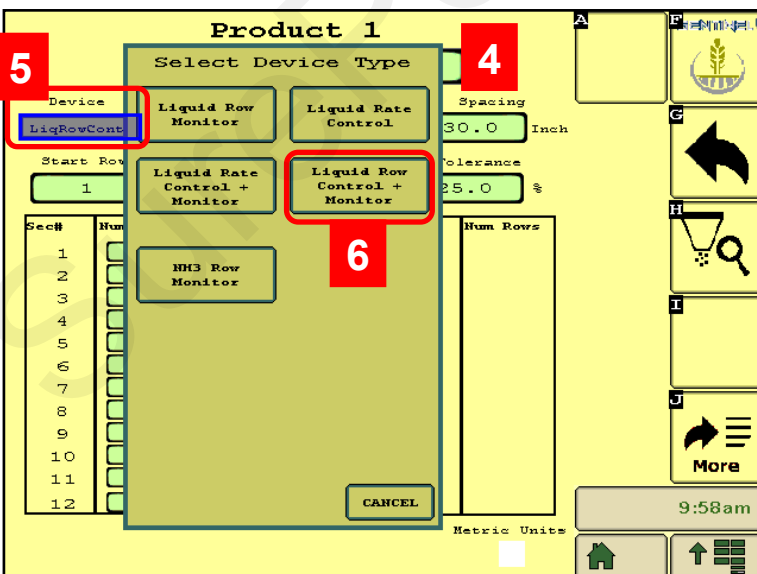

4.) Enter a name for the Product.

5.) Press the box under **"Device"**.

6.) Select **"Liquid Row Control + Monitor"** for Row Control and to use the Sentinel flowmeter modules for row flow monitoring. (If Liquid Row Control + Monitor is not an option, call SurePoint to get an unlock code (no charge).)

SETUP for Row Control & Row Flow Monitoring

7.) Enter the number of **SECTIONS** (same as number of rows) for this product.

8.) Enter the number of **ROWS** for this product.

9.) Enter the row spacing in **INCHES**.

10.) **Start Row** = 1 for Product 1.

Product 2 Start Row will typically be 1 more than the number of Rows on Product 1. On a 16-row system, Product 2 will start with Row 17.

11.) Enter **Implement Width** in FT.

12.) **Tolerance** - start at 25%. You can lower this in the field. If the tolerance is too low, there will be unnecessary alarms. The Row Bar Graph will show red if a row is off-rate by the Tolerance % or more.

13.) Should be 1 row in each section.

14a.) Check this box for **Metric Units**.

14b.) Press **More** to go to the next screen.

15.) See at left.

15.) See below: **Rate Mode** - For row control, set this to **Rx** (for prescriptions) or to **User Def** to enter preset rates. Enter the main target rate in **Rate**.

16.) **Smoothing** - Start with 10%. Typical setting will be from 5 to 15%. If the actual rate at any time is within this % of the Target Rate, the display will show the Actual Rate as being equal to the Target Rate.

The green line on the Row Bar Graph will not widen if the row variation is less than the Row Smooth %

17.) You can enter up to 3 user-defined rates. These can also be entered on the Rate Setup screen.

18.) **Outside Row Rates** is typically "X 1.0".

Some applications may be "X 0.5" (half-rate) or "X 1.5" (rate and a half) for outside rows.

19.) **Control Integral (Ki)** - Tech Support use

20.) **Interplant Mode** -

21.) **Module Orientation** - **ABCD** if Row 1 is A. **DCBA** if Row 1 is D on the Sentinel flowmeter module.

22.) Press the **Back Arrow** when finished with this screen.

SETUP for Row Control & Row Flow Monitoring

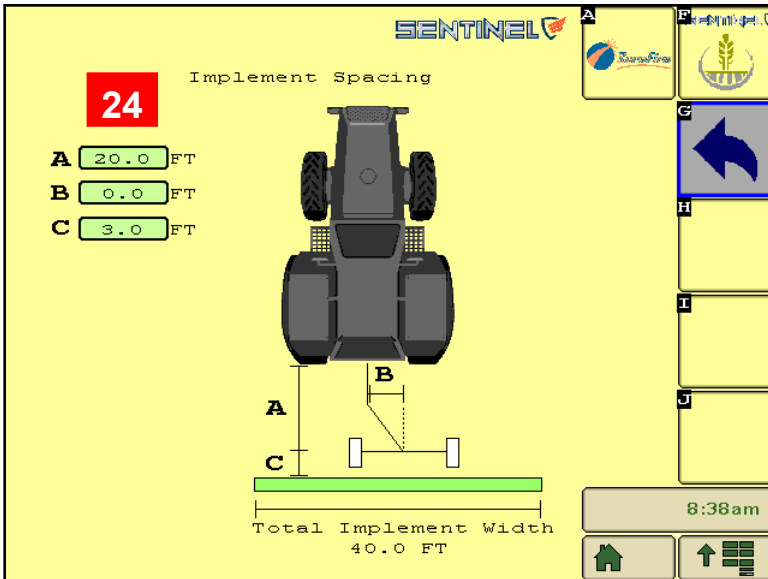

24.) Press **Implement** to enter and verify the Implement geometry.

The Implement dimensions are used when Task Control is enabled.

A = distance from GPS Antenna to Hitch
 B = implement offset
 C = distance from hitch to application point

Press the Back Arrow when finished.



25.) On the right side, Press **Speed**.

Press the top box to select the Speed Source. This is typically Ground Speed.

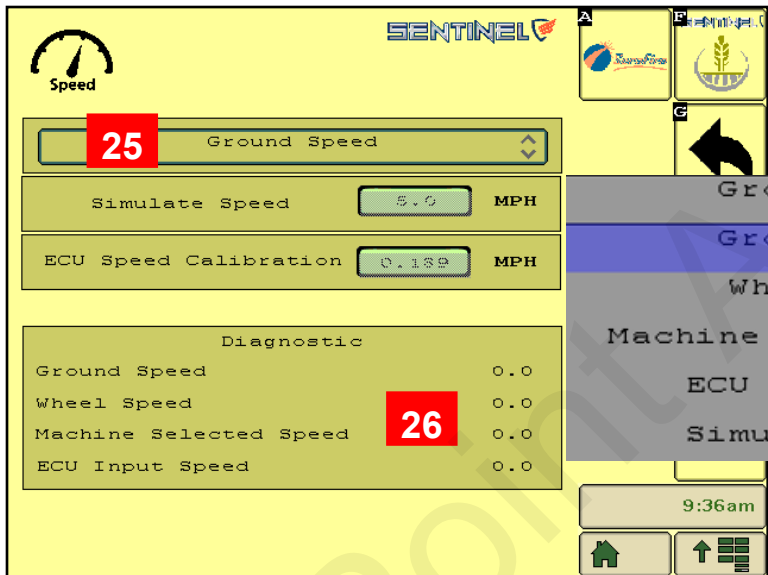

26.) Check this box while moving to see which speed sources are reporting.

27.) On the right side, press **Hardware**.

28.) **Use Master Switch** - check this box if a Master Switch (Foot Switch) is to be used by Sentinel.

29.) **Use Height Switch** - Check this if the Sentinel has a dedicated height switch.

30.) **Setup** : Choose switch or sensor.

31.) **Enable Task Control** - normally used for row control. Task Control must be activated on the display software.

32.) **Enable IntelliSection Technology** - normally not used in this setup.

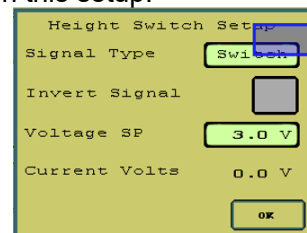
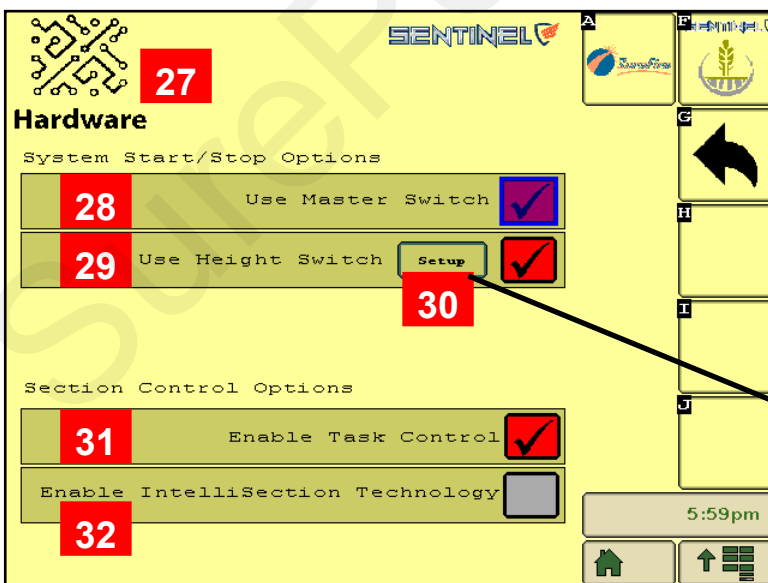

SETUP for Row Control & Row Flow Monitoring - Rate Setup - Flow Adjustment - 2 Products

Product 2
2-Product 2

33

Rate Mode: User Def Rate: 5.00 Rate Smooth: 10 %

Flow Adjustment: 1.00 Reset Totals... Row Smooth: 10 %

User Defined Manual Rates: 5.00 10.00 15.00

Outside Row Rates: First X 1.0 Last X 1.0

Control Integral (KI): 0.10

Interplant Mode: Disabled

34

11:22am

33.) For Row Control verify the Setting is Rx or User Def. Smoothing usually starts at 10%. Use Presets to enter up to 3 rates.



34.) **Flow Adjustment** - Use this to synchronize the Sentinel flowmeter modules with the main system flowmeter. Once the accuracy of the main flowmeter has been confirmed, change the Flow Adjustment factor as needed to synchronize the Sentinel reading with the main flowmeter reading.

$$\frac{\text{Main Flowmeter GPM}}{\text{Sentinel Total Flow GPM}} = \text{Flow Adjustment Factor}$$

(If different from 1.00, this should not be much different. Generally, will be between 0.95 and 1.05.)

V 1.3.0 has **Rate Smooth** for the overall target rate display. It also has **Row Smooth** to apply smoothing to the Row Bars showing the flow on each row. Normal ranges for both are 5% to 15%.

Rate Mode: User Def Rate: 5.00 Rate Smooth: 10 %

Flow Adjustment: 1.00 Reset Totals... Row Smooth: 10 %

SETUP for 2 products with Row Control and Row Flow Monitoring

Number of Products: 2

Current Setup		
	Product 1	Product 2
Device	LiqRowCont	LiqRowCont
Rows	16	16
Sections	2	16
Spacing	30.0 INCH	30.0 INCH
Implement Width	40.0 FT	40.0 FT

5:50pm

Product 2
2-Product 2

Device: LiqRowCont Sections: 16 Total Rows: 16 Spacing: 30.0 Inch

Start Row: 17 Implement Width: 40.0 FT Tolerance: 25.0 %

Sec#	Num Rows	Sec#	Num Rows	Sec#	Num Rows
1	1	13	1		
2	1	14	1		
3	1	15	1		
4	1	16	1		
5	1				
6	1				
7	1				
8	1				
9	1				
10	1				
11	1				
12	1				

Metric Units

5:51pm

If you are setting up Sentinel to do row control and row monitoring on 2 products your screen will look like this. You will need to go through the setup steps for both Product 1 and Product 2.

Product 2 will usually start with the next row after Product 1, so if Product 1 has 16 rows, Product 2 will start with Row 17.

Sentinel Setup and Configuration

Addressing Sentinel Flow Modules & Valve Control Module Interface



Flow Module & Valve Module Diagnostics

To address the Sentinel flow modules, start by having all the modules plugged in. From this screen, push **Reset All Addresses**. This sends a message to the modules to erase their address. All flow modules for Product 1 are then unplugged and then plugged back in, in order across the machine. As each module is plugged in, Sentinel identifies it's location on the machine and the module is then given its new address and it will turn green on the screen. *Have someone watch this screen to be sure each module is recognized as it is plugged in.*

Once all modules are addressed, choose the proper **orientation** as described below.

Repeat , starting with **Valve Module Diag**. **Reset All Addresses** -unplug and plug in valve control modules. Choose orientation to match flow modules.

Module Diagnostics Screen

Module Status					
1	2	3	4	5	
ABCD	ABCD	ABCD	ABCD		
11	12	13	14	15	
16	17	18	19	20	
21	22	23	24	25	
26	27	28	29	30	

Legend

- Expected but no Communication
- Expected and communicating
- Not expected

Reset All Addresses

8:53am

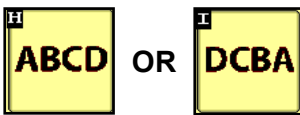

Most machines will have the modules mounted facing forward, causing Row 1 to correspond with row D on the module. Therefore, the orientation DCBA must be selected. Likewise, if the modules are mounted rear-facing, the orientation ABCD will be selected.



Press the toggle button to go to the next page of modules

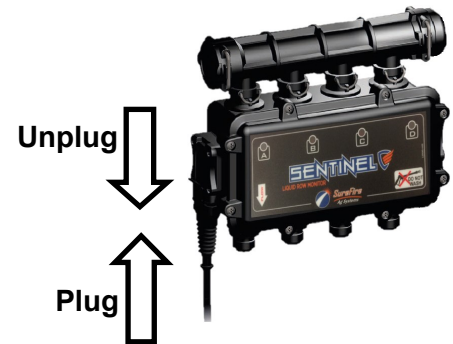

Example 16-Row—D C B A Orientation

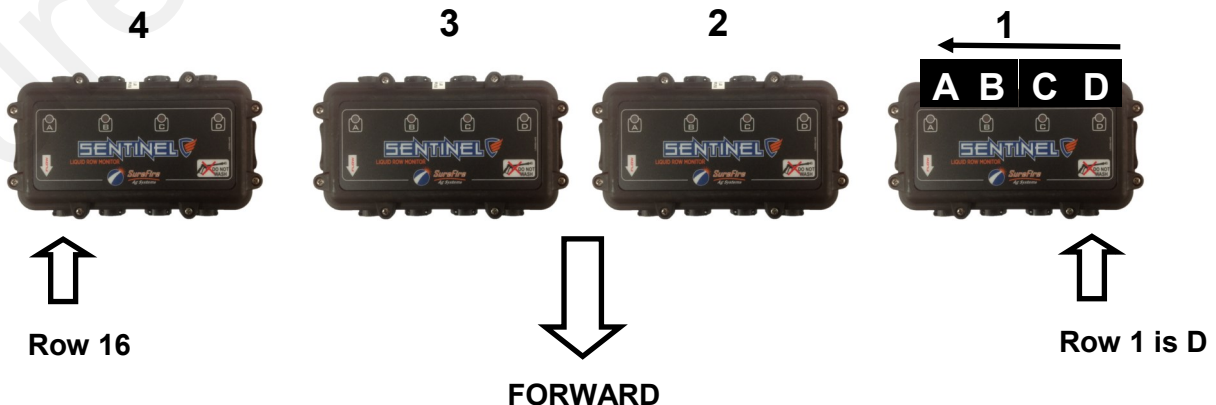

Customizing Scans & Alarms, etc



This screen allows the user to change how row information is displayed on the HOME screen.

- 35.) When checked, the **Auto Scan** feature will scan through the product pages and/or rows on the HOME screen. You can change the length of time it stays on each page or row before advancing.
- 36.) **Auto Hide Alarms (if checked)** sets how long full-page alarms are displayed before they go away (see pg. 20)
- 37.) **Disable Alarms** - Check this to turn off alarms. May want to do this for testing or troubleshooting.
- 38.) **Alarm Time** - how long a row must be outside of the specified tolerance before the alarm sounds.
39. **Re Alarm Interval** - The time before the Alarm alarms again after being acknowledged. If the issue that triggered the alarm is not resolved, it will keep alarming at this interval until resolved (if the box is checked).
40. **Bus Update Interval** - Use this to slow down ISOBUS traffic if the BUS load is too high. *Reset only after talking to a SurePoint representative.*
- 41.) **Flow Module Diagnostics** and **Valve Module Diagnostics**- These are addressed on previous page. Press one of these to go the Module Addressing screen.
- 42.) **Store Object Pool** - Stores the current ISOBUS layout on the VT.
- 43.) **Delete Object Pool** - Deletes the current object pool on the VT and forces the monitor to regenerate the display when it is rebooted. This may be necessary after a software update or feature unlock or if some screens or features do not appear correct.
- 44.) **Next VT** - press to push Sentinel to another virtual terminal. This may be necessary if there is more than one monitor or display in the cab.

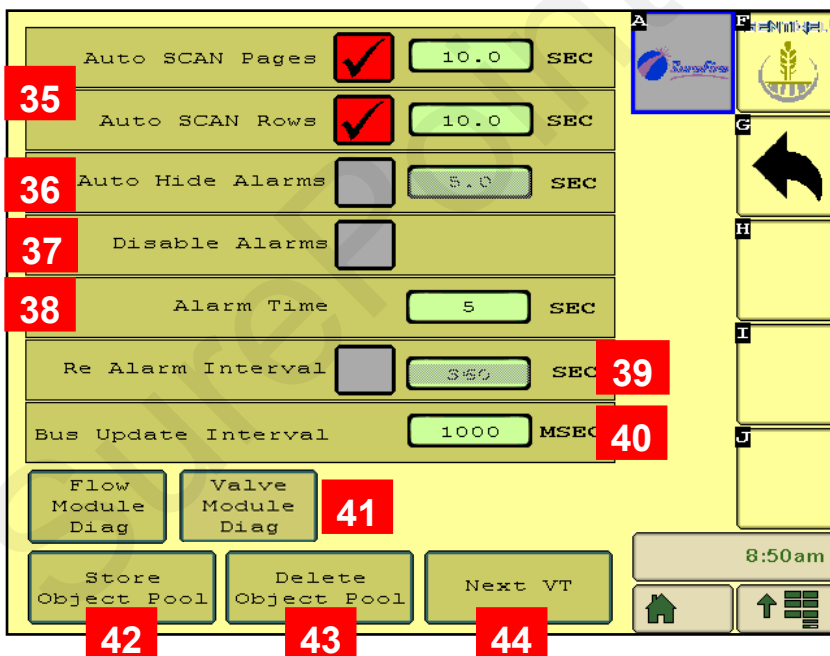

Next VT icon from v.1.3.0



Save to this VT from v.1.3.0



SETUP for Row Control - SETUP - Control Speed - Flow Cal - PWM Max and Min

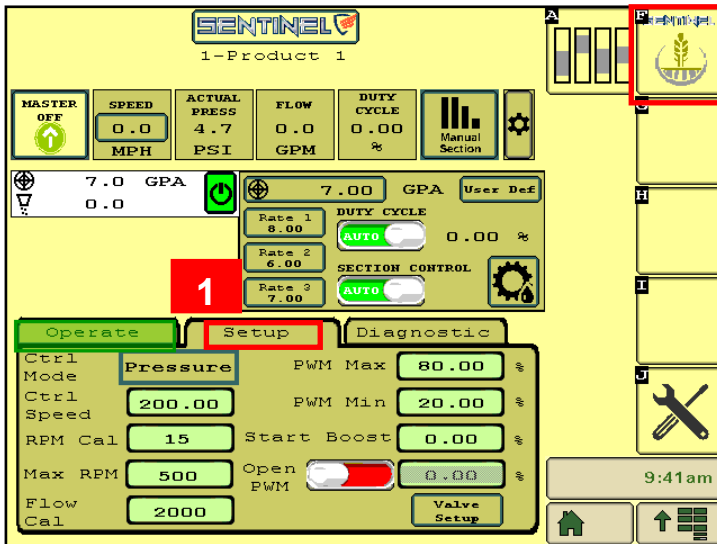

1.) Press the center **SETUP** tab.

Start with the following settings. Adjust as needed.

Ctrl Mode - PRESSURE

Ctrl Speed - Start at 500 for PR hydraulic pumps
Tower Electric - 2000 - 3000

Adjust as needed in the field. Increase the Ctrl Speed if the pump is slow to adjust. Decrease the Ctrl Speed if the pump fluctuates and the PWM Duty Cycle does not settle into a narrow range going across the field.

RPM Cal - 15 (for hydraulic pumps equipped with RPM sensor)

Max RPM - 500 (Can be set to 550 if needed)

Flow Cal - 2000 - most PR hydraulic pump systems
0.6 to 13 gpm flowmeter and larger.
3000 - most electric pump systems
0.3 to 5 gpm and smaller

(Flow cal number is on serial number sticker on side of flowmeter)

PWM Max - 80 to 100

PWM Min - 20-25 for most hydraulic pumps.
5-10 for most electric pumps.

Start Boost - usually 0. Can be set slightly higher than normal PWM Duty Cycle for a startup boost.

Open PWM - Normally RED. Turn to GREEN if you want the pump to continue running for product agitation while you turn around. When doing that, enter a PWM % to set the pump speed for agitation (usually 30-40%)

2.) DIAGNOSTIC TAB - Observe the system parameters during operation.

3.) **SurePoint** - press for version information

4.) Press starburst for Auxiliary Settings Screen and to enter Unlock Code.

Do not use this screen without authorization.

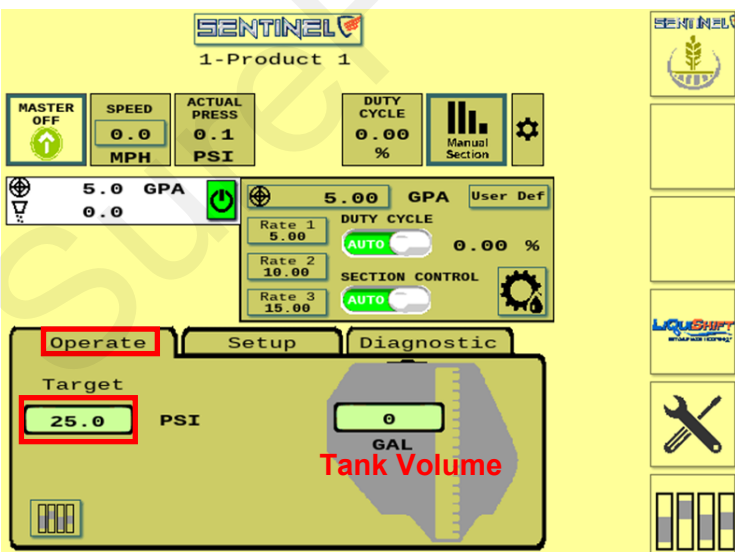
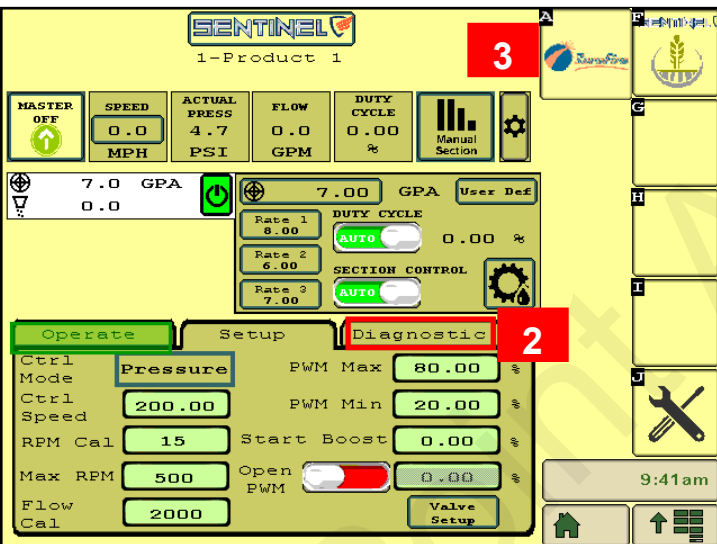

Operate Tab:

Target Pressure: Start with pressure at 30 PSI. Typical range will be from 20 to 45 PSI. Experiment for smoothest operation with quick adjustment.

Tank Volume: Enter tank volume when tank is filled. This screen will show volume remaining in tank.

Valve Setup

SETUP : Valve Setup:

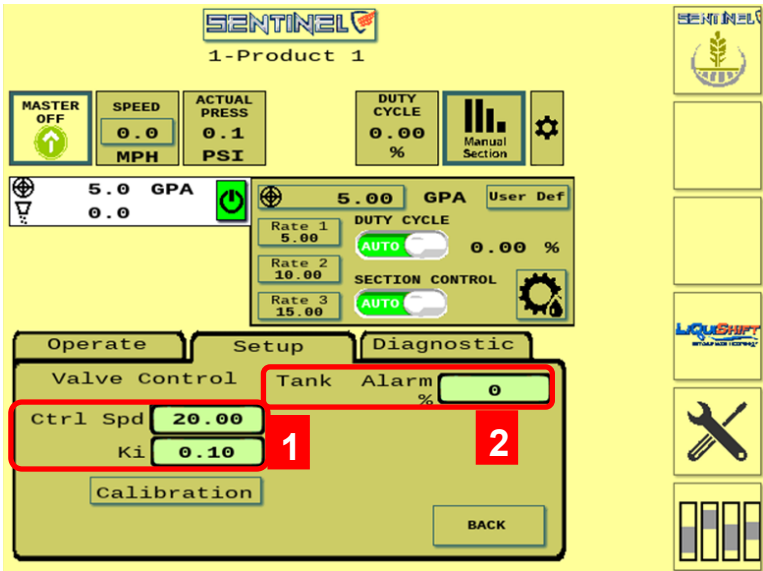

1.) **Ctrl Spd** (Valve Control) - if the rows seem to be bouncing around the rate on a normal pass, lower the Ctrl Spd. If the rows are slow adjusting to a rate change or speed change, increase the Ctrl Spd.

Ki - If the rows consistently stay slightly above or slightly below rate, increase this. These values should not need much adjustment.

2.) **Tank Alarm** - Enter a percentage of tank volume (say 10%) for an alarm when the tank reaches that level. You must enter the tank volume on the Operate tab when the tank is filled.

Row Detail Screen

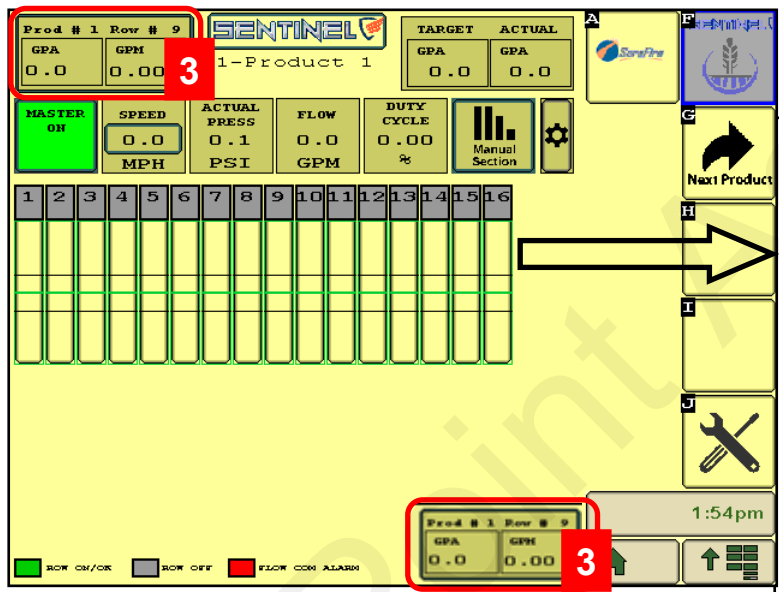

3.) Pressing the Row Detail button (may be top left corner or bottom right) on the Run screen brings up the Row Detail Screen.

The bar graph for Rows 1-16 shows the flow in each row at that instant.

A thin green line means the flow varies less than the Smoothing Factor % from the correct amount.

A thicker green line means the flow on that row varies by more than the Smoothing Factor % but less than the Tolerance %.

A red bar indicates the flow on that row varies by more than the Tolerance % set up for that product.

Example: Smoothing Factor - 10%
Tolerance - 20%

Flow less than 10% variance - thin green line
Flow with 10-19% variance - thicker green band
Flow more than 20% variance - red band

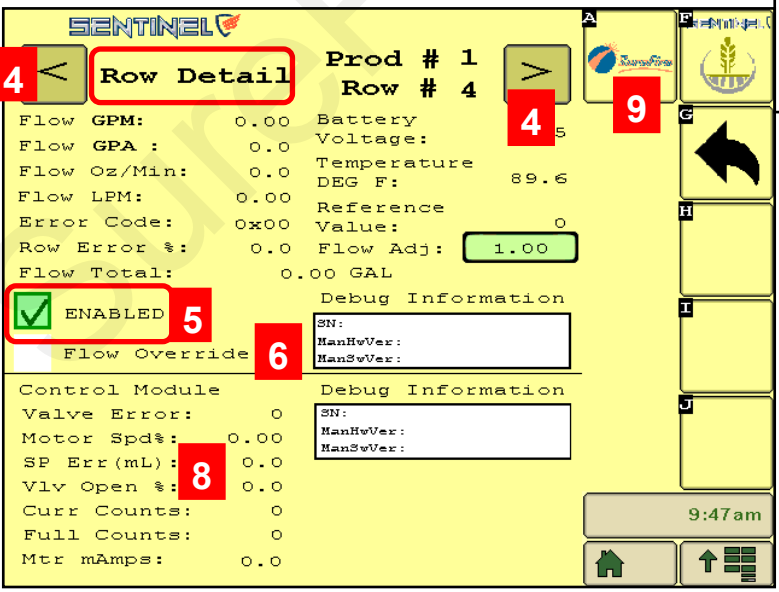

4.) Press the Left Arrow or Right Arrow to see details for other rows.

5.) A Row can be ENABLED or DISABLED by checking or unchecking the **ENABLED** box.

6.) Flow Override - use if flowmeter on row fails

7.) **Flow Adj** for this row only. Normally 1.00.

8.) Row Control Module information that may be helpful for SurePoint tech support.

9.) Press the SurePoint button to go to the Software Version and Auxiliary Settings screens.

ECU Software Version - Auxiliary Settings Screens - Feature Unlock

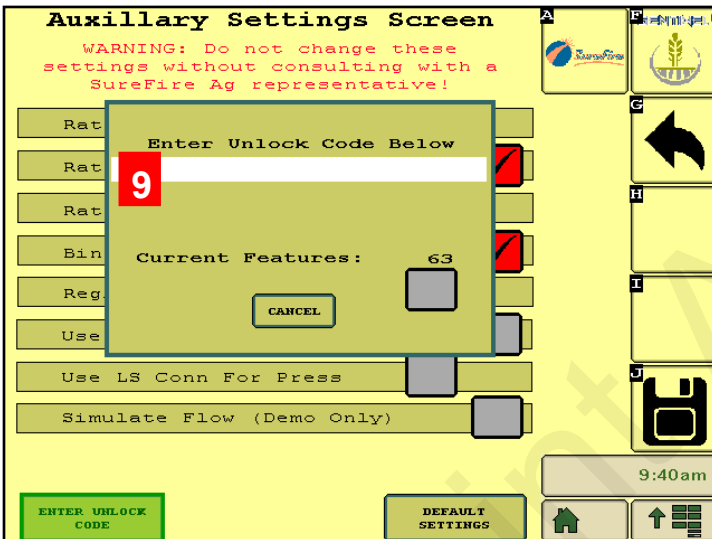
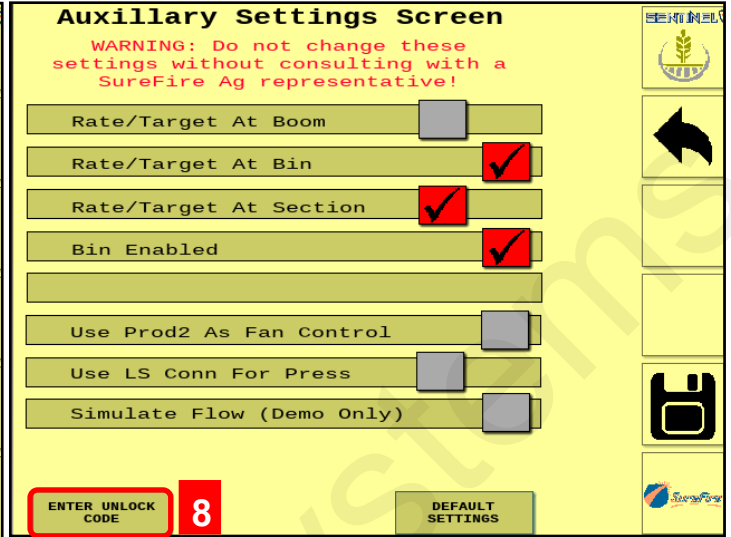
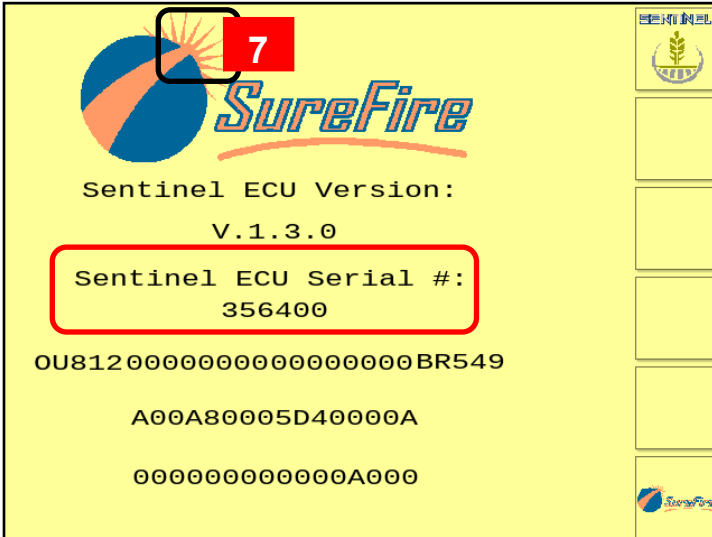

7.) Press on the sunburst to go to the Auxiliary Settings screen. Do not change this screen without directions from SurePoint technical support.

8.) If the ECU has not been unlocked to do Row Control, press Enter Unlock Code. An unlock code must be obtained from SurePoint. Contact SurePoint and provide the ECU Serial # to get the unlock code.

9.) Enter the unlock code obtained from SurePoint.

Sentinel Feature Unlocker (SurePoint Tech Support Only)

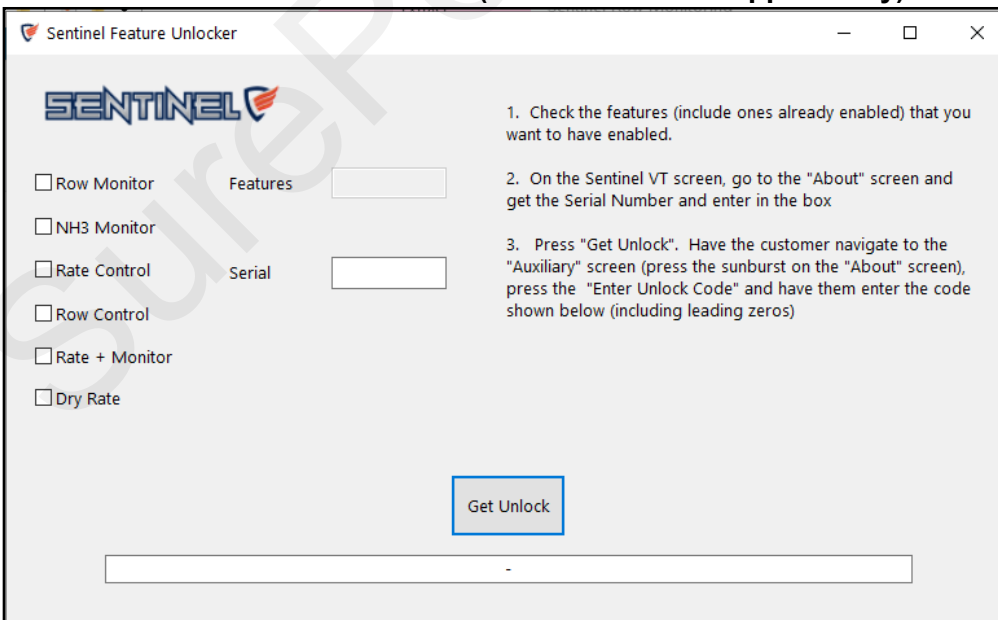

Customizable Toolbar & Totalizer Counters - Acres - Hours - Gallons

Sentinel has 3 totalizer counters to keep track of acres, hours, and gallons.

Any of these may be set up on the Customizable Toolbar near the top of the Product Run Screen. If these are not on the Customizable Toolbar, the values may still be seen by pressing the *Reset Totals* button on the Rate Setup screen. The items may be individually reset to 0 by pressing the Reset Total button for that item, or the totals may be left unchanged by returning to the Run Screen without resetting the values.

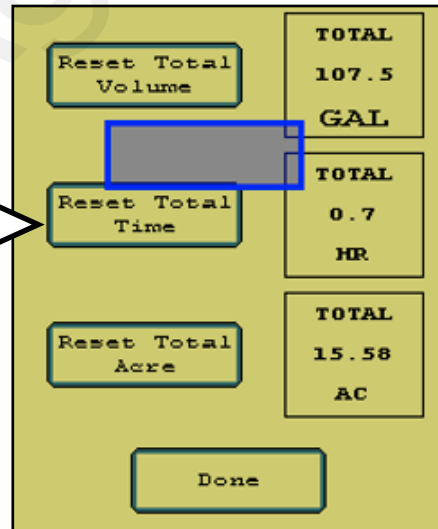
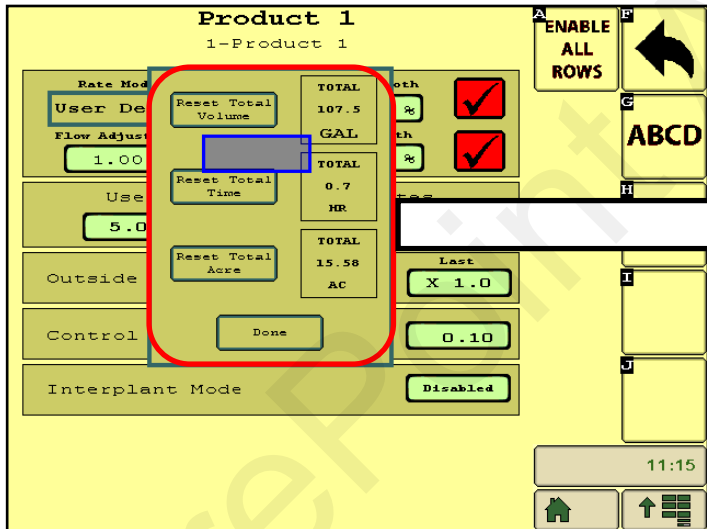
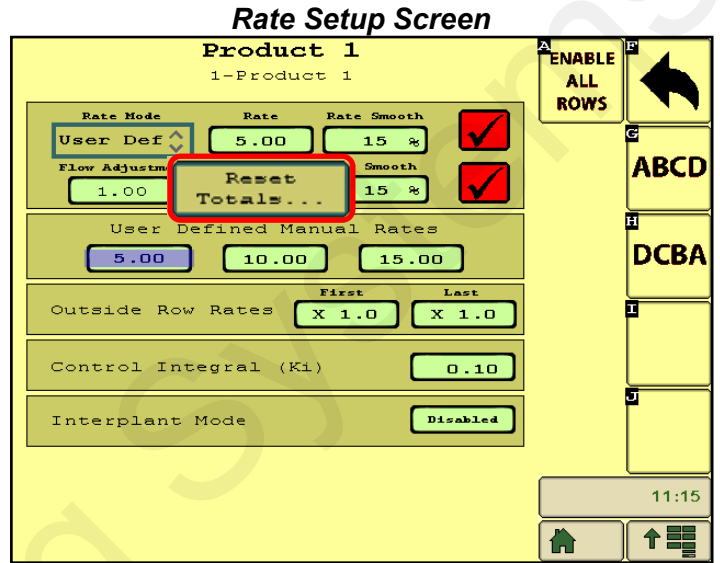
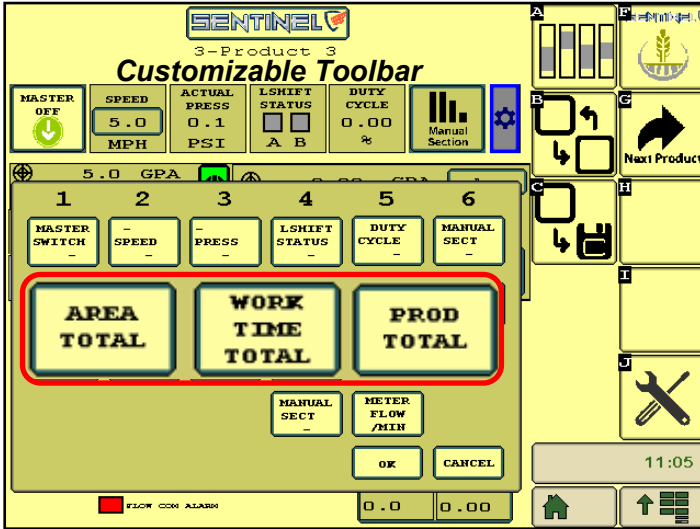

Sentinel Row Control & Row Monitoring Operation

1.) When operating with RATE CONTROL and ROW FLOW MONITORING, the Wheat button in the top right corner gives you the top half of the screens below.

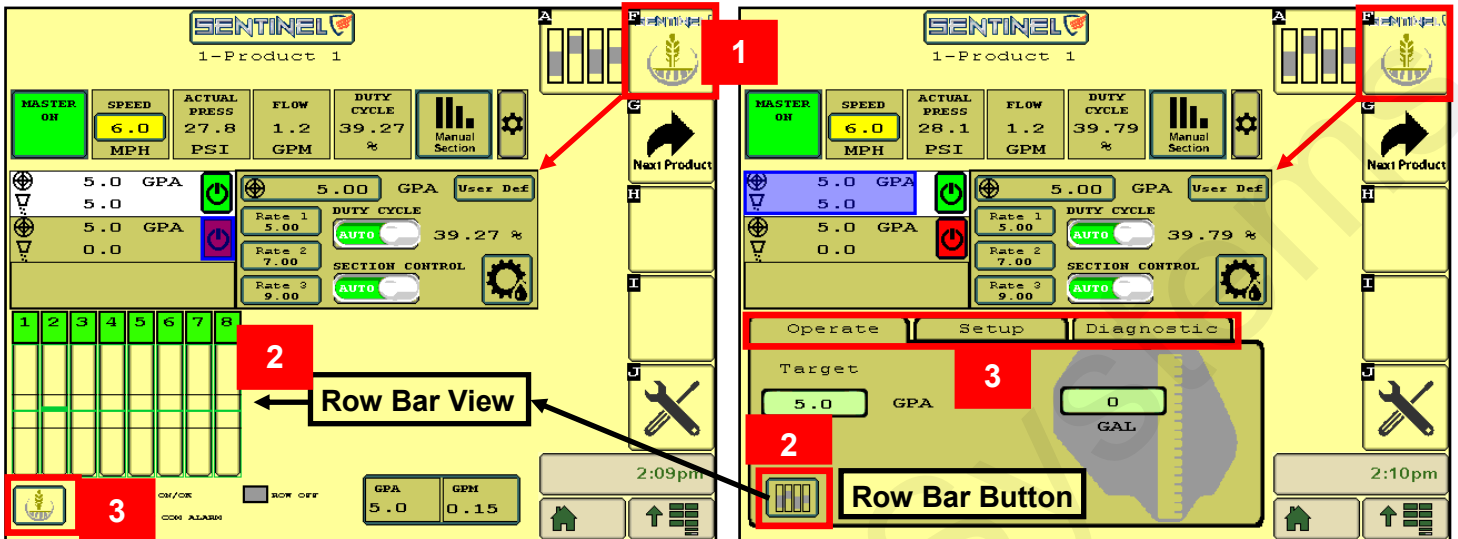

2.) Pressing the Row Bar Button in the lower left corner gives you the Row Bar View on the bottom half of the screen. 3.) Pressing the Wheat button in the lower left corner gives you the bottom half of the screen with Operate > Setup > Diagnostic tabs.

Typical Run Screen view for Row Control & Row Monitoring Operation

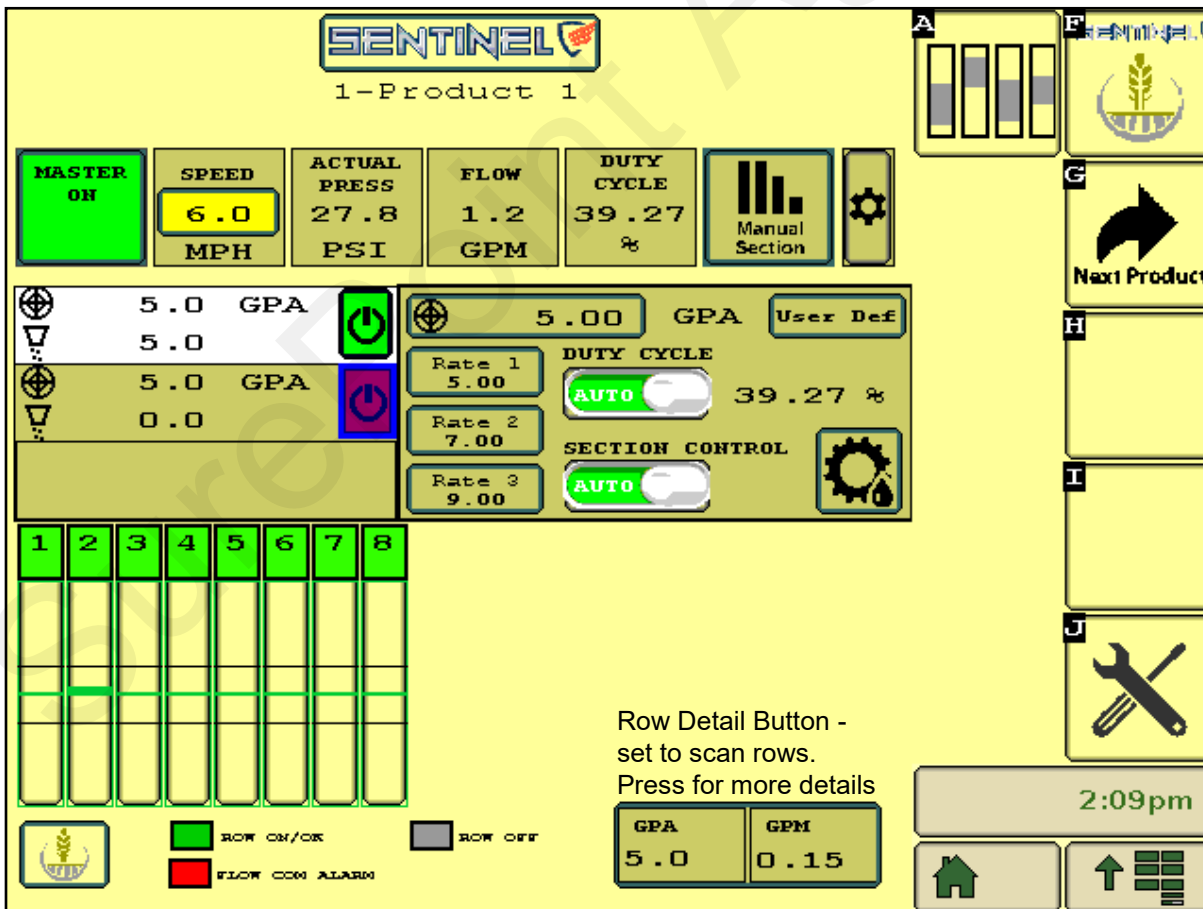

Sentinel Row Control Operation

Once the Sentinel has been set up in the display, little is required of the user to operate the Sentinel. The system can be started with an Implement Switch that will turn the system on when the implement is lowered. It can be turned on and off with a Master On/Off Switch (footswitch or on-screen). The system can also be turned on and off using Task Control to turn the system (or sections) on and off as the implement enters the field or overlaps previously applied areas using GPS location information.



Sentinel Wheat (Home) Button

On the HOME screen, the top row is a Customizable Toolbar with options to display several different system parameters.

The center section shows the Rate Control operation for each product. The user defined rates are available for selection on the go.

The bottom section has 3 tabs. Watching the information on the Diagnostic tab will help the user become familiar with normal operating parameters. Knowing what is normal can help the operator diagnose and fix the issue if a problem occurs.

Center Section - If operating more than one product, all products will be shown on the left side of this section.

Normal operation is with Duty Cycle and Section Control set to AUTO.

To run, there must be SPEED, Height Switch down, Master ON, target rate set, and a working width.

Toggle between Rate 1, 2, and 3 on the go, or press the top Target Rate box and enter a different target. Press the gear/teardrop on the bottom right to go to the Rate Setup screen.

To operate manually, press **Speed**, enter a speed, select **DUTY CYCLE MAN**, enter a DC% (minimum of 15 for electric, minimum of 30 for hydraulic),

Section Control: MAN. Master: ON. Height switch: DOWN (if used)

To test the system, you can change the Duty Cycle % as the pump is running. Observe the Flow (GPM) and Pressure with each Duty Cycle %. On an electric pump system, you can do this with one pump plugged in at a time to verify the operation of each pump. Look at the Diagnostic tab for more information.

Sentinel HOME Screen for Rate Control

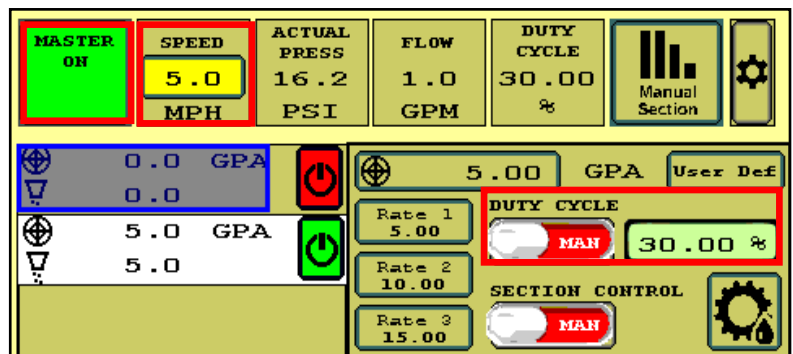
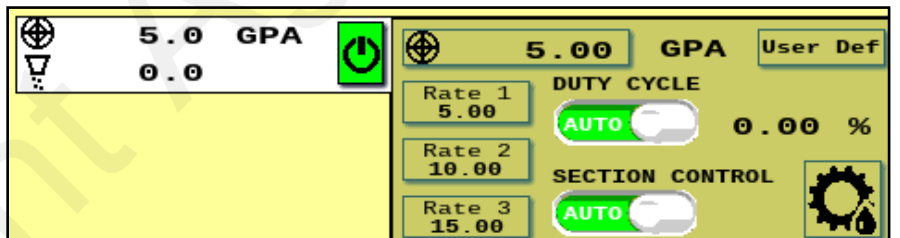
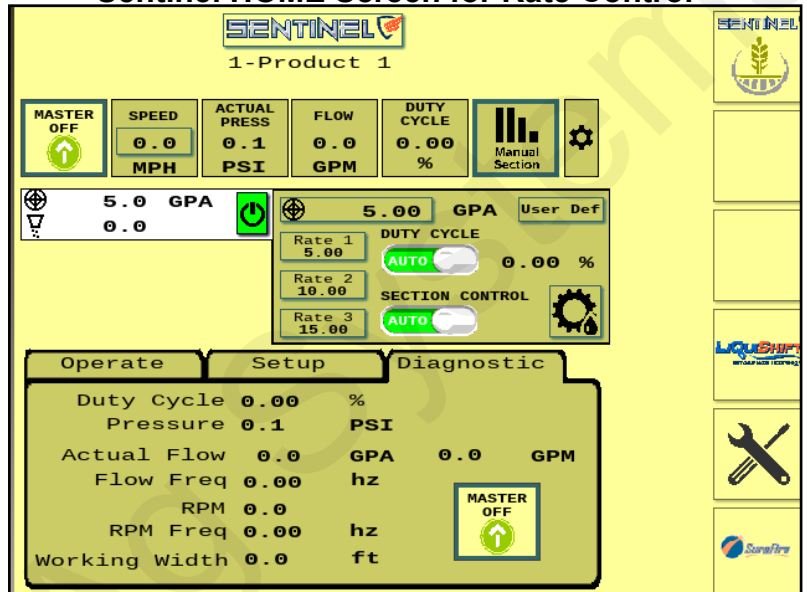

Sentinel HOME Screen for Row Control -- Setup and Diagnostic Tabs

Setup values are shown for typical **PR hydraulic** pump system. These can be adjusted as necessary for best operation.

Operate	Setup	Diagnostic
Ctrl Mode	Rate	PWM Max 80.00 %
Ctrl Speed	500	PWM Min 20 - 30 %
RPM Cal	15	Start Boost 0.00 %
Max RPM	500	Open PWM <input checked="" type="checkbox"/> 0.00 %
Flow Cal	2000	

Ctrl Speed: Decrease if pump (PWM Duty Cycle) surges or oscillates back and forth above and below the rate. Increase if pump is slow to adjust.

RPM 15

Start Boost - 0 (pump starts where it stopped) or set in field (enter PWM DC % for startup speed)

Diagnostic is a screen that can be seen while operating in the field or while testing. The important system parameters can be seen here.

Operate	Setup	Diagnostic
Duty Cycle	39.77 %	
Pressure	27.4 PSI	
Actual Flow	5.0 GPA	1.2 GPM
Flow Freq	60.32 Hz	
RPM	0.0	
RPM Freq	0.00 Hz	
Working Width	20.0 ft	

Diagnostic Tip: Note the relationship between Duty Cycle (%), Pressure, Flow (GPM), and RPM (hydraulic pump). If Duty Cycle and RPM increase above what is normal for a given flow, there could be a restriction on the inlet side of the pump. This could be a plugged strainer or a strainer that gets gelled over, especially with cold fertilizer.

Increased Duty Cycle with no increase in RPM could mean the pump is not getting enough hydraulic flow to spin the pump faster.

Diagnostic: (PWM) Duty Cycle shows the PWM signal sent from the controller to control the pump. On a hydraulic system, this needs to be around 25% before the pump will run. 40%- 50% is a typical operating range. On a normal pass this should be fairly stable ($\pm 2\%$). The Duty Cycle will adjust for speed, rate changes or width changes (sections going on and off).

Actual Flow shows the GPA being applied based on the Speed and the Machine Width.

Flow is the GPM measured by the flowmeter.

Flow Freq shows the number of pulses per second (Hz) being received from the flowmeter. This should be fairly stable (± 2). When diagnosing flowmeter issues, watch this number during a tap test to see if the signal gets from the flowmeter harness connector to the display.

RPM shows the pump RPM on a hydraulic pump equipped with an RPM sensor. This should be less than 500. Can be set at 550 if maximum pump output is required. **RPM Freq** shows the signals received from the RPM sensor. This can also be used during a tap test on the Pump RPM harness connector.

Watch these values regularly during operation so you know what "normal" looks like. For example, a plugged strainer could mean the pump has to run faster than normal to get enough product. This will show up in an increased Duty Cycle and RPM.

Working Width will change as sections turn on and off. It should show the application width at any time.

Setup values are shown for electric pump system (usually not used on Row Control systems). These can be adjusted as necessary for best operation.

Operate	Setup	Diagnostic
Ctrl Mode	Rate	PWM Max 100.00 %
Ctrl Speed	2000	PWM Min 10.00 %
RPM Cal	15	Start Boost 0.00 %
Max RPM	500	Open PWM <input checked="" type="checkbox"/> 0.00 %
Flow Cal	3000	

Flow Cal for big electromagnetic flowmeter.

Decrease **PWM Min** if pump will not slow down enough for low speed/rate/width.

Check the **Diagnostic** screen regularly so you have an idea what "normal" operating numbers are. This can help when you need to troubleshoot an issue.

Operate	Setup	Diagnostic
MASTER ON	SPEED 6.0 MPH	ACTUAL PRESS 27.4 PSI
	FLOW 5.0 GPA	FLOW 1.2 GPM
	DUTY CYCLE 39.77 %	
	Rate 1 5.00	Rate 2 7.00
	Rate 3 9.00	
	DUTY CYCLE AUTO	39.77 %
	SECTION CONTROL AUTO	
Duty Cycle	39.77 %	
Pressure	27.4 PSI	
Actual Flow	5.0 GPA	1.2 GPM
Flow Freq	60.32 Hz	
RPM	0.0	
RPM Freq	0.00 Hz	
Working Width	20.0 ft	

SETUP for Rate Control - TESTS - Nozzle Test (v 1.3.0 and later)



From the Product Setup page press the Nozzle Test icon.

Be sure MASTER is OFF. Press NEXT.

Select which sections you want to run for this test. NEXT .

Enter SPEED and RATE. NEXT.

Turn MASTER ON to start the test. Monitor Actual Rate, Pressure, Flow per Minute, Duty Cycle and Pump RPM.

To stop the test, turn MASTER OFF.

If only a few rows are on, the system may struggle to maintain a smooth output and rate.

When testing with water, the pressure will be less than it will be with a heavier, thicker fertilizer.

Increase the speed or rate to increase the pressure.

Sentinel Row Control Troubleshooting

Section Test or Manual Section Valve Operation and Manual Pump Operation

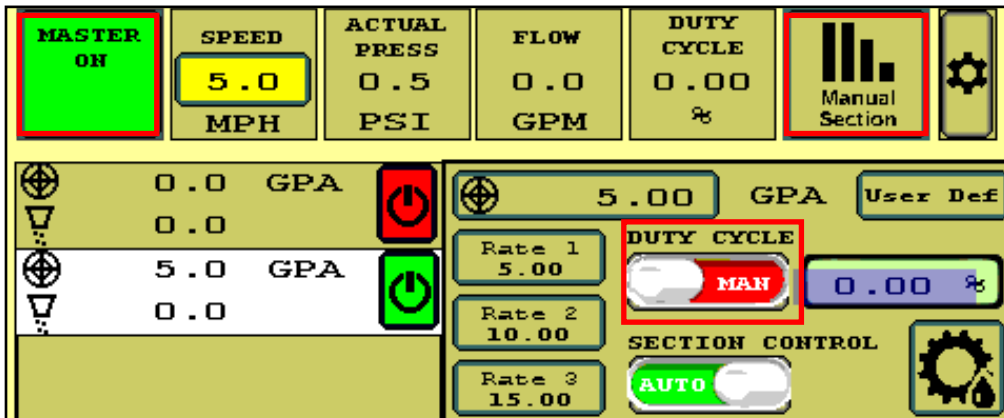

To operate the Section Valves manually, press **Manual Section**, then press any section button to turn the valve off/on.

To test the valves sitting still, put **DUTY CYCLE** to **MAN**, **MASTER** must be ON, and there must be a **SPEED** entered to actually open the valve.

To run the pump while doing this, enter a number for the Duty Cycle %. The Flow (GPM) and Pressure should be steady. Adjust DC%.

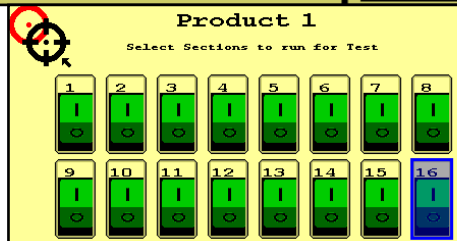

Manual Section Control:

Press to turn row ON or OFF.

1. Enter a **SPEED** (tap the box and enter).
2. Select a **RATE**.
3. **Master ON**. May need to turn Auto Section Control off. Height switch down if using.
4. Adjust **SPEED** and **RATE** to test range.
5. Observe Flow (GPM), Pressure, and Duty Cycle %. On hydraulic pump observe RPM.
6. When testing with water, the pressure will be much less than it will be with a heavier fertilizer. You may have to increase the rate significantly to open all the check valves so all rows will flow.
7. You can go to Manual Section (on the top row) and close some sections to see system response.
8. If Duty Cycle / Rate / Flow oscillate and won't lock in, decrease the Control Speed on the Setup Tab (adjust electric pump by 500, hydraulic by 50). Adjust Control Speed as needed for best field performance. (In some cases, the Control Speed for the row valves may need to be adjusted.)

AUTO Test Operation

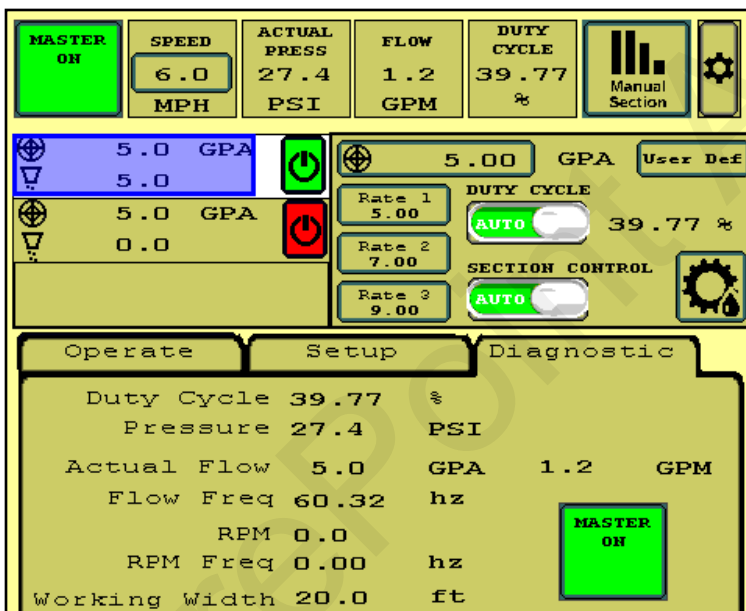

System Won't Run

1. Is **MASTER ON**? Is there a **SPEED**? Is there a **RATE**? Switch Section Control from **AUTO** to **MANUAL**.
2. On **Hardware** screen, uncheck **TASK CONTROL**. If you have **TASK CONTROL** checked on the Sentinel, Task Control must be activated and turned ON on the display software.
3. Verify settings for Master Switch and Implement Switch. If these boxes are checked, these items must be plugged into the Sentinel harnessing, not into harnessing for another control module. If using an **IMPLEMENT SWITCH** for Sentinel, is the orientation correct (check arrow on **MASTER ON** button)?
4. If there is a DC% showing, but the pump is not running, check the hydraulics or the EPD on an electric pump system. Verify there is voltage on the 2-pin PWM Connector.

Hydraulic Pump Will Not Turn

Turn hydraulics off, go to the **SurePoint Hydraulic PWM valve** and use the manual override (red knob) on top of the electric coil to **manually open the valve** (Manual Override UP = valve fully open). There may be dirt in here that needs to be cleaned out before you can turn and raise the override. Start the **Manual Operation mode** to open the section valves. Turn hydraulics on **at a low flow only** as the valve is 100% open. Gradually increase the hydraulic flow from the cab. If pump does not turn, try hydraulic lever in opposite direction. Try switching to a different remote. Does the pump turn? If it turns, your problem is electric / electronic. If the pump still does not turn, you have a hydraulic problem.

Electric / Electronic Problem

1. Close manual override (lock down)
2. Run the system in **Manual Operation mode** to investigate this issue.
3. Verify hydraulics are on.
4. In Manual mode, increase the PWM Duty Cycle (to 40-45%).
5. Take a metal object and hold it next to the coil. If the coil is working, you will feel the magnetic pull.
6. If no magnetic force is felt, disconnect the PWM valve connector and check voltage. You will need 8-12 volts to get hydraulic valve to open.
7. If 8-12 volts is not present, check harnesses and review control valve type setup.
8. Go back to the 12-pin connector that plugs into the Pump harness. Check voltage between pins 5 & 6 and pins 5 & 2.
9. You can remove the electromagnetic solenoid with proportional valve to see if the valve moves when a PWM signal is sent to it. Look closely, it's a small movement.



Hydraulic Fluid and Equipment Safety

This system uses hydraulic equipment with hydraulic fluid under extremely high pressure. Hydraulic fluid escaping under pressure can have sufficient force to penetrate the skin causing serious injury. Use a piece of paper or cardboard, NOT BODY PARTS, to check for suspected leaks. Wear protective gloves and safety glasses or goggles.

Hydraulics Problem

1. Leave the manual override open on the SurePoint valve.
2. Check the hose routings. The "P" port on the SurePoint valve should hook to pressure. The "T" port is the return that should flow back to the tractor.
3. Try hoses in a different hydraulic remote. Inspect hydraulic connectors for damage or restrictions.

Hydraulic Manual Override

Down - Normal Operation

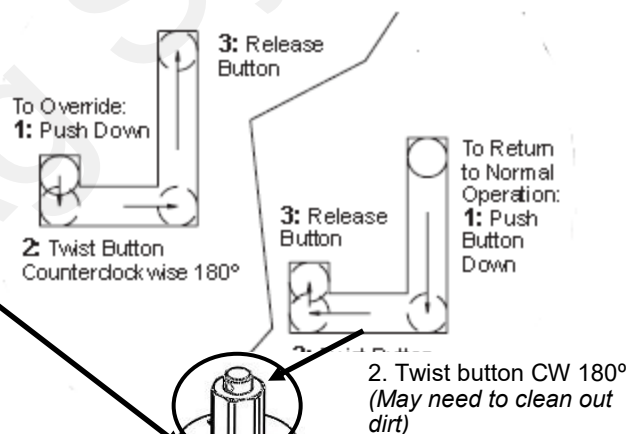

Coil Check: Should be 7-9 ohms between the two pins on the PWM connector on the coil.

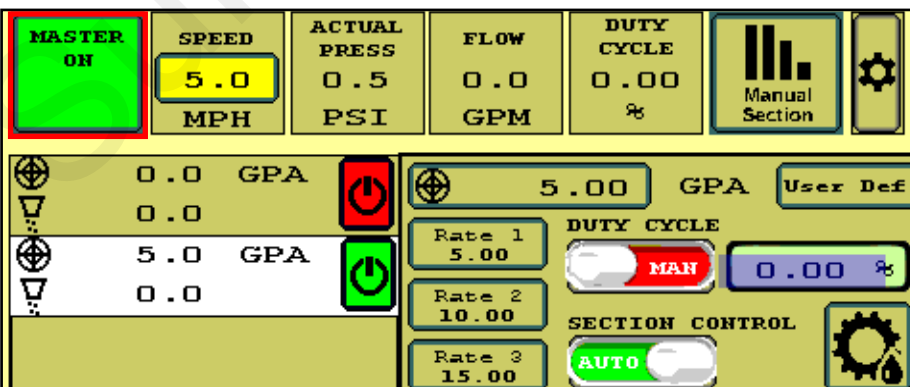
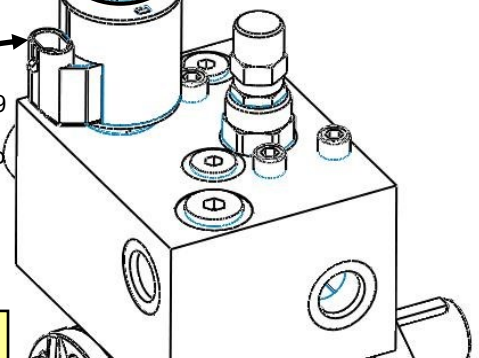

Manual Operation Mode:

1. Enter Speed
2. Select Rate
3. Duty Cycle - MAN - enter 30+%
4. Turn Section Control - MAN
5. Master ON -Height switch down

Sentinel Troubleshooting

Sentinel doesn't show up on my display

1. Verify that the Sentinel ECU has power - 2 green lights should be illuminated on the ECU.
 - A. Using a voltage tester, check voltage on the ECU harness.
2. Check connections:
 - A. Tractor ISO plug
 - B. CAN and power connections leading to the ECU harness
3. Reboot everything.

Sentinel flow module(s) will not address

1. Make sure that the trunk lines are plugged into the correct port on the module.
2. Be sure the tractor is running. Low voltage may cause modules to not address.
3. Make sure that you have all the modules plugged in before touching **RESET ALL ADDRESSES**
4. Unplug ALL modules for that Product and plug the modules in one at a time, making sure the previous module addresses before moving on to the next.
5. *Verify that the lights on the module are flashing. If there are no lights, there is no power to the module.*
 - A. If the module lights do not light up, check the connection to the module and inspect all connections to the ECU harness.
 - B. If all connections look good, use a voltmeter to check voltage to the module using the harness drawings.
 - C. If 12 volts is present and module fails to light up, the module may be faulty.
6. Reboot everything.

When addressing modules, one or more modules flash green or stay blue

1. Make sure that the implement is set up with the correct number of rows.
 - A. If a module is plugged in that the Sentinel is not expecting, it may flash blue/green to signify that it is addressed, but not expected. Not all ISO displays will respond this way.
2. If your implement is configured with a number of rows not divisible by 4, the last module will not show as "expected". For instance, in the case of a 6-row potato planter, 2 modules are used but only 2 rows are plumbed on the second module. When addressing, module 2 will display as "not expected." When plugged in, it will be issued an address and 6 rows will display on the Sentinel HOME screen. The last 2 rows on the module will be ignored.

Sentinel shows no flow and rows are grey

1. Make sure the **MASTER** button on the Sentinel **HOME** screen displays **MASTER ON**. If not, touch the button to cycle it.
2. Is Sentinel disabling the rows?
 - A. Go to the **HARDWARE** page. If **USE LIFT SWITCH** box is checked, and a dedicated lift switch is not installed, the Sentinel is disabling flow on all rows because it thinks the implement is up. Uncheck the **USE LIFT SWITCH** box. If a dedicated lift switch is installed and plugged into the Sentinel ECU harness, the switch may need adjusted to correctly show the implement status. If a lift switch is used that is normally closed, the **INVERT LIFT SWITCH** box needs to be checked.
3. Are you performing a stationary flow test? If so, a simulated speed must be entered and Section Control must be MAN.
4. Is a speed being displayed on the Sentinel **HOME** screen when moving?
 - A. If not, change the speed source.

Sentinel Row Flow Troubleshooting

Sentinel alarms too often

Often times during initial start-up the Sentinel alarms can seem excessive as Sentinel highlights the row-to-row inaccuracies in the system. Small things like tubing lengths and check valve springs can make big differences in row-flow. To start out, a user may consider increasing the **TOLERANCE** up to 50% until these issues are resolved. Here are some other adjustments that can be made:

1. Decrease the length of time that full-page alarms display by changing the **AUTO HIDE ALARMS** setting.
2. Increase the time before a row alarms by increasing the **ALARM TIME** setting.
3. Is Sentinel alarming when the implement is up or when turning around?
 - A. Use the **IntelliSection** option
 - B. Consider disabling alarms with the use of a lift switch
4. Go to the **ROW DETAILS** and disable the problematic row
5. Disable all alarms by checking the **DISABLE ALARMS** box

Sentinel Doesn't display speed

1. Change the speed source. Toggle through the speed sources until speed displays.
2. If none of the speed sources are working, a communication problem with the tractor may exist. Consult your tractor dealer or add a GPS speed receiver found in the Accessories section of this manual.

Recommended Care and Maintenance



Cleaning

Under no circumstance should the Sentinel modules or ECU be cleaned with a pressure washer. While the flow modules and ECU are sealed, the intense pressure generated by pressure washers may penetrate the seals and cause irreversible damage.

Air Bladder

PumpRight pumps have an air bladder to smooth the pump output flow. It is recommended to run this bladder at 20% of working pressure. So, if your system operates at 50 psi, charge the air bladder to 10 psi. Due to the small size of the air bladder, **very little air is needed**. SurePoint recommends charging a portable air tank to the correct pressure, then attach to the bladder valve to charge the air bladder to the same pressure as your air tank.

Winterization

SurePoint recommends flushing your fertilizer pump and complete system with adequate amounts of water first. Next, use RV antifreeze to winterize your system by pumping an adequate amount through all components. At the beginning of the next season, begin with water to verify the system is in working order with no leaks.

Change Pump Oil Annually

PumpRight pumps use an internal oil lubricated crankshaft and connecting rod design. The oil is held in an external reservoir with level indicators. Hypro oil is recommended for the pump. This is a non-detergent SAE30 weight oil. If not available, hydraulic jack oils are a similar non-detergent formulation. Annual oil changes are recommended.

To fill or drain the pump completely, the pump shaft must be turned slowly by hand. The hydraulic motor will have to be removed to do this.

On some pump models, the pump will have to be removed from the mounting bracket and lifted slightly to allow access to the oil plug.

When refilling the pump with oil, the shaft will again have to be rotated to fill the pump to its required oil volume.

CRANKCASE OIL CAPACITIES				
Model	Capacity		Model	Capacity
PR17	13 oz		PR40	56 oz
PR30	28 Oz		D250	98 oz

Diaphragm & Valve Replacement

PumpRight pumps are designed to allow very simple replacement of the two main pumping components; the diaphragms and the inlet & outlet valves. It is a good practice to replace these every 3 or 4 years (or every 1000 hours). It is a small job that helps ensure reliable operation during the busy season.

Pre-season Service

(A little time spent here may prevent some downtime when you want to be rolling.)

1. Visually check entire system (hoses, fittings, harnesses, etc.) for any signs of wear or trouble.
2. On the display, recheck all setup screens (see Section F) to verify correct setup.
3. Fill system with water and run in Manual mode (Section Test or Calibrate PWM Limits) to verify components and system are in working order. (May need to open air bleed valve to prime pump the first time. Be sure air bleed tube is not plugged.)
4. **Clean out the dirt that may be packed in to the manual override knob on the hydraulic valve block.**
5. If necessary run pump in manual override mode to check hydraulic setup (see page 39).
6. Tighten all clamps. Loose clamps may be evident by leaks on the output side of the system. Loose clamps from the tank to the pump are not always apparent, but can be sources of air getting into the system which can create issues.
7. Push in tubes at all Quick-Connect fittings so they are seated tightly. Tubes that are not fully seated are not always obvious, but may allow air in, which can cause check valves to leak.
8. Remove the black cap from the top of each check valve. Check the diaphragm to be sure it is intact and not gummed up with residue. Look under the diaphragm for debris. Compress the spring in the cap to be sure it moves freely. Carefully replace diaphragm and tighten cap.
9. Remove and clean the strainer. Be sure strainer is tightened securely so it will not suck air.
10. Be sure all rows are flowing and that all metering tubes/orifices are open. (Note: It will take a higher flow rate with water to create enough pressure to open all the check valves.)
11. Run an Auto Check or Nozzle Test to verify that system will lock on to a Target Rate.

H

Maintenance



DANGER

Hydraulic oil under extremely high pressure. Do not use hand or any other skin to check for or to stop hydraulic leaks. Be sure pressure is relieved before loosening hydraulic fittings. Replace worn hoses immediately. Seek medical care immediately if hydraulic oil is shot into the eye or the skin.



CAUTION

These pumps can deliver liquid at high pressure (290 PSI). Be sure the 100 PSI Pressure Relief Valve (PRV) is installed and functioning so system pressure will be kept under 100 PSI. Check hoses, hose clamps, and liquid fittings regularly and repair or replace loose connections.

PumpRight Valves & Diaphragms

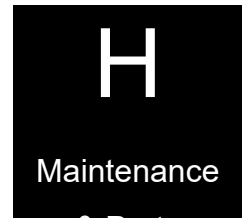

Diaphragm Pump Service Kits

1 Kit contains 1 diaphragm and 2 valves to service a single pumping diaphragm.

Order multiple kits to service all the diaphragms in your specific pump per chart below...

For other service parts, see individual Pump Part Breakout Diagrams in [396-4034Y1](#), the PumpRight manual that came with your pump.

QTY in Kit	Part Number	Description
PR17 Pump Service Kit - 3 Diaphragm		
KIT #: 291-13-100100 (pump requires 3 kits)		
1	291-13-1040083	BlueFlex Diaphragm (PR17)
2	291-13-2429051	Valve
2	291-13-3460380	Gasket / O-ring

PR30 Pump Service Kit - 3 Diaphragm		
KIT #: 291-13-100150 (pump requires 3 kits)		
1	291-13-550081	BlueFlex Diaphragm
2	291-13-2429051	Valve
2	291-13-3460380	Gasket / O-ring

PR40 Pump Service Kit - 4 Diaphragm		
KIT #: 291-13-100150 (pump requires 4 kits)		
1	291-13-550081	BlueFlex Diaphragm
2	291-13-2429051	Valve
2	291-13-3460380	Gasket / O-ring

D250 Pump Service Kit - 6 Diaphragm		
KIT #: 291-02-100500 (pump requires 6 kits)		
1	291-13-550081	BlueFlex Diaphragm
2	291-02-9910-759051	Valve
2	291-02-680070	Gasket / O-ring

PR80 Pump Service Kit - 4 Diaphragm		
KIT #: 291-13-100250 (pump requires 4 kits)		
1	291-13-304083	BlueFlex Diaphragm
2	291-13-3049050	Valve
2	291-13-3040200	Gasket / O-Ring



Visit www.SurePointag.com or www.support.SurePointag.com for [PumpRight Diaphragm Pump Repair and Maintenance Video](#)

PumpRight Valves & Diaphragms

Diaphragm Pump Service Kit Replacement Instructions for PR Pumps

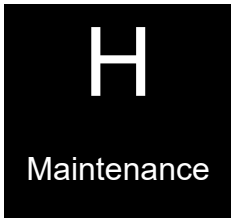

Visit www.SurePointag.com or www.support.SurePointag.com for PumpRight Diaphragm Pump Repair and Maintenance Vid-

	Number of Diaphragms
PR17	3
PR30	3
PR40	4
D250	6

Diaphragm & Valve Service Steps:

1. Remove inlet and outlet plumbing connections by unscrewing ring nut on inlet and outlet fitting.
2. Use extreme caution when removing and replacing drain plug, so that threads are not stripped and o-ring is not damaged. Remove drain plug from bottom of pump to drain oil from pump. Rotate pump shaft to remove all oil. Replace drain plug making sure o-ring is in place. Tighten plug to 180 In.Lbs.
3. Remove pump manifold(s) using a 13 mm wrench.
4. Remove and replace complete valve assembly.
5. Remove the pump head.
6. Remove the diaphragm bolt, support washer and diaphragm. Turn the pump shaft to up stroke to replace diaphragm.
7. Install new diaphragm (LIQUID side up), then replace washer and bolt.
8. Turn pump to downstroke to seat new diaphragm into the sleeve groove.
9. Replace pump head and manifold(s).
10. Refill crankcase with SAE30 non detergent oil (PumpRight Oil or hydraulic jack oil). Turn the pump shaft and top off sight glass.

NOTE: See individual Part Breakout Charts for Bolt/Nut Torque Specs.

Typical Manifold—2 per pump—inlet and outlet

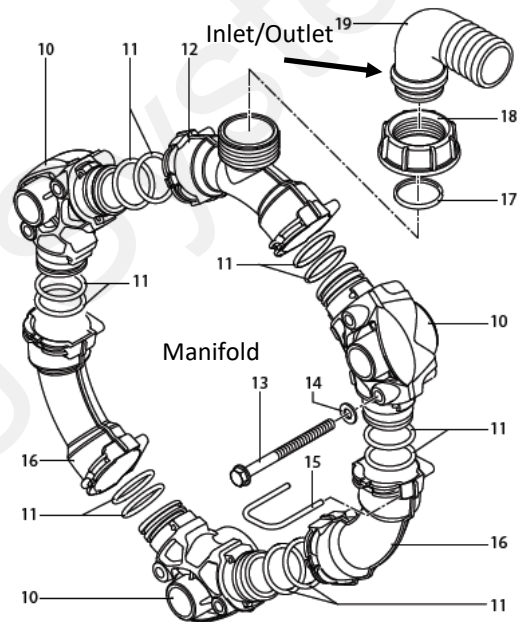

Typical Valve Assembly

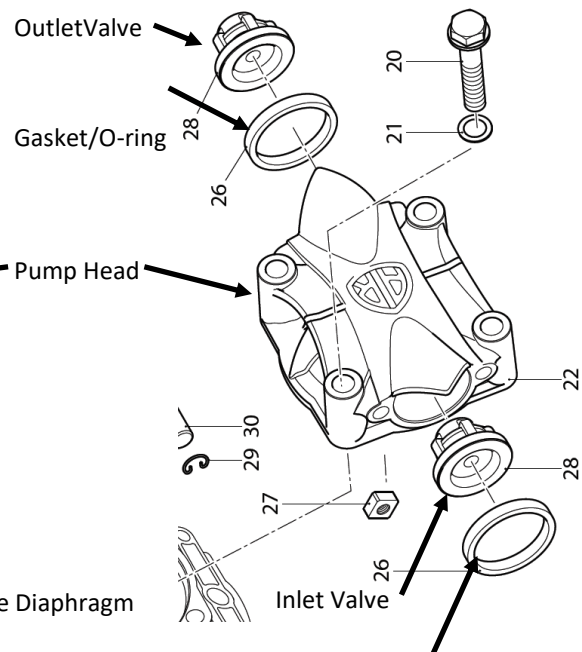

Typical Diaphragm Assembly

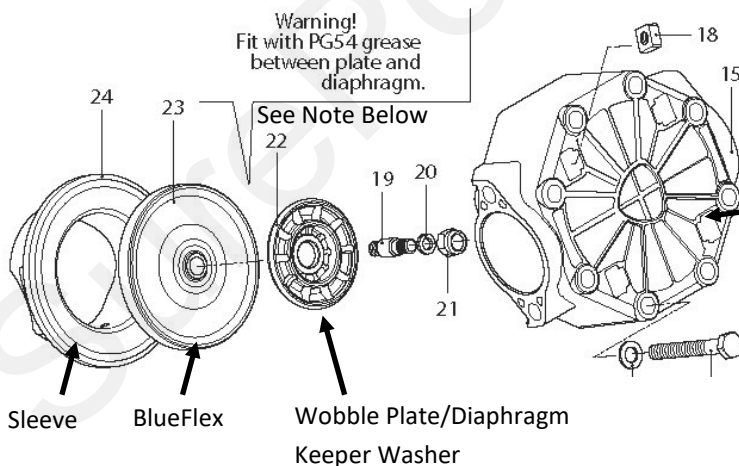

NOTE: A multipurpose grease is fine to use for applying in between the Diaphragm and Wobble Plate/Washer

For other pump service parts, see individual Pump Part Breakout Diagrams in [396-4034Y1](#), the PumpRight manual that came with your pump.

[Also see the manual and individual pump parts breakouts online here. \(store.SurePointag.com\)](#)

[Go to support.SurePointag.com for pump information and parts breakdowns.](#)

PWM Valve and Motor Parts

H

Maintenance

- 164-FTA0994 4.0 CID motor (this is the standard motor beginning in 2016)
- 164-FTA1609 Same as 164-FTA0994, but with RPM Speed Sensor--

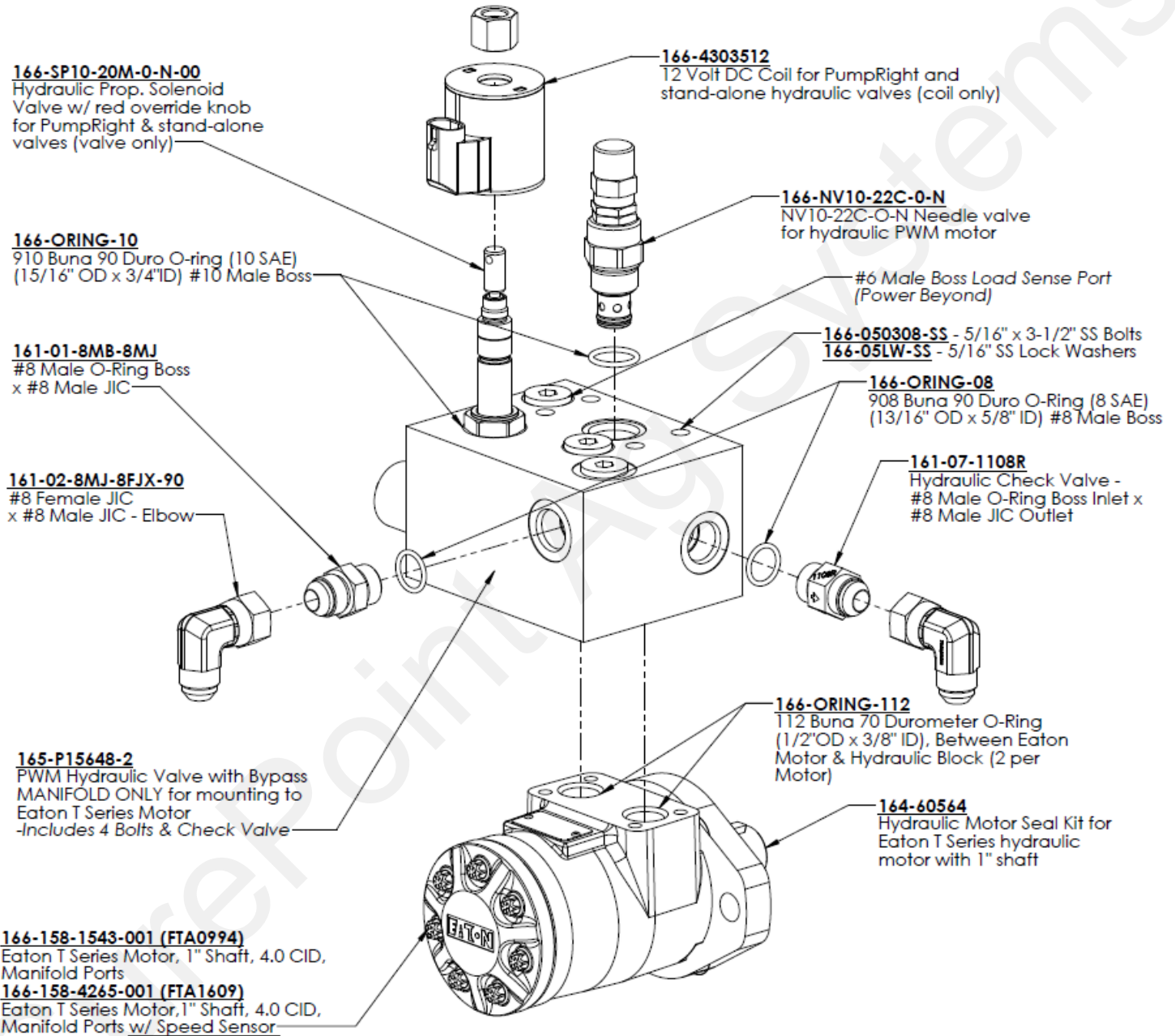

©2012-2022 SurePoint Ag Systems—All Rights Reserved