



396-5407Y1

Remote Pressure Tap

Assembly Instructions

Note:

Mount the pressure tap assembly within 3-4 ft of the pump/flowmeter to ensure the harness connection for the pressure sensor is long enough to connect. If desired, the pressure tap can be located further away from the pump utilizing harness extensions.

2-Pin Extensions	
Part Number	Description
206-02-13200	2-pin - 5' Extension Cable
206-02-13201	2-pin - 10' Extension Cable
206-02-13202	2-pin - 15' Extension Cable
206-02-13203	2-pin - 20' Extension Cable
206-02-13204	2-pin - 25' Extension Cable

3-Pin Extensions	
Part Number	Description
206-03-13205	3-pin - 5' MP Extension Cable
206-03-13206	3-pin - 10' MP Extension Cable
206-03-13207	3-pin - 15' MP Extension Cable
206-03-13208	3-pin - 20' MP Extension Cable
206-03-13209	3-pin - 25' MP Extension Cable

520-00-055800 - 3/4" Hose Pressure Tap Kit			
Item No.	Part Number	Description	Qty
1	100-075025RB	3/4" MPT x 1/4" FPT Reducer Bushing	1
2	101-075075075-HB-F	3/4" FPT x 3/4" HB Tee	1
3	113-06-025025	QC to MPT - 1/4" QC x 1/4" MPT	1
4	350-1208	SS Hose Clamp - Size 12 - 1-1/4" Diameter	2
5A	521-05-050150	3 Wire Pressure Sensor (0 - 5 V DC) with 3 pin 150 MP Tower Connector	1
5B	521-05-050100	2 Wire Pressure Sensor (4 - 20 mA out) with 2 pin 150 MP Tower Connector	1
6	396-5407Y1	Remote Pressure Tap Assembly Instructions	1

Installation Instructions:

1. Assemble fittings as shown.
2. Route 3/4" hose and tighten with hose clamps.
3. Plug 2-pin/3-pin pressure sensor connector into pump harnessing.

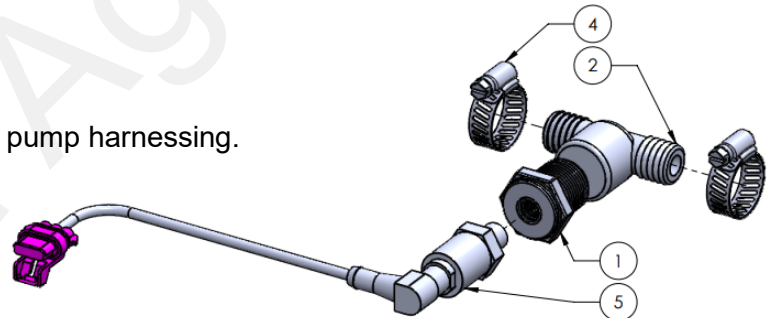

520-00-055850 - 1" Hose Pressure Tap Kit			
Item No.	Part Number	Description	Qty
1	105-100BRB	1" Manifold x 1" HB	2
2	105-100G	1" EPDM Manifold Gasket	3
3	105-100PLG025	1" Manifold Plug x 1/4" FPT	1
4	105-100TEE	1" Manifold Tee	1
5	105-FC100	1" Manifold Clamp	3
6	113-06-025025	QC to MPT - 1/4" QC to 1/4" MPT	1
7	350-1608	1" Hose Clamp	2
8A	521-05-050150	3 Wire Pressure Sensor (0 - 5 V DC) with 3 pin 150 MP Tower Connector	1
8B	521-05-050100	2 Wire Pressure Sensor (4 - 20 mA out) with 2 pin 150 MP Tower Connector	1
9	396-5407Y1	Remote Pressure Tap Kit Instructions	1

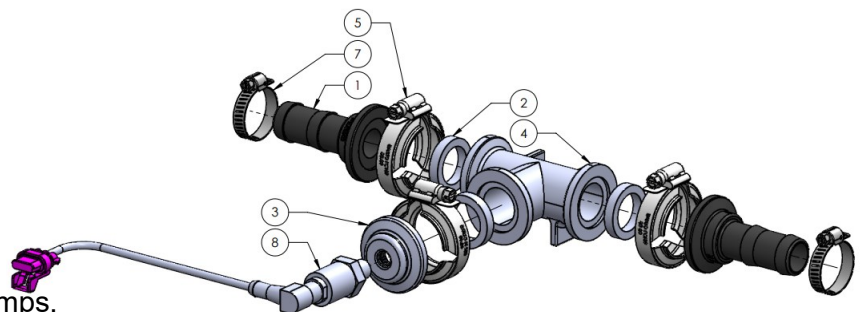

Installation Instructions:

1. Assemble fittings as shown.
2. Route 1" hose and tighten with hose clamps.
3. Plug 2-pin/3-pin pressure sensor connector into pump harnessing.



520-00-055900 - 1-1/2" Hose Pressure Tap Kit			
Item No.	Part Number	Description	Qty
1	105-150G	1-1/2" EPDM Gasket	3
2	105-200150BRB	2" Manifold x 1-1/2" Barb	2
3	105-200PLG025	2" Manifold Plug x 1/4" FPT	1
4	105-200TEE	2" Flanged Tee Fitting	1
5	105-FC200	2" Manifold Clamp	3
6	113-06-025025	QC to MPT - 1/4" QC x 1/4" MPT	1
7	350-PS238	Pressure Seal HD Clamp, Size 238 - 1.625" - 2.125" (1-1/4" - 1-1/2" ENF, WBS or AG200 hose)	2
8A	521-05-050150	3 Wire Pressure Sensor (0 - 5 V DC) with 3 pin 150 MP Tower Connector	1
8B	521-05-050100	2 Wire Pressure Sensor (4 - 20 mA out) with 2 pin 150 MP Tower Connector	1
9	396-5407Y1	Remote Pressure Tap Kit Instructions	1

Installation Instructions:

1. Assemble fittings as shown.
2. Route 1-1/2" hose and tighten with hose clamps.
3. Plug 2-pin/3-pin pressure sensor connector into pump harnessing.

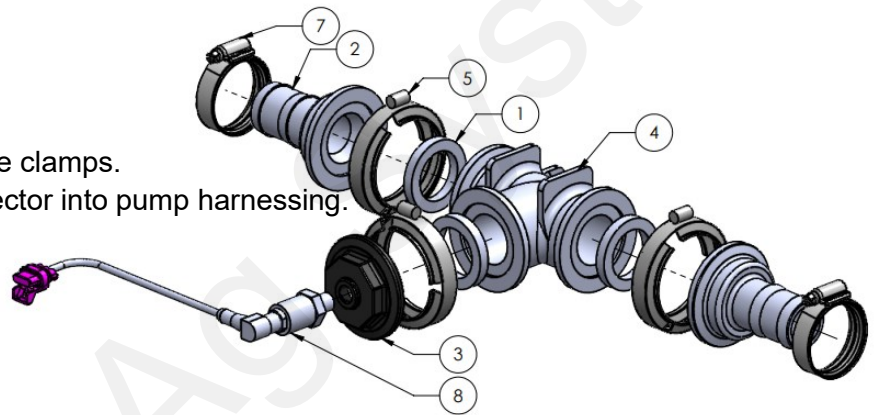

520-00-055950 - 2" Hose Pressure Tap Kit			
Item No.	Part Number	Description	Qty
1	150-150G	1-1/2" EPDM Gasket	3
2	105-200BRB	2" Manifold x 2" HB	2
3	150-200PLG025	2" Manifold Plug x 1/4" FPT	1
4	105-200TEE	2" Flanged Tee Fitting	1
5	105-FC200	2" Manifold Clamp	3
6	113-06-025025	QC to MPT - 1/4" QC x 1/4" MPT	1
7	350-PS238	Pressure Seal HD Clamp, Size 238 - 1.625" - 2.125" (1-1/4" - 1-1/2" ENF, WBS or AG200 hose)	2
8A	521-05-050150	3 Wire Pressure Sensor (0 - 5 V DC) with 3 pin 150 MP Tower Connector	1
8B	521-05-050100	2 Wire Pressure Sensor (4 - 20 mA out) with 2 pin 150 MP Tower Connector	1
9	396-5407Y1	Remote Pressure Tap Kit Instructions	1

Installation Instructions:

1. Assemble fittings as shown.
2. Route 2" hose and tighten with hose clamps.
3. Plug 2-pin/3-pin pressure sensor connector into pump harnessing.

