

# 396-3813Y1

## Commander Orchard Sprayer Control Operator's Manual

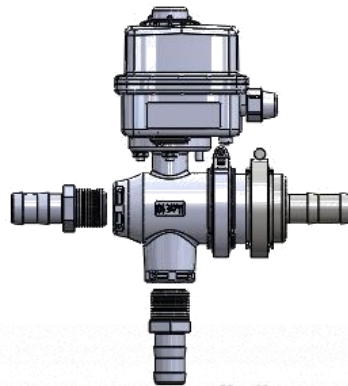

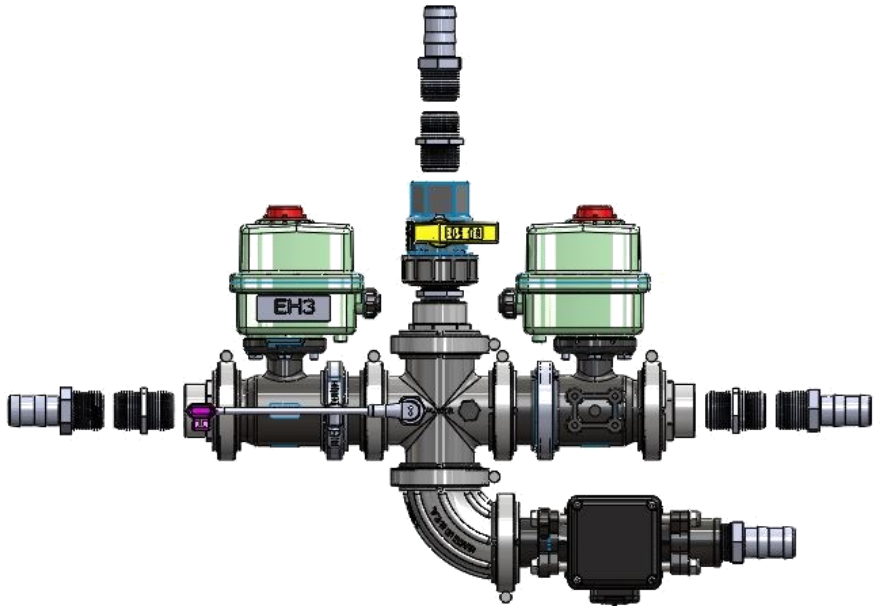

# Table Of Contents

## Introduction

- Commander Sprayer Control Kit Numbers.....2
- Basic Steps to Install your Fertilizer System .....3

A

Introduction

## Components - Liquid

- Plumbing Layout Overview .....4
- Flowmeter, Section Valves, Pressure Sensor .....5
- Commander Servo Valve Kit.....6
- Commander Flowmeter Kit with Section Valves .....7
- Commander Flowmeter Kit (No Section Valves).....8
- Commander Section Valves ONLY Kit.....9

B

Components  
Liquid

## Components - Wiring & Electrical

- Commander II Display and Control Kit Overview, Harness Layout.....10
- Commander Final Harness Drawing .....11

D

Components  
Wiring & Elec.

## Installation Overview

- Installing Servo Control Valve Assembly.....12-13
- Installing flowmeter and Section Valve Assembly .....14-16
- Installing flowmeter with no Section Valves .....17-18
- Installing Commander II Controller in cab .....19
- Installing the Speed Sensor (Astro II GPS or Vansco Radar Sensor).....20-23

E

Installation  
Overview

## Setup & Operation *\*(Use this to get started)\**

- Commander II Console Overview .....24
- Special Cal Setup (SPEC) .....25-26
- Standard Calibration Procedure, (CAL mode) settings .....27
- Initial Tests to Verify Proper Operation (**DO THIS**) .....28
- Special Calibration (Special Cal—SPEC) Procedure and Settings .....29-31
- Commander II Orchard Sprayer console setup summary .....32

F

Setup &  
Operation

## Troubleshooting

- Common Troubleshooting Issues .....33-35
- Distance / Speed Verification Procedure (*Do if using Vansco Radar*) ....35

G

Trouble-  
Shooting

## Maintenance & Parts

- Winterization and Pre-season Service .....36

H

Maintenance  
& Parts



Commander Sprayer Control Kit Numbers

540-01-100100 : Commander Display and Control Kit With Radar

540-01-100200 : Commander Display and Control Kit With GPS

540-02-100200 : Commander Flowmeter Kit with Section Valves

540-02-100300 : Commander Flowmeter Kit (No Section Valves)

540-02-100350 : Commander Section Valves Only Kit

540-02-100100 : Commander Servo Valve Kit



# General Description

## A

### Introduction

You have purchased a Commander Orchard Sprayer Control System for your sprayer. This system will automatically control the application rate in gallons per acre based on feedback from the flowmeter and vehicle speed. In addition, when either the left or right side of the sprayer is turned off, the Commander will reduce the total spray volume so the application rate remains correct.

## Basic Installation Steps

Open the packages and familiarize yourself with the components. See the System Overview Examples on the following pages to see the big picture of how the orchard sprayer control components are installed. Refer to manual sections B, C & D for component information.

1. Mount the servo valve assembly which will receive flow from the pump.
2. Mount the flow meter assembly. If your sprayer already has electric left and right valves, these will remain. If not, the flowmeter assembly will include left and right valves.
3. Mount the Commander II Controller in the tractor cab.
4. Mount the speed sensor on the tractor. In canopied crops, a radar speed sensor will be used. In open crops where the sky is visible a GPS speed sensor will be used. The speed sensor can also be mounted on the sprayer if preferred.
5. Fill system with water, set up Commander II, conduct initial operation and tests per Section F and/or the QuickStart card.

# Commander Plumbing Overview

The following gives an example of a complete Commander II Orchard Sprayer Control System with these components:

## B Components Liquid

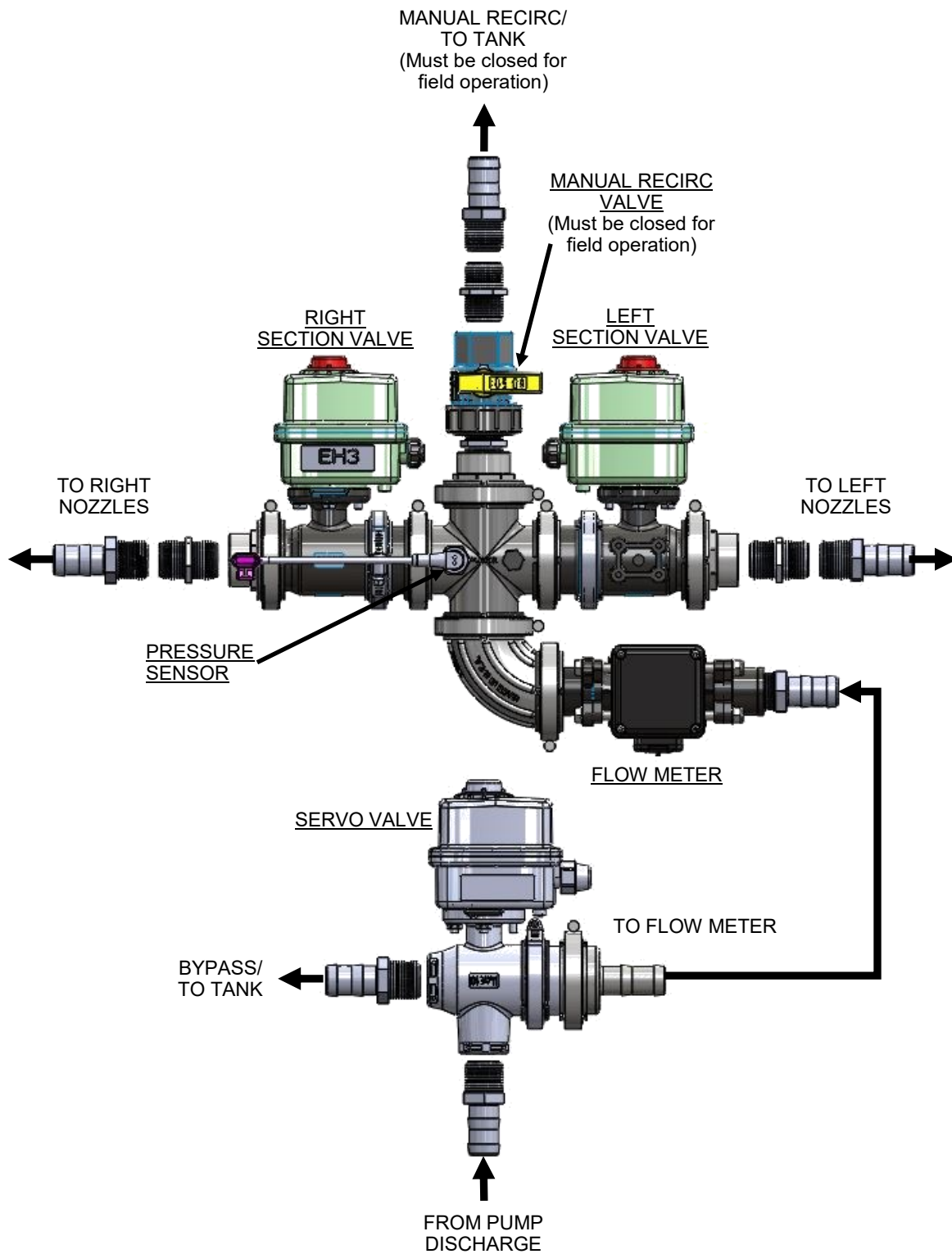

# Electromagnetic Flowmeter

The standard flowmeter for the Orchard Sprayer is 1.3– 26 gpm. See the chart below if using a different sized flowmeter.

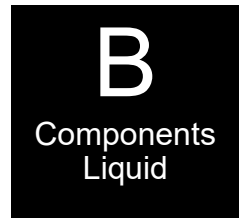

*Before doing any arc welding on the implement, unplug the cable to the flowmeter, or damage to the flowmeter may result.*

*Do not power wash the flowmeter. High pressure spray directed at the back edge of the face plate or at the wire connector may allow water into the flowmeter electronics.*

Electromagnetic flowmeters are superior to traditional turbine flowmeters in two basic ways. First, they have no moving parts. This translates into no wear items or potential for contaminants to jam a spinning turbine. Second, electromagnetic flowmeters detect the flow by electrically measuring the velocity of the liquid, which makes them independent of viscosity or density of the fluid measured. They are extremely accurate using the standard calibration number. SurePoint still recommends you perform a catch test to verify the system is properly installed and configured.

Flowmeter Model (black meter with orange label)	Pulses/Gal	Commander II Flow Cal
0.3-5.0 GPM	3000	6000
0-6 –13 GPM	2000	4000
<b>1.3 - 26 GPM</b>	2000	<b>4000</b>
2.6 - 53 GPM	2000	4000

## Flowmeter Connector Pinout

- 1—Ground
- 2—12v Power
- 3—Flow Signal

*You may need to remove the red guard to reach the pins with a voltmeter probe. Be careful not to break the sides of the red guard.*

# Section Valves

## How section valves work

The valves have a 3-pin weather pack electrical connector. This has a power, ground, and switched wire. The power measured to ground should have 12 volts when the controller is on. The switched wire will have 12 volts to turn the valve on, and 0 volts to turn the valve off.

**Wiring Connector:**  
Pin A—Red, 12 Volts +  
Pin B—Black, Ground -  
Pin C—White, Signal  
12V=on ; 0V=off

# Pressure Sensor

The Commander Orchard Sprayer comes equipped with a 400 psi pressure sensor to work with the Commander II controller. This sensor is a 2 wire (4-20 mA) type sensor for compatibility with the Commander II. The sensor has a 1/4" MPT fitting.

The Commander II display will show the system pressure on the in cab controller. **The pressure reading is only for informational purposes and is NOT used in the flow control process.** Flow control uses the flowmeter feedback only.

**See Section G of this manual for more troubleshooting tips.**



# Commander Sprayer Plumbing Kits

## 540-02-100100 : Commander Servo Valve Kit

# B

Components  
Liquid

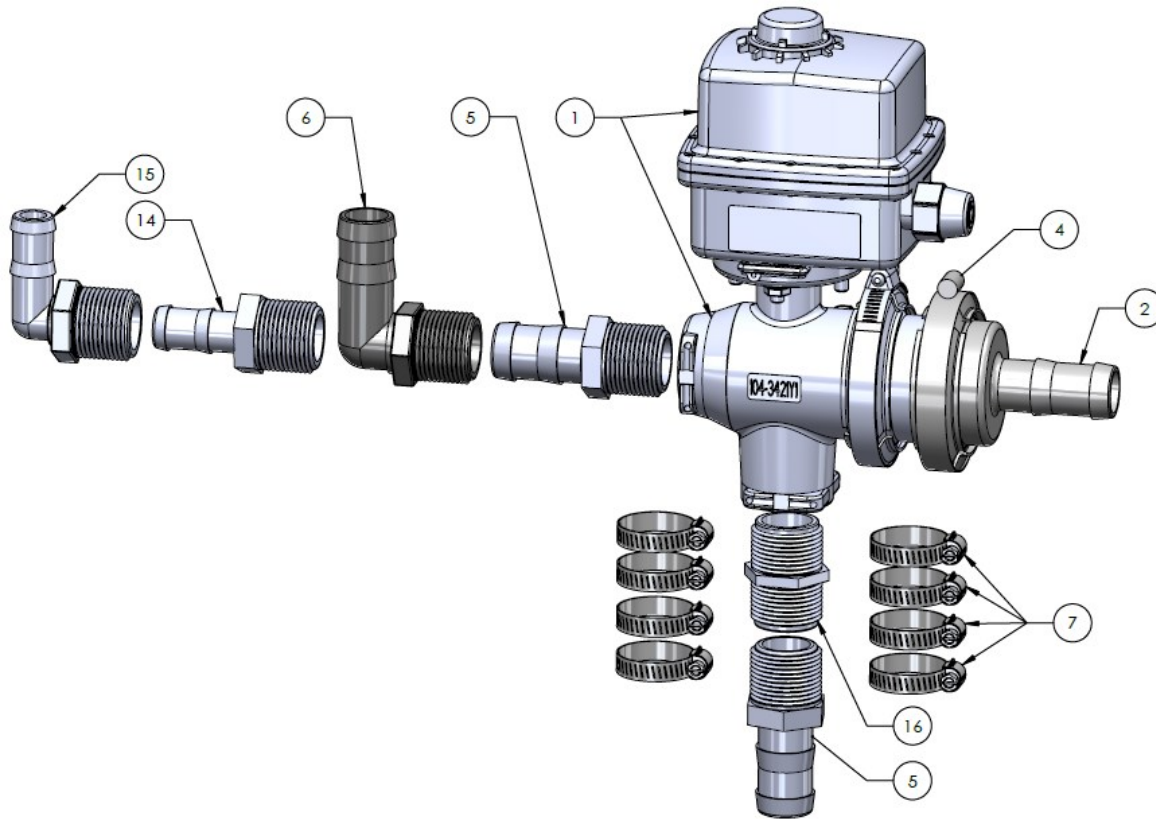

ITEM NO.	PART NUMBER	DESCRIPTION	QTY.
1	103-3714Y1	1" 3 Way Servo Valve with M200 Flange - 4PIN WP - 5S @ 180	1
2	105-200100BRB	2" Flange x 1" Hose Barb	1
3	105-150G	1 1/2" EPDM Gasket	1
4	105-FC200	2" Manifold Clamp	1
5	101-100100	1" MPT x 1" HB	2
6	101-100100-90	1" MPT x 1" HB - 90 Degree	1
7	350-1608	1" Hose Clamp	8
8	280-100-AG200	6 Feet - 1" AG200 Hose	6
9	399-RSTB-2	Rectorseal Tru Blue - 2 oz Tube	1
10		Label 'To Flow Meter'	1
11	300-040012-SS	1/4" x 3/4" Hex Head Bolt-SS	4
12	330-04	1/4" Flat Washer	4
13	331-04	1/4" Lock Washer	4
14	101-100075	1" MPT x 3/4" HB	1
15	101-100075-90	1" MPT x 3/4" HB - 90 Degree	1
16	100-100NIP-SH	1" Short Nipple	1



# Commander Sprayer Plumbing Kits

540-02-100200 : Commander Flowmeter Kit with Section Valves

# B

Components  
Liquid

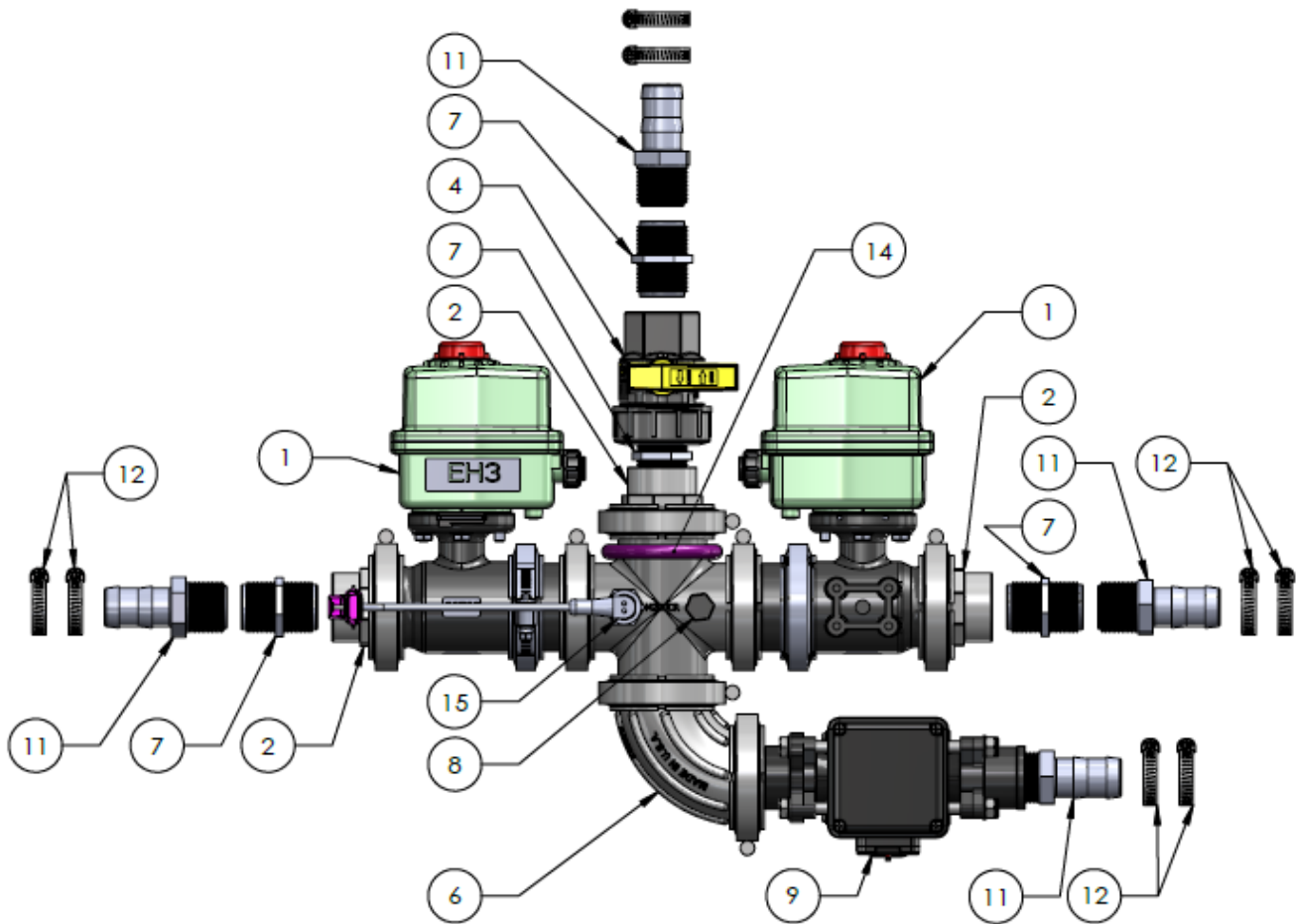

ITEM NO.	PART NUMBER	DESCRIPTION	QTY.
1	103-2415Y1	1" Rinse Valve	2
2	105-200PLG100	2" Manifold Plug x 1" FPT	3
3	105-150G	1 1/2" EPDM Gasket	7
4	102-100SUBV-H	1" Union Valve - FNPT	1
5	105-FC200	2" Manifold Clamp	7
6	105-200SWP90	2" Manifold Sweep - 90 Degree	1
7	100-100NIP-SH	1" Short Nipple	4
8	100-025PLUG	1/4" Pipe Plug	1
9	204-01-46211CUF03	Electro Magnetic Flow meter 1.3 - 26 GPM Non-visual	1
10	125-463F200	463 Series Female Flange x 2" Full Port Manifold (EM Flow Meter Discharge Fitting)	1
11	101-100100	1" MPT x 1" HB	4
12	350-1608	1" Hose Clamp	8
13	105-200CR-025025	2" Manifold Cross	1
14	302-UB202	M200 U-Bolt Assembly - 2 SS U-Bolts, 4 SS Lock Washers and Nuts	1
15	521-05-050450	400 PSI 2 wire pressure sensor (4 - 20 mA out) with 2 pin 150 MP Tower connector	1

# Commander Sprayer Plumbing Kits

## 540-02-100300 : Commander Flowmeter Kit (No Section Valves)

# B

Components  
Liquid

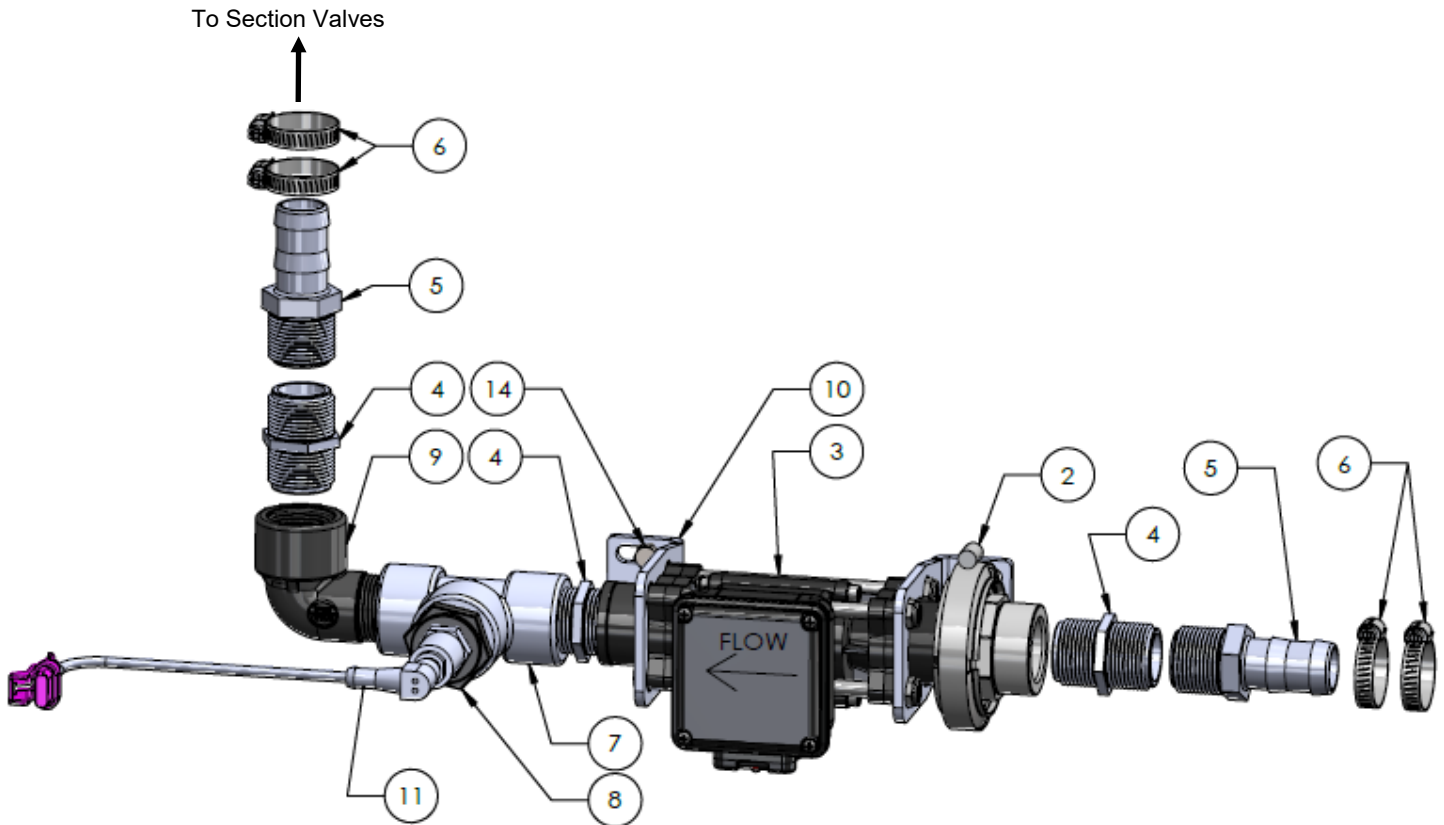

ITEM NO.	PART NUMBER	DESCRIPTION	QTY.
1	105-150G	1 1/2" EPDM Gasket	1
2	105-FC200	2" Manifold Clamp	1
3	204-01-46211CUF03	Electro Magnetic Flow meter 1.3 - 26 GPM Non-visual	1
4	100-100NIP-SH	1" Short Nipple	3
5	101-100100	1" MPT x 1" HB	2
6	350-1608	1" Hose Clamp	4
7	100-100TEE	1" Pipe Tee	1
8	100-100025RB	1" MPT x 1/4" FPT Reducer Bushing	1
9	100-100100SL-90	1" Street Elbow - 90 Degree	1
10	400-3826Y1	SS Flowmeter Mounting Bracket	2
11	521-05-050450	400 PSI 2 wire pressure sensor (4 - 20 mA out) with 2 pin 150 MP Tower connector	1
12	125-463F200	463 Series Female Flange x 2" Full Port Manifold (EM Flow Meter Discharge Fitting)	1
13	105-200PLG100	2" Manifold Plug x 1" FPT	1
14	300-040100-5	1/4" x 1" Hex Head Bolt-G5	4
15	323-04	1/4" Flange Nut	4

# Commander Sprayer Plumbing Kits

540-02-100350 : Commander Section Valves ONLY Kit

**B**

Components  
Liquid

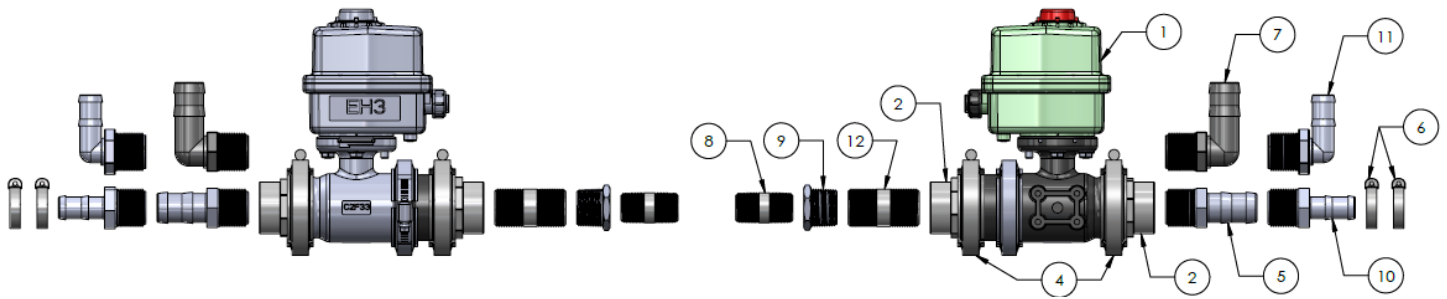

ITEM NO.	PART NUMBER	DESCRIPTION	QTY.
1	103-2415Y1	1" Rinse Valve	2
2	105-200PLG100	2" Manifold Plug x 1" FPT	4
3	105-150G	1 1/2" EPDM Gasket	4
4	105-FC200	2" Manifold Clamp	4
5	101-100100	1" MPT x 1" HB	2
6	350-1608	1" Hose Clamp	4
7	101-100100-90	1" MPT x 1" HB - 90 Degree	2
8	140-075NIP-2	3/4" x 2" Nipple - SS	6
9	140-100075RB	1" x 3/4" Reducer Bushing - SS	2
10	101-100075	1" MPT x 3/4" HB	2
11	101-100075-90	1" MPT x 3/4" HB - 90 Degree	2
12	140-100NIP-2.5	1" x 2.5" Nipple - SS	2

# Commander II Display and Control Kit Overview

**D**  
Components  
Wiring & Elec.

Kit Numbers...

**540-01-100100** : Commander Display and Control Kit With Radar

**540-01-100200** : Commander Display and Control Kit With GPS

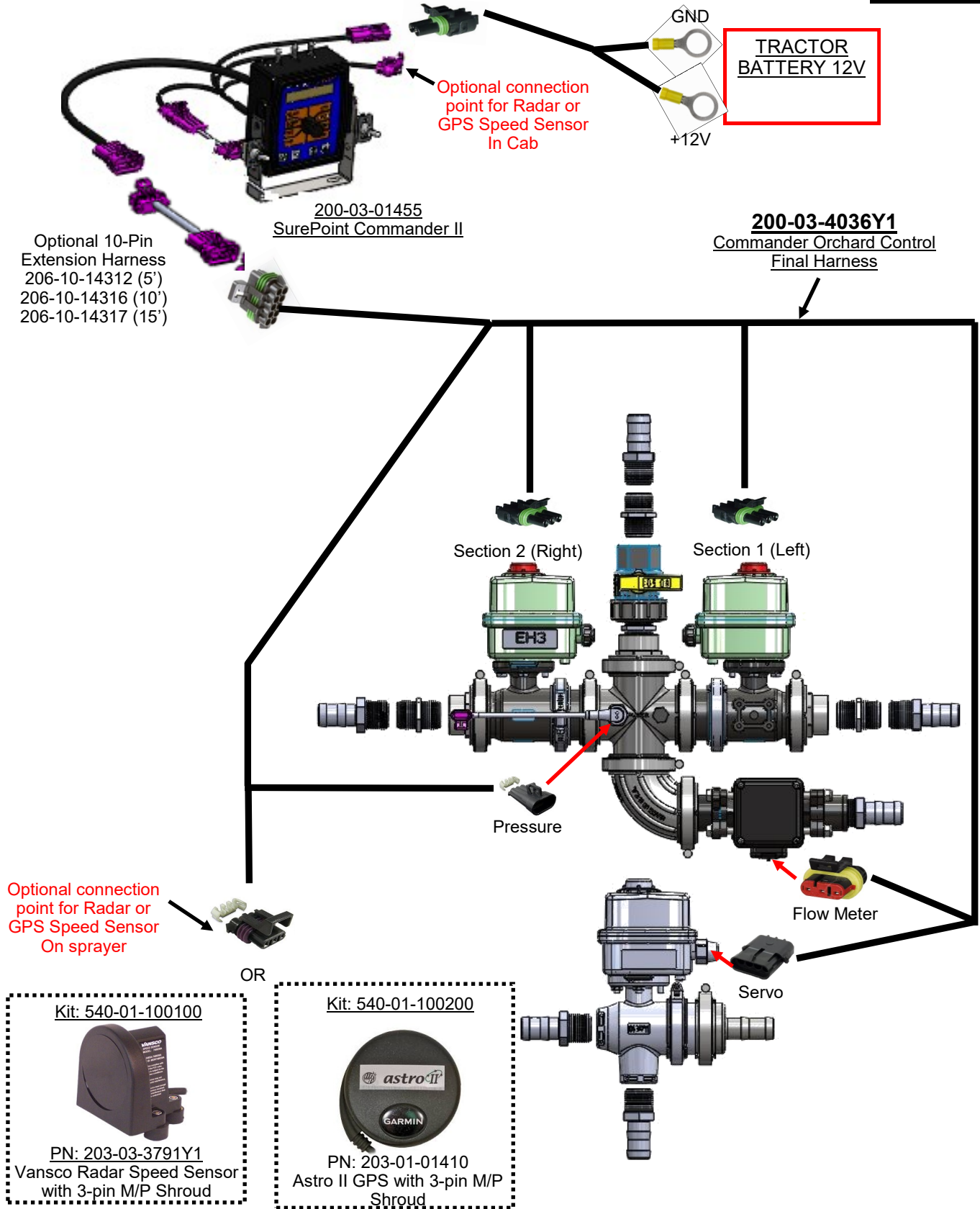

# Commander Display and Control Kit

200-03-4036Y1 : Commander Final Harness (Servo, Flow, Pres, Section 1-3, Spd)

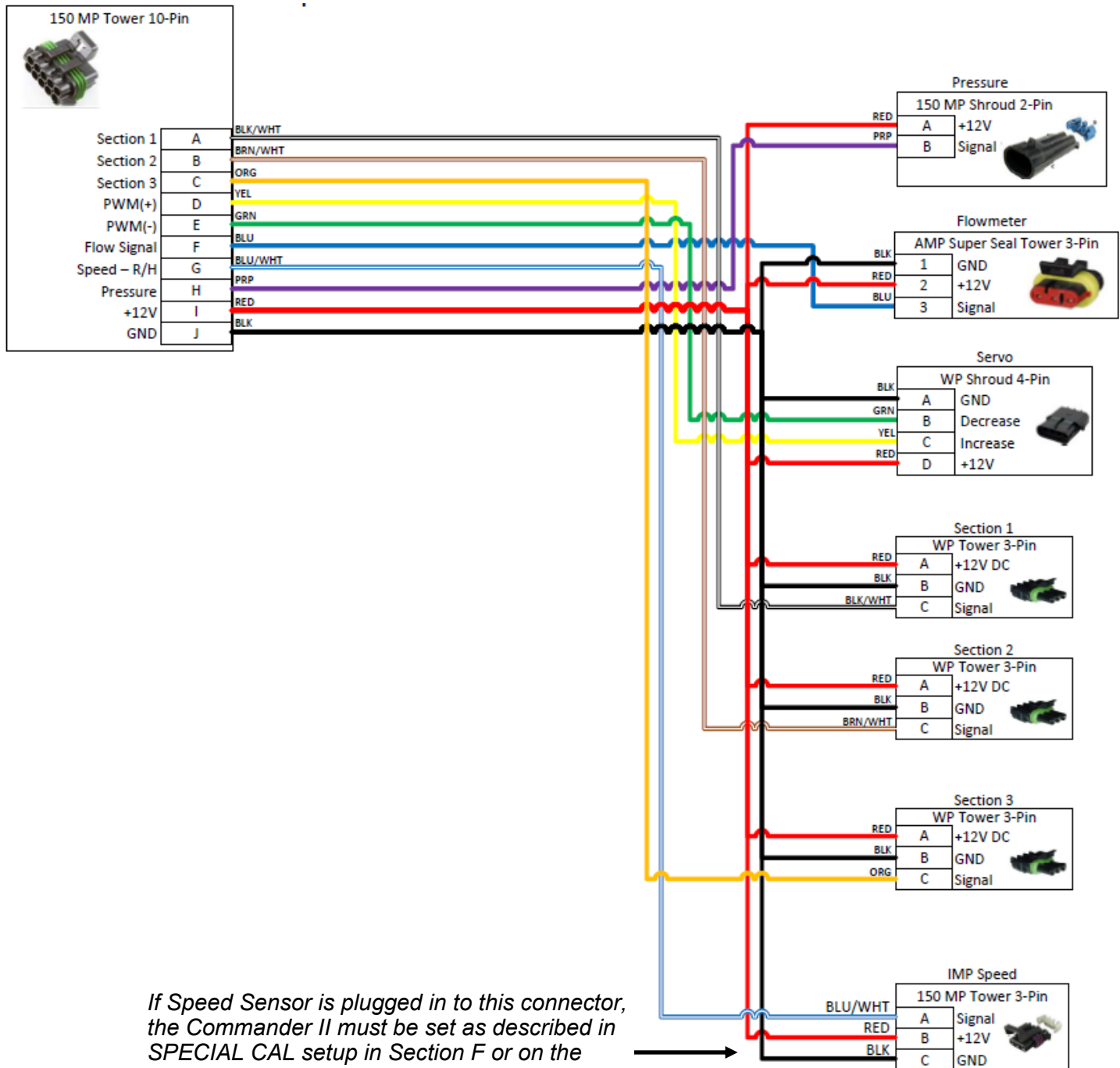
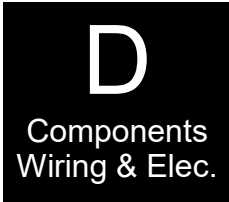

*If Speed Sensor is plugged in to this connector, the Commander II must be set as described in SPECIAL CAL setup in Section F or on the QuickStart card.*

# Step 1 Install the servo valve assembly

You will need to install both the servo valve and the flowmeter and section valve assembly on the sprayer. Before you mount the servo valve assembly make sure to plan out how both assemblies will mount and connect together with hoses.

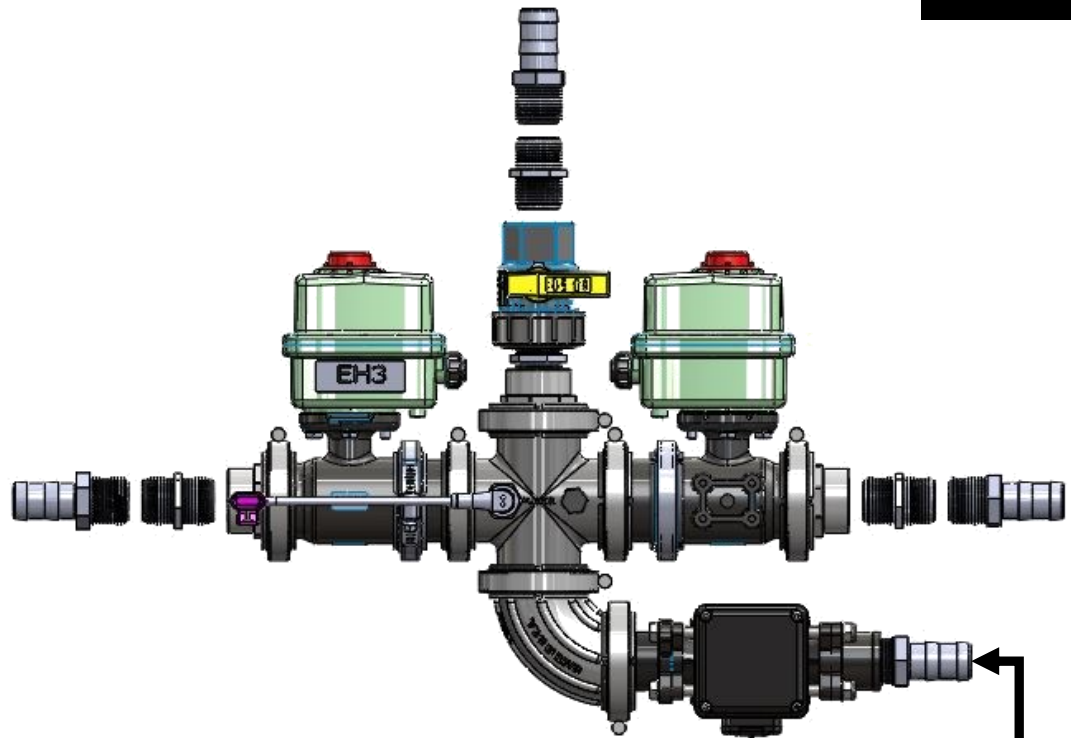

Plumb this line back into tank or an existing bypass line that runs back to tank. Fitting options include 1" or 3/4" hose barbs

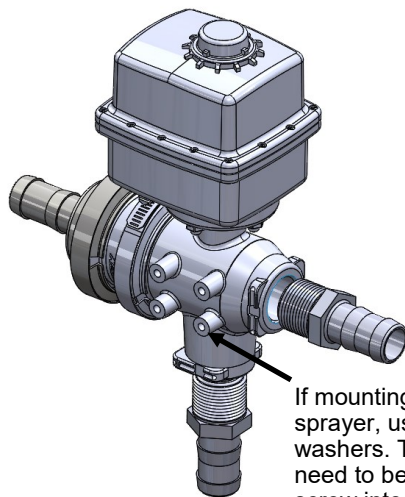

If mounting servo to support bracket or to sprayer, use the supplied 1/4" bolts and lock washers. The mount holes on the servo will need to be tapped (1/4") to allow the bolts to screw into the holes.

You may also be able to mount servo in line of rigid piping for enough support and not need to mount with 1/4" bolts. See next page for examples on mounting Servo...

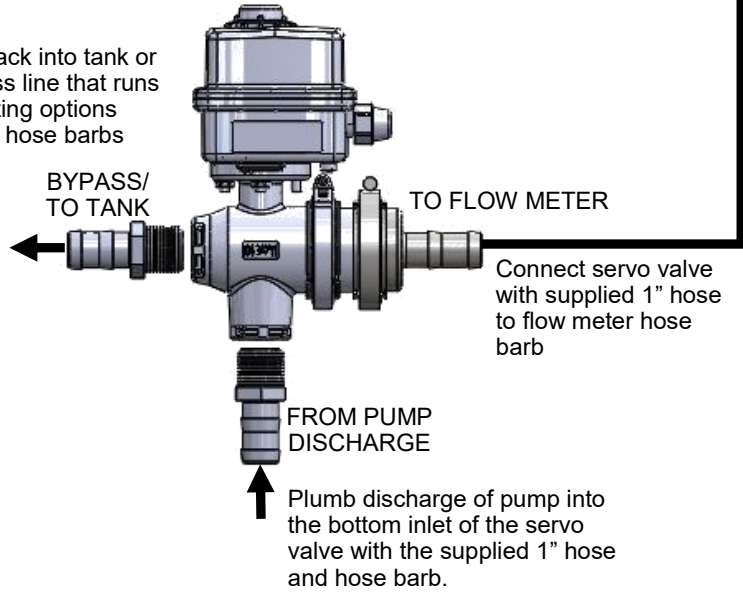



# Step 1 Install the servo valve assembly cont'd...

Servo Valve Mounting Examples...

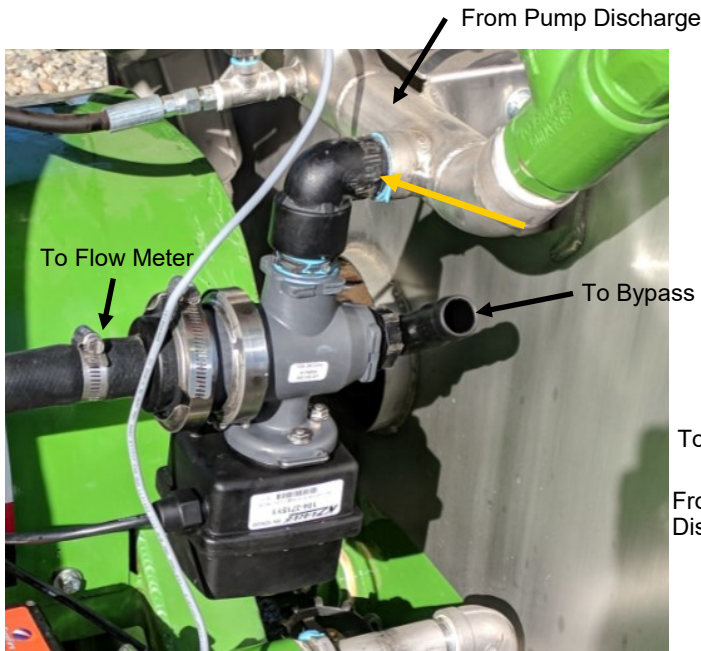

D&M SF36

Servo mounted to rigid pipe fittings for support and did not use mount holes on Servo

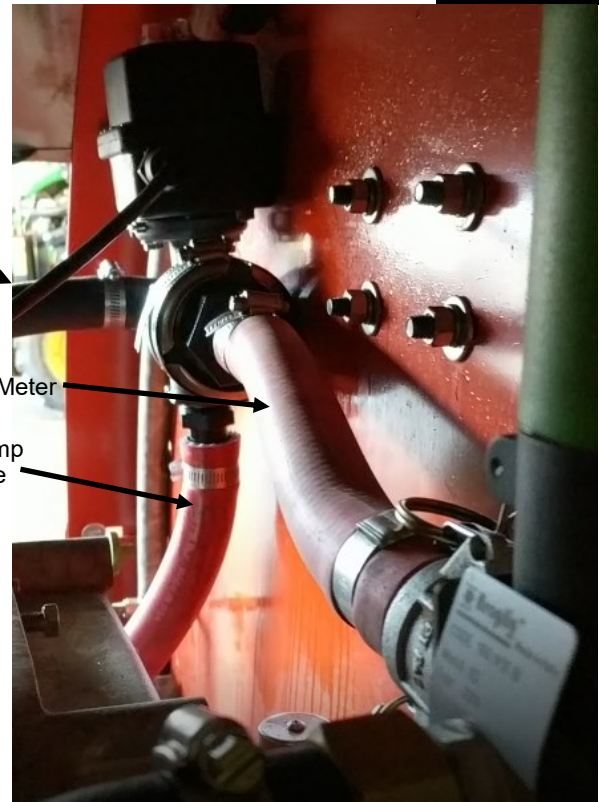

Rears PB633ST

Servo mounted to back wall of Sprayer by drilling holes and using the supplied 1/4" Bolts.

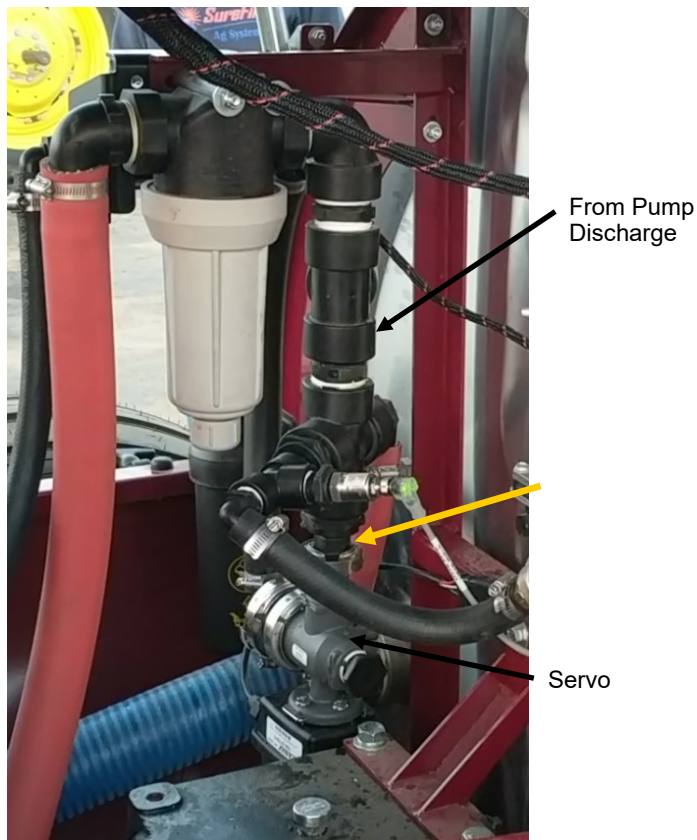

Lectro Blast 2260

Servo mounted to rigid pipe fittings for support and did not use mount holes on Servo



## Step 2 Install the flowmeter/section valve assembly

You will need to install both the servo valve and the flowmeter and section valve assembly on the sprayer. Before you mount the servo valve assembly make sure to plan out how both assemblies will mount and connect together with hoses.

# E

Installation  
Instructions

540-02-100200 : Commander Flowmeter Kit with Section Valves

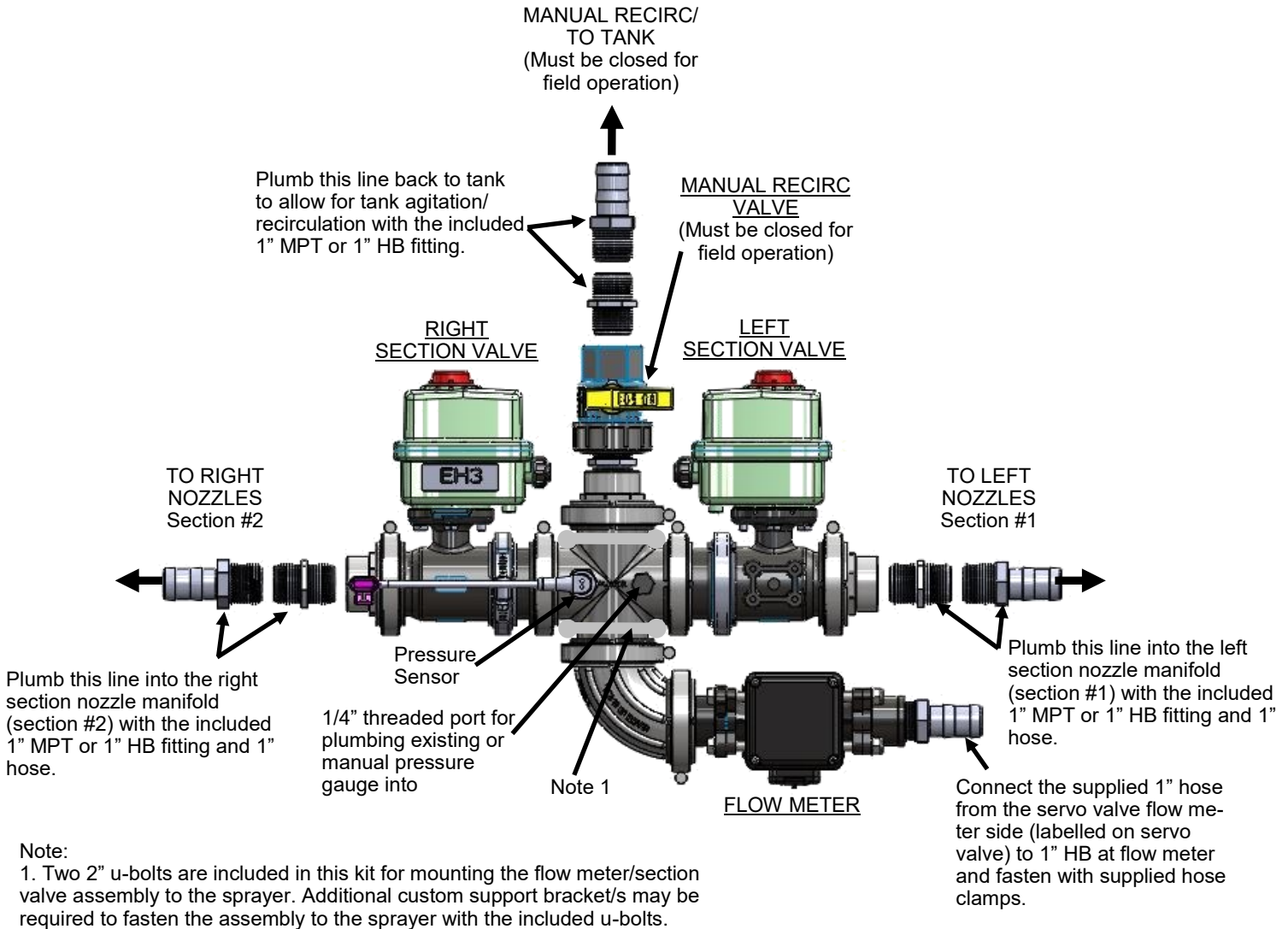

## Step 2 Install the flowmeter/section valve assembly

Commander Flowmeter Kit with Section Valves installation example...

# E

Installation  
Instructions

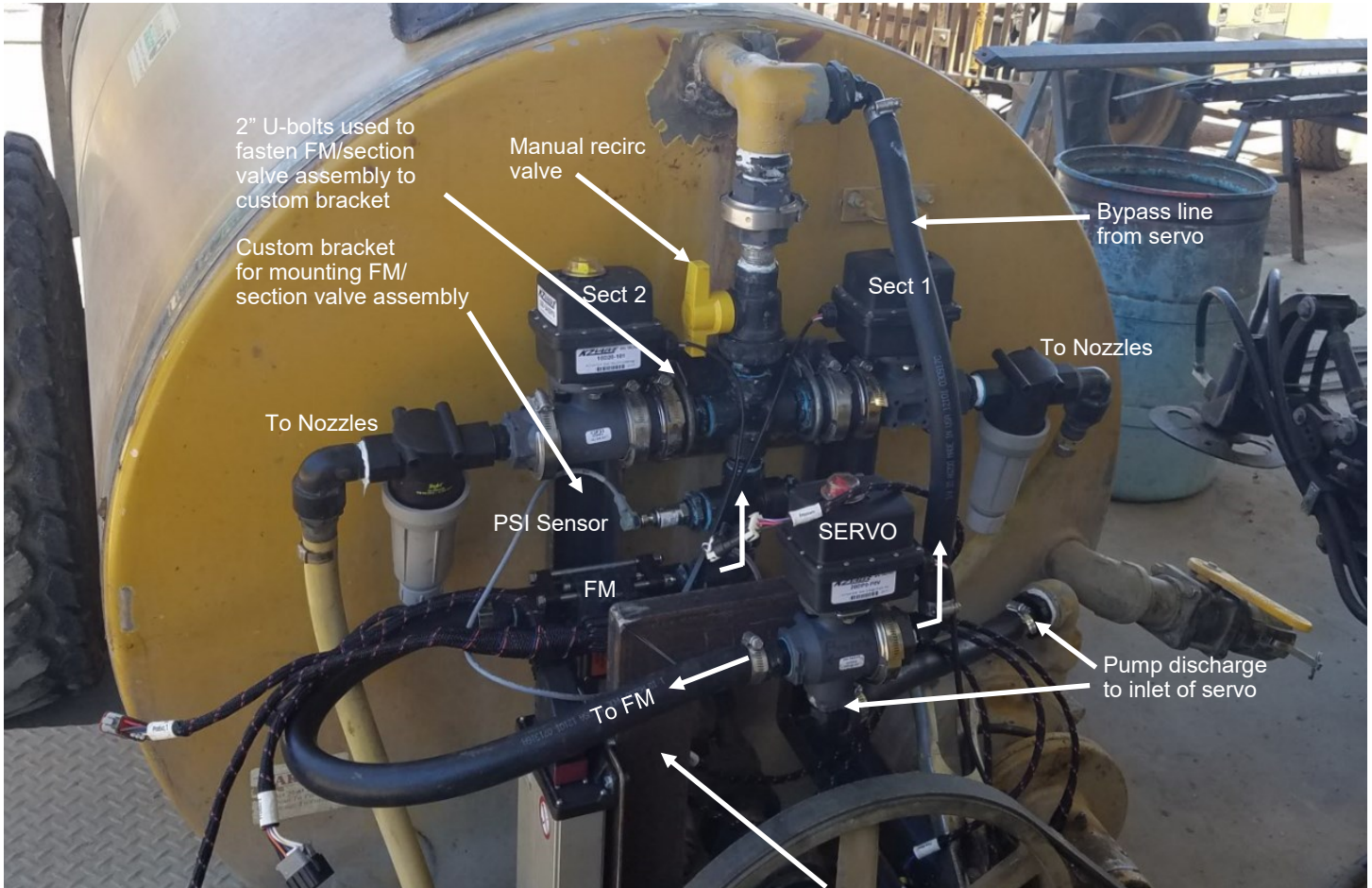

Custom bracket for servo valve

## Step 2 Install the flowmeter/section valve assembly

Commander Flowmeter Kit with Section Valves installation example...

# E

Installation  
Instructions





## Step 2 Install the flowmeter without section valves

You will need to install both the servo valve and the flowmeter and section valve assembly on the sprayer. Before you mount the servo valve assembly make sure to plan out how both assemblies will mount and connect together with hoses.

# E

Installation  
Instructions

### 540-02-100300 : Commander Flowmeter Kit (No Section Valves)

Plumb discharge of flow meter into line prior to section valves using the supplied 1" MPT Nipple or 1" HB fitting.

Flow meter support brackets w/ 1/4" hardware if needed. Plumbing the flow meter assembly into rigid piping for support may alleviate the need for using brackets. See next page for installation examples

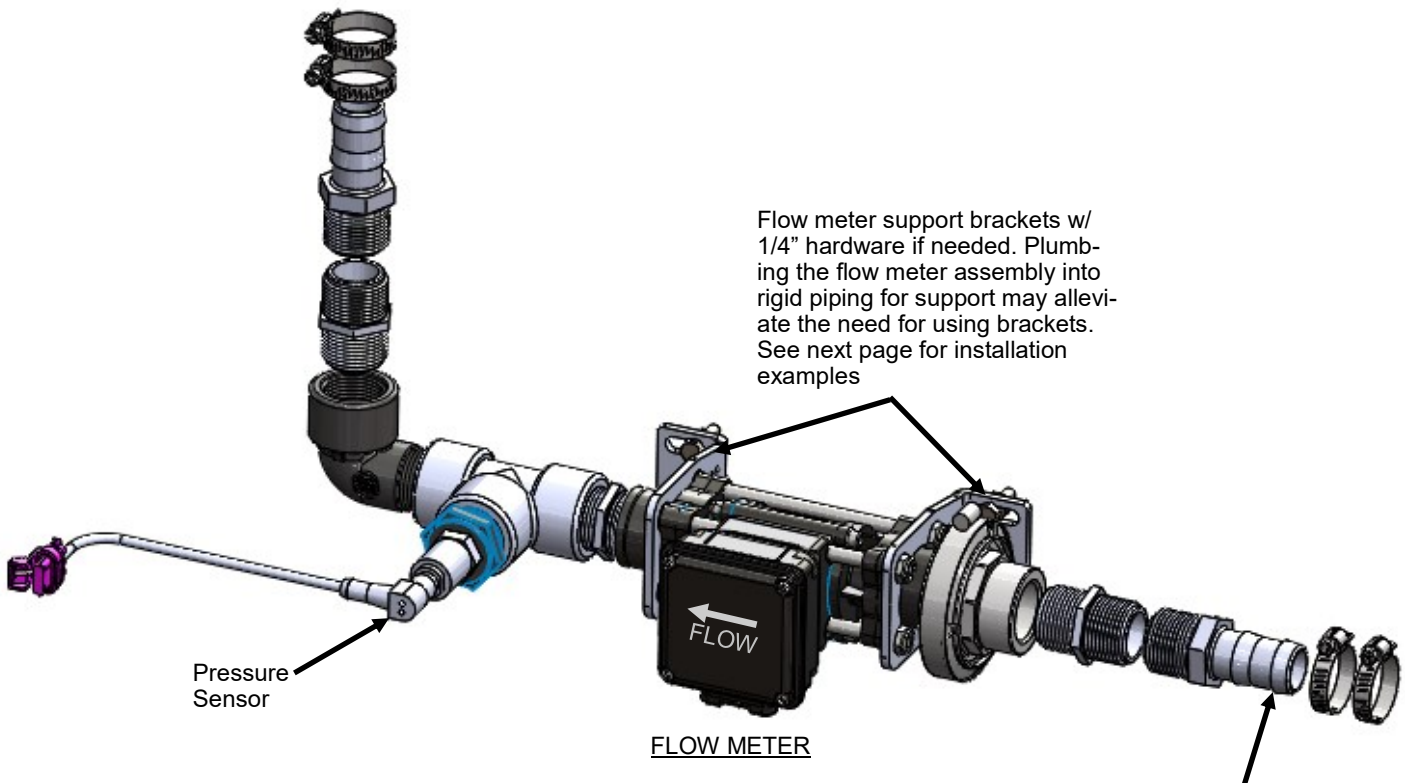

Connect the supplied 1" hose from the servo valve flow meter side (labelled on servo valve) to 1" HB at flow meter and fasten with supplied hose clamps. Optional 1" pipe nipple supplied if needed.

## Step 2 Install the flowmeter without section valves



Flow Meter Installation Examples...

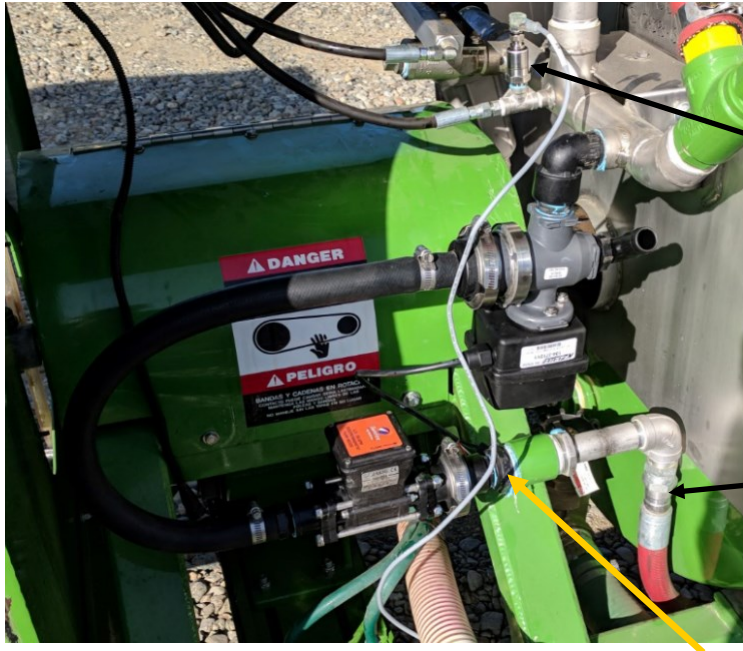

Pressure sensor mounted in existing manual pressure gauge position

To nozzle manifold or section valves towards the rear of sprayer

D&M SF36

Flow meter mounted to rigid pipe fittings for support and did not need support brackets

To section valve manifold



1" Tee and pressure sensor mounted prior to flow meter to accommodate space constraints

Rears PB633ST

Flow meter mounted vertically to rigid pipe fittings for support and did not need support brackets

## Step 4 Install the Commander II Controller in the cab

# E

Installation  
Instructions

The display will mount in the cab for the operator to control the sprayer with.



Included in the Display and Control Kit 540-01-100200 is the Ram 1" Ball Mount for mounting the Commander display to in your tractor cab. Install in a visible and accessible location inside the cab using size #10 screws. The screws that are needed to mount the display to the Ram Mount are included in the box that the display comes in.

If space allows, you can mount the Commander II Controller without the Ram Mount.

## Step 5 Install the speed sensor on the tractor

The rate controller needs a speed input. In a full canopied crop a radar speed sensor is used. If the sky is visible a GPS speed sensor will be used.

# E

Installation  
Instructions

See below for radar installation instructions...



## Reference Guide Vansco Radar Speed Sensor Installation

### COMPONENTS:

- (1) Vansco Radar Speed Sensor
  - (1) Vansco Radar Mount Kit
- KIT INCLUDES:**
- (1) Mount bracket (M-T P/N #17281)
  - (3) M6 x 12mm screw (M-T P/N #17377)
  - (3) 1/4" lock washer (M-T P/N # 10057)
  - (5) 14" nylon tie (M-T P/N #10045)
  - (1) Adapter cable for new Micro-Trak products (only included with radar P/N 01527)



The Vansco radar is typically installed at a height of 2 feet (0.6 m), but can be installed up to 4 feet (1.2 m) above the ground or above the top of the crop. The sensor can be mounted facing forward or rearward, and positioned so that it has a clear view of the ground.

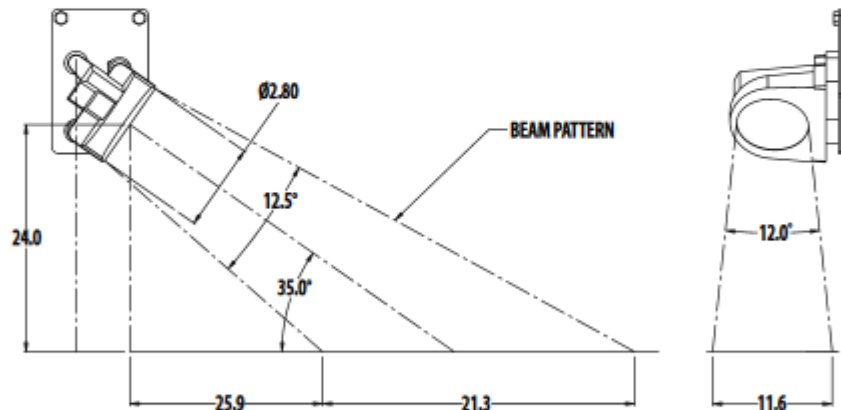

### BRACKET INSTALLATION AND MOUNTING:

- Use the mounting bracket (M-T P/N # 17281) supplied, or other suitable method.
- Install the mount bracket (M-T P/N # 17281) to the Vansco radar with the M6 x 12mm screws (M-T P/N # 17377) and 1/4" lock washers (M-T P/N # 10057) supplied. *See photo at right.*



**NOTE:** For proper operation, the radar face must be in-line with the direction of travel; the radar face must NOT point upwards.

Note: Either the radar or GPS speed sensors can be mounted on the sprayer if preferred. A speed connect- or is provided on the wiring harness. **If the radar or GPS Speed Sensor is mounted on the sprayer, the Remote RUN/HOLD setting in Special CAL 2 must be set to Speed** (instructions are in Section F and in the QuickStart section).



# Step 5 Install the speed sensor on the tractor

# E

Installation  
Instructions



## Reference Guide Vansco Radar Speed Sensor Installation (cont.)

In order to check that your installation location will allow the Vansco radar to be mounted at the proper angle, and free from interference, attach the mount bracket (M-T P/N # 17281). Hold the temporarily-secured radar in the desired mounting position. Make sure that the radar can be tilted to the recommended angle. See "General Mounting Information".

Once a suitable mounting position has been determined, attach the mounting bracket (M-T P/N # 17281) in the desired position.

Securely tighten the mounting bracket (M-T P/N # 17281) to vehicle.

**NOTE:** Some possible mounting locations are shown below.



Correct mounting positions



Incorrect mounting positions

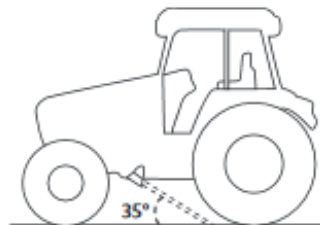

### CALIBRATION:

If you are using a Micro-Trak console, start with a distance calibration (CIRC) of 0.151 and perform "Fine-tuning Speed/Distance Calibration" outlined in the console's reference manual.

Note: Either the radar or GPS speed sensors can be mounted on the sprayer if preferred. A speed connect- or is provided on the wiring harness. **If the radar or GPS Speed Sensor is mounted on the sprayer, the Remote RUN/HOLD setting in Special CAL 2 must be set to Speed (instructions are in Section F and in the QuickStart section).**

# Step 5 Install the speed sensor on the tractor

# E

Installation  
Instructions



## Reference Guide Vansco Radar Speed Sensor Troubleshooting

Many problems are the result of mistakes in installation or operation. Before returning any parts for service, carefully check your installation and review the operating instructions. If you have determined that the Vansco radar unit needs service, or for warranty issues, please call one of the following certified Ag Express locations:

Grand Island, NE (308) 381-2905	Des Moines, IA (515) 289-2746	Sulphur Springs, IN (765) 533-4809
------------------------------------	----------------------------------	---------------------------------------

**Be sure to ask about any associated charges.**

### TIPS FOR TROUBLESHOOTING

1. Disconnect the radar adapter cable from the console harness.
2. Check for 12 VDC between pins B and C of the main harness connector (yellow tie). If not present, console or harness may be defective.
3. Using a jumper wire (paper clip bent into a "U"), rapidly short together positions A and C of the main harness speed connector (yellow tie) several times. The console should respond with some MPH reading. If not, the console or harness may be defective.
4. Reconnect the radar adapter cable to the main harness speed connection (yellow tie).
5. Disconnect the radar from the radar adapter cable.
6. Check for 12 VDC between pins 1 and 3 of the radar adapter connector (round 4-pin — see diagram below). If it is not present but was present in step 2, the radar adapter cable may be defective.
7. Using a jumper wire (paper clip bent into a "U"), rapidly short together positions 2 and 3 of the radar connector (round 4-pin) several times. The console should respond with some MPH reading. If not, but had a reading in step 3, the radar adapter cable may be defective.
8. If system passes all above tests, the radar may be defective.



### CARE AND MAINTENANCE:

1. The Vansco radar's case is watertight under normal weather conditions and washing. However, do not subject the Vansco Radar to steam or pressure cleaning.
2. When cleaning is desired, use a mild detergent and low pressure water.
3. Nicks or cuts in cable insulation should be immediately sealed or repaired to prevent corrosion to the wire or short circuits.
4. If an arc welder or any other source of high voltage will be used on the tractor or implement, disconnect all ground and power wires to prevent damage to the electronics.

## Step 5 Install the speed sensor on the tractor

The rate controller needs a speed input. If the sky is visible a GPS speed sensor will be used.

# E

Installation  
Instructions

See below for GPS installation instructions...

### Kit: 540-01-100200



PN: 203-01-01410  
Astro II GPS with 3-pin M/P  
Shroud

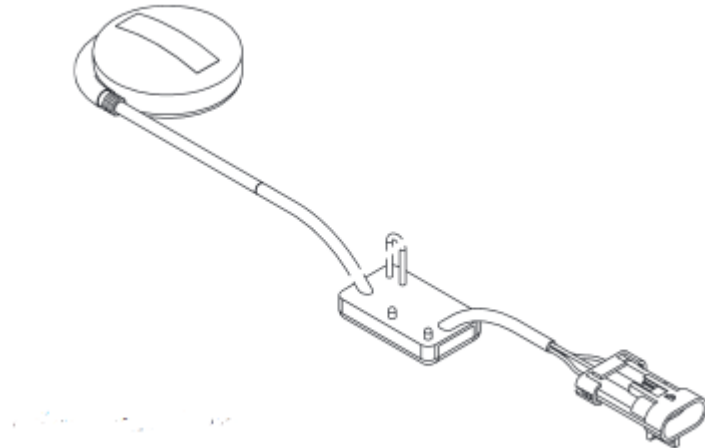

#### Step 1:

\*If you want to mount the sensor on the tractor, connect the sensor to the Commander II connector with a yellow zip tie around it (150 MP Shroud 3-Pin).

\*If you want to mount the sensor on the sprayer, connect the sensor to the 200-03-4036Y1 Control Harness on the sprayer. The connector on the harness is labelled 'Imp Speed'. **If the GPS Speed Sensor is mounted on the sprayer, the Remote RUN/HOLD setting in Special CAL 2 must be set to Speed.**

Step 2: The base of the sensor is magnetic. Place the sensor on the top of the cab if installed on the tractor. Place the sensor on top of the sprayer if installed on the sprayer.

Step 3: On the Commander II controller, verify that the Speed CAL is set at 0.189 when using the Astro II Speed sensor.

See page 5 for harnessing connection locations...

# Commander II Console Functions

This page shows an overview of the various features of the Commander II. The following pages will have specific instructions on how to set up each feature for the Commander Orchard Sprayer.

# F

Setup & Operation

## In Field Operating Instructions

**VOLUME:** Displays total gallons (liters) of liquid applied. Can be reset to 0 by holding the reset button.

**3 SECTION SWITCHES:** Turns application on or for each section. If not dividing implement into sections, use Section 1 switch only.

**AREA:** Displays the area of coverage by the equipment in acres (hectares). May be reset.

**VOLUME/MINUTE:** Displays gallons (liters) of liquid applied per minute. Use this to read instant flow in GPM.

**DISTANCE:** Displays the distance traveled in feet (meters). May be reset.

**TANK:** Displays gallons (liters) of liquid remaining

**PRESSURE:** Displays the liquid pressure at the location of the optional pressure sensor. In addition to displaying Pressure the console will warn the operator with HiPSI (High Pressure) message when the input pressure exceeds the limit pressure (set in Special Cal)

**RATE:** Displays application rate GPA(LPH)

**SPEED:** Displays ground speed in miles per hour (Kilometers per hour).

**ON/OFF:** Commander II power switch. When the console is turned on (except when starting in "SPECIAL" CALIBRATE) the data display will show the **Number of Hours** it has operated for one second, followed by the **Software Part Number (45124)** and the **Software Revision (rP X)** for 1.5 seconds each. Then it will display the **Control Mode (P-FLO or S-FLO)** for 1.5 seconds.

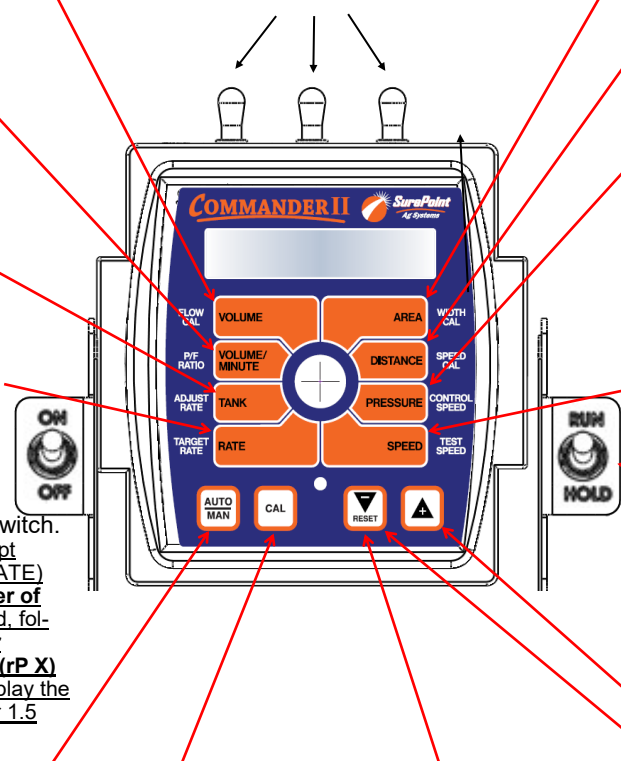

**AUTO/MAN:** Key which changes operation from automatic control to manual.

**CAL:** This key is used to enter & exit calibration mode.

**RESET/ - :** When not in CAL, clears the selected counter when held for two seconds.

**+ & - :** Plus & Minus keys are used to increase and decrease values

## Five Steps for Commander II Setup for Orchard Sprayer Systems

See the following pages for instructions on each step:

1. Commander II Special Cal Quick Setup
2. Standard Calibration settings
3. Initial Operation in Manual Mode
4. Test Speed Operation in Automatic Mode
5. Speed Signal Verification & Field Operation

# Commander II Special Cal Quick Setup

## Step 1

**F**  
Setup &  
Operation

The Commander II must be set up to run the Orchard Sprayer by entering some values in the SPECIAL CAL (SPEC) mode. Follow the steps below to set up the Commander II for your operation.

*Notice that Step 10 must be done if you are using a speed sensor located on the sprayer that is plugged into the connector on the final pump harness.*

1. Power off Commander II.
2. Enter **Special Cal** by holding both the AUTO/MAN and the CAL button down while turning on the power switch.
3. You should see “SPEC” on the screen, if not, repeat steps one and two.
4. Ensure “1” displays to indicate Page 1 in Special Cal. Press CAL to change if necessary.
5. Turn dial to point at **AREA**, Select “HS-E” for Orchard Sprayer with Servo control (and English units). (*Press the UP or DOWN arrow to change selection.*)
6. Turn dial to **SPEED**. Select InLin(e).
7. Press **CAL** to go to Page 2.
8. Turn dial to **SPEED**. Hold + button to set **Full Scale Pressure** to **400**.
9. Turn dial to **AREA**. Set **MAX PRESSURE** to **250**.
10. (*Do this step if Radar or GPS Speed Sensor is located on the sprayer and is plugged into the final pump harness. Skip this step if speed sensor is plugged into connector behind the Commander II.*) Turn dial to **RATE**. Set to **SPEED**.
11. Save changes by holding CAL button until red light goes out (about 3 seconds).

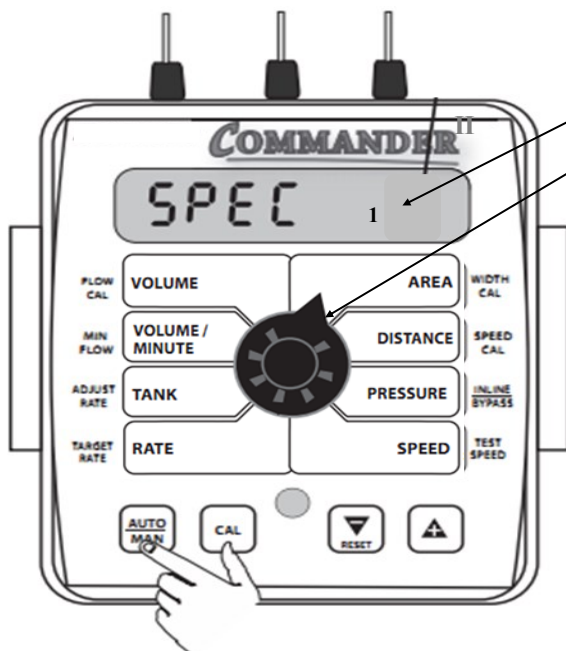

This number tells you which special CAL screen you are on. Pressing the CAL button will change this number. Quick Setup begins on **Page 1**, with dial turned to **AREA**.

Select “**HS-E**” for the orchard sprayer with a Servo control valve and English units (gallons and acres, etc...).

Follow instructions printed above.



### Special CAL Page 1 and Page 2 Typical Settings for Commander Orchard Sprayer Controller:

To see and/or adjust Special Cal settings:

1. Power off Commander II.
2. Enter **Special Cal** by holding both the AUTO/MAN and CAL buttons down while turning on the Power switch.
3. You should see "SPEC" on the screen as the unit comes on. If not, repeat steps 1 and 2.
4. To save any changes, hold the CAL button until the red light goes out.

#### Special CAL 1 Settings

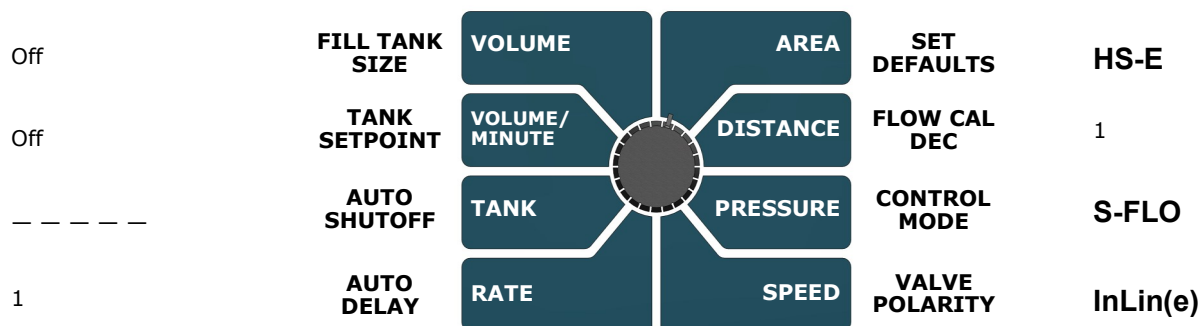

### Special CAL Page 2 Typical Settings for Commander Orchard Sprayer Controller:

#### Special CAL 2 Settings

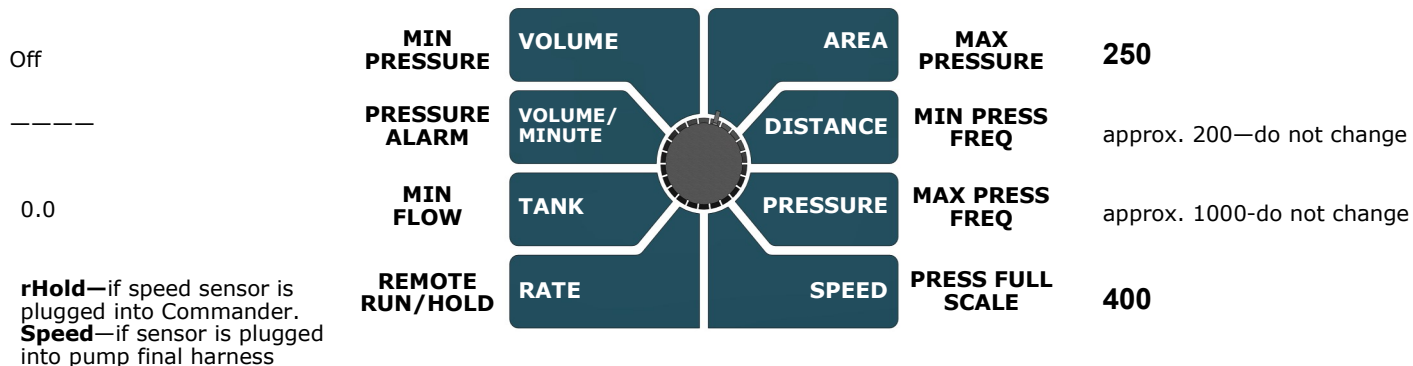

# Standard Calibration Procedure:

## Step 2



1. Press CAL key for one (1) second to enter calibration mode.
2. Red light will be on steady and CAL will be displayed in CAL mode.
3. Turn the dial to the items listed below and set as instructed.
4. Turn dial to **VOLUME**. This is the flowmeter calibration number. It should be the number of pulses per gallon for the flowmeter multiplied by 2. (On the SurePoint 1.3—26 gpm electromagnetic flowmeter, this will be set at **4000**.)
5. Turn dial to **AREA**. Turn on **Boom 1** (top left switch). Use the (+) or (-) button to set the width (in inches) of the left side of the sprayer coverage area. *(If you do not have left and right section control valves, this would be the spray width of the entire sprayer.)*
6. Turn Boom 1 off and turn **Boom 2** on (top middle switch). Use the (+) or (-) button to set the width (in inches) of the right side of the sprayer coverage area. *(If you do not have left and right section control valves, this would be left at 0.)*
7. Turn dial to **DISTANCE**. If using the Astro II GPS Speed Sensor, this should be 0.189, and should not need to be adjusted. If using the Vansco Radar Speed Sensor, set this at 0.151. Adjust as needed after performing Distance Calibration Verification. *(Measure a 300 foot long course. Drive this course and change Distance measurement on display as needed. See bottom of page 35 for instructions on this procedure.)*
8. Turn dial to **PRESSURE**. Press (+) button to increase **Control Speed** to **(1)**. Adjust as needed in the field for best operation. *(If the system is slow to get to rate, increase this number. If the system overshoots back and forth, and will not lock on to the rate, decrease the Control Speed.)*
9. Turn dial to **RATE**. Use the (+) or (-) button to set the application rate in **gallons per acre (gpa)**.
10. Save these settings by holding the CAL button until the red light goes out.
11. The Commander II controller is ready to go.

### Typical CAL settings for Commander Orchard Sprayer

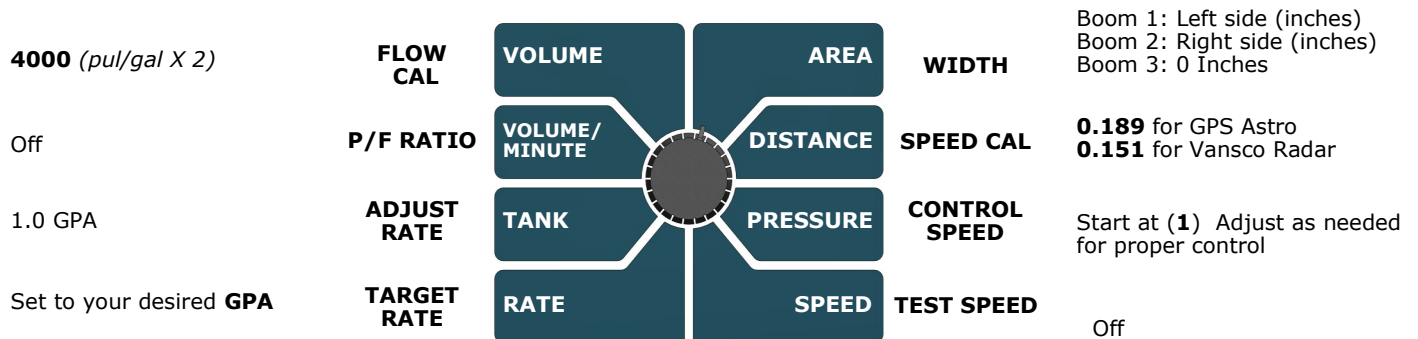



# Initial Operation Instructions



**SurePoint highly recommends you perform these exact steps with water to verify system is correctly installed and ready for field use.**

Test the system in **MANUAL mode**. Test first with the pump off, then with the pump on.

## Step 3

1. Push the AUTO/MAN button until **MAN** is displayed on the Commander II. You are now in Manual mode.
2. Put the system in **RUN**. Turn the console switch to RUN. When HOLD Is not displayed on the screen the system is in RUN.
3. Turn **Boom 1 and Boom 2 switches ON** (top left switch). Left and right section valves should open.
4. Turn dial to **VOLUME/MINUTE** position. Push the (+) button for 5 seconds. The Servo control valve should open. Push the (-) button. The Servo control valve should close. Leave the Servo valve slightly open. Turn the Boom switches OFF.
5. Start the pump. Turn the Boom Switches ON.
6. There should be numbers on the **VOLUME/MINUTE** screen. Hold the (+) button. Flow should increase. Hold the (-) button. Flow should decrease. If no reading in VOLUME/MINUTE, is the pump turning and is there water present at the pump inlet?
7. If water is being pumped, but no reading on the Commander VOLUME/MINUTE, check the flowmeter connections and the Flow Cal value.

**Proceed to STEP 4, ONLY when you can increase and decrease the VOLUME/MINUTE reading using the "+" and "-" keys on the Commander II.**

Now, we will operate the Commander II in **AUTO Test Speed mode**.

## Step 4

1. Enter calibration by pushing and holding the **CAL** button until CAL is displayed on the Commander II and the red light is on.
2. Push the AUTO/MAN button until **AUTO** is displayed, indicating you are in automatic mode.
3. Turn the dial to **Test Speed** in the bottom right corner. Use the + key to adjust to your field operating speed.
4. Turn the dial to **RATE**.
5. Turn Run/Hold switch on Commander II to **RUN**.
6. Turn Boom Switches ON.
7. You should now be dispensing liquid as if you were traveling through the field at the test speed you entered. The RATE should lock on to your Target Rate. You can turn the dial to SPEED and change the speed to see if the system locks on the rate at the new speed. Turn dial to RATE to see if it is on the Rate. Turn dial to PRESSURE to see what the pressure is.
8. Turn Boom Switches OFF. Hold CAL button until red light goes out.

**Proceed to the next step when liquid application is verified in AUTO mode with Test Speed operation.**

Finally, we will verify the Commander II Speed is correct.

Turn the dial to **SPEED**. Drive the tractor. Compare the Speed on the Commander with the tractor speed. The Astro speed sensor is probably more accurate than the tractor speedometer. **If using the Vansco Radar Sensor, verify the Distance/Speed setting using the procedure at the bottom of page 35.**

## Step 5

In general, if the speed on the Commander II is too slow, increase the Speed/Distance Cal number. If the speed on the Commander II is too fast, decrease the Speed/Distance Cal number.

**When your Commander II Ground Speed is correct, you are ready to verify regular field operation.**

# Special Calibration Procedure - Page 1



The following 3 pages are General Reference information and should not be needed for normal operation.

Special Cal Parameters should not need changed in most cases. Consult with your SurePoint dealer or representative before adjusting.

To enter Special Cal:

1. Power off Commander II
2. Enter Special Cal by holding both the AUTO/MAN and the CAL button down while turning on the power switch.
3. You should see "SPEC" on the screen, if not, repeat steps one and two.
4. Save changes by holding CAL until red light goes out.

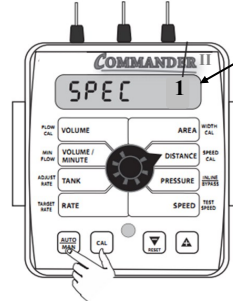

**FILL TANK SIZE:** If using the Tank feature, this setting can be used to enter the volume of the tank. Use the "+" and "-" buttons to choose OFF or any value from 1-65,535. Then when the tank is filled, the tank counter can be reset to full by simply turning the rotary switch to the TANK position and pressing the "+" button.

**TANK ALARM SET POINT:**

Use the "+" and "-" buttons to set the level where the Warning LED starts flashing and the word "FILL" flashes on the display. Range is OFF or 1-65,535. When the tank value drops below the set point, the alarms will notify the user that the tank level is low.

**AUTO SHUTOFF ON/OFF:**

Not used for PWM systems. When Auto Shutoff is enabled (ON) the servo will run toward minimum flow for 4 seconds any time the system is put in HOLD or all booms are turned off, or if in AUTO mode and speed goes to zero. This feature is normally used only in Dry Application systems where the HOLD condition must stop a hydraulic auger or conveyor belt.

### Special CAL 1 Settings

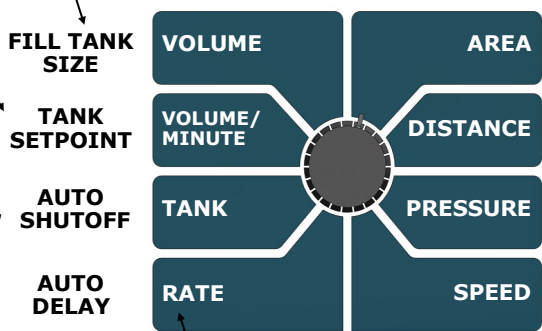

**FILL TANK SIZE**

**TANK SETPOINT**

**AUTO SHUTOFF**

**AUTO DELAY**

**VOLUME**

**VOLUME/MINUTE**

**TANK**

**RATE**

**AREA**

**DISTANCE**

**PRESSURE**

**SPEED**

**SET DEFAULTS**

**FLOW CAL DEC**

**CONTROL MODE**

**VALVE POLARITY**

**SET DEFAULTS / COMMANDER II SPECIAL CAL QUICK SETUP:** See page titled COMMANDER II SPECIAL CAL QUICK SETUP.

**FLOW CAL DEC:** Sets the number of decimals available when entering the Flow CAL number in standard calibration mode. Defaults to 1 (Flow cal sets to whole number).

**CONTROL MODE:** Allows the selection of either Servo mode or PWM mode. The selection is made based upon your specific equipment. On power up, the mode is displayed briefly as "S Flo" for servo mode and "P Flo" for PWM mode.

**AUTO DELAY TIME:** Not used for PWM systems. Typically used when using relatively slow ball valves for boom shut-off, this feature delays adjustment of the servo valve until the boom valves are open. Use "+" and "-" buttons to set from zero (OFF) to 4 seconds.

**VALVE POLARITY:** Not used for PWM systems. For establishing servo polarity. If pushing increase button causes flow to decrease and vice versa, switch this setting between Inline and Bypass.

**Special CAL Page 1 Factory Defaults:**

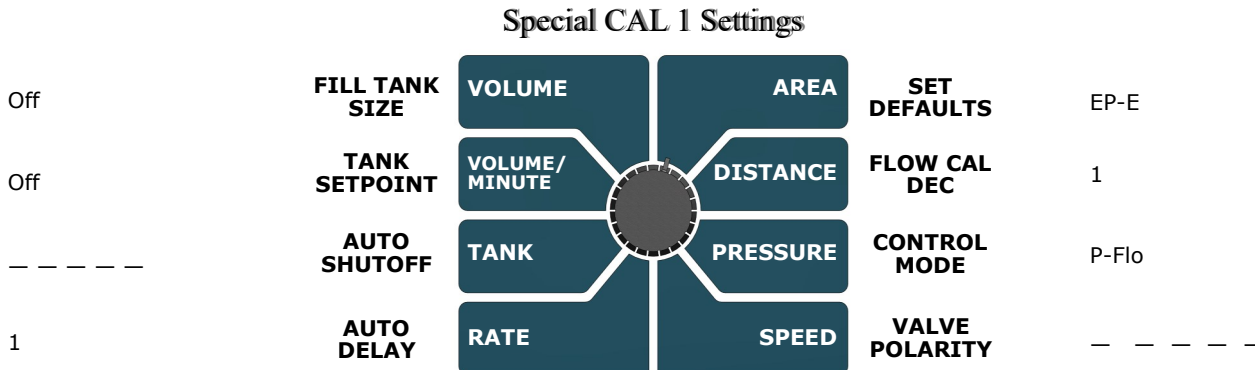

# Special Calibration Procedure - Page 2



**Special Cal Parameters should not need changed in most cases.** Consult with your SurePoint dealer or representative before adjusting.

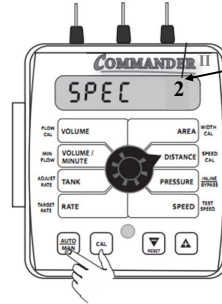

This number tells you which special CAL screen you are on. Pressing the CAL button will change this number.

**MIN PRESSURE:** Sets the value of the minimum pressure alarm. When the pressure drops below this setting, an alarm will occur. **PRESS ALM MIN SPEED** can be used to disable alarm when speed drops below **MIN SPEED**.

**MIN PRESSURE ALARM MINIMUM SPEED:** This setting is used in conjunction with the **MIN PRESSURE** setting. It is disabled when **MIN PRESSURE** is off and sets the **MIN SPEED** at which the **MIN PRESSURE** alarm can occur when a setting is present in the **MIN PRESSURE** location. If **MIN PRESSURE** is set to 5 PSI and **PRESS ALM MIN SPEED** is set to 2 MPH, then the alarm will only occur if you are moving faster than 2MPH, otherwise it will be disabled.

**MAX PRESSURE:** The system alarms if the pressure gets above this setting. This cannot be set higher than the pressure full scale setting. Set at 250 for Orchard sprayer.

## SPECIAL CAL 2 Settings

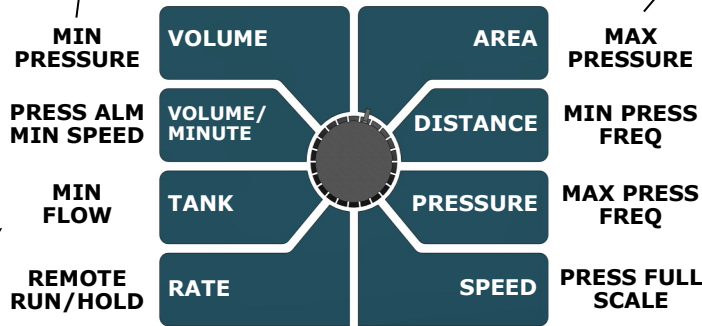

**MIN PRESSURE FREQ:** Set at the factory. Do not change.

**MAX PRESSURE FREQ:** Set at the factory. Do not change.

**MIN FLOW:** The purpose of this calibration value is to prevent the system from applying below the recommended minimum rate for spray nozzles. **For non-spraying applications, nearly always leave this at ZERO.** To use, enter the minimum flow rate in gallons per minute for the entire boom on the sprayer. **DO NOT** enter the actual flow of your spray application. For example: If the minimum flow rate for the nozzle you are using is .22 GPM at their minimum recommended pressure and your boom has 20 nozzles, enter 4.4 as the **MIN FLOW** value (.22 x 20 = 4.4). The system **WILL NOT** apply at a rate lower than this value when spraying in **AUTO**.

**REMOTE RUN/HOLD:** Set to rHold to use a remote hold switch such as the SurePoint mercury work switch. Set to **Speed** for using a remote speed signal such as a speed sensor that is placed on the implement and plugged into the final pump harness.

**PRESSURE FULL SCALE:** Set this to the maximum reading of the pressure transducer. For the SurePoint Orchard Sprayer System set this at 400.

### Special CAL Page 2 Factory Defaults:

	Special CAL 2 Settings				
Off	<b>MIN PRESSURE</b>	<b>VOLUME</b>	<b>AREA</b>	<b>MAX PRESSURE</b>	Electric: 50 Hydraulic: 80
----	<b>PRESSURE ALARM</b>	<b>VOLUME / MINUTE</b>	<b>DISTANCE</b>	<b>MIN PRESS FREQ</b>	approx. 200—do not change
0.0	<b>MIN FLOW</b>	<b>TANK</b>	<b>PRESSURE</b>	<b>MAX PRESS FREQ</b>	approx. 1000—do not change
rHold	<b>REMOTE RUN/HOLD</b>	<b>RATE</b>	<b>SPEED</b>	<b>PRESS FULL SCALE</b>	100

# Special Calibration Procedure - Page 3



**Special Cal Parameters should not need changed in most cases.** Consult with your Sure-Point dealer or representative before adjusting.

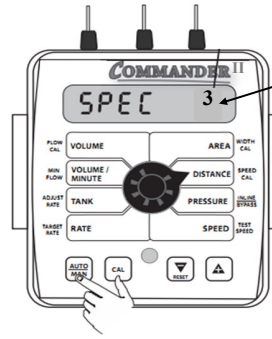

This number tells you which special CAL screen you are on. Pressing the CAL button will change this number.

**START TIME & VALVE START %:** These settings set how far open the valve will open and how long it will stay at that setting on startup. These settings are only available in PWM mode. If the START TIME parameter is Off, then the VALVE START % will be unavailable. These settings will allow the system to get up and operate at a predetermined speed for a predetermined amount of time. Once the START TIME has been reached, the auto control takes over from that point. This is a very good method of smoothing out startup (switching from hold to run).

## Special CAL 3 Settings

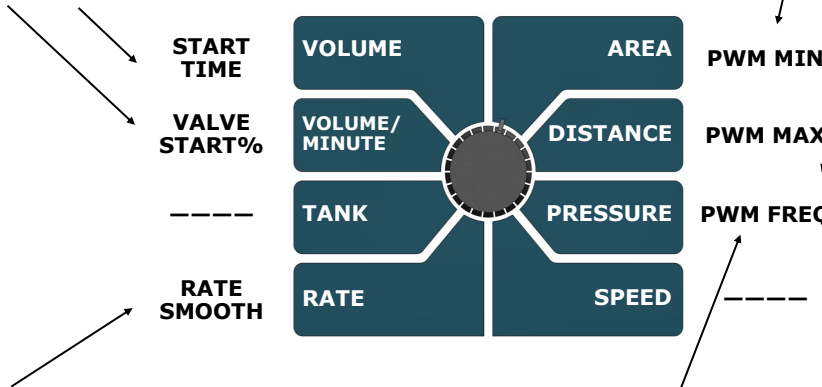

**PWM MIN %:** This setting affects how low the PWM signal can go. If set to 10, then the PWM signal can go down to 10%. If set to 20, then the PWM signal can go down to 20%. Most valves have a bottom end where they no longer change any flow. This is the point where the PWM MIN should be set. If this is set too high, it will keep the system from getting to your lowest rates.

**RATE SMOOTHING:** This value is used to help the system lock on to the target if all system parameters seem to be functioning appropriately.

**PWM FREQ:** Set this to match your PWM valve frequency or set it to the PWM frequency expected by the device you are connecting to.

**PWM MAX %:** This setting affects how high the PWM signal can reach. If set to 100, then the PWM signal can reach 100%. If set to 80, then the PWM signal can reach 80%. If a valve is being used that does not have any control after it gets to a certain point, then that point should be your PWM MAX % setting. If this is set too low, it will keep the system from reaching maximum rate.

## Special CAL Page 3 Factory Defaults:

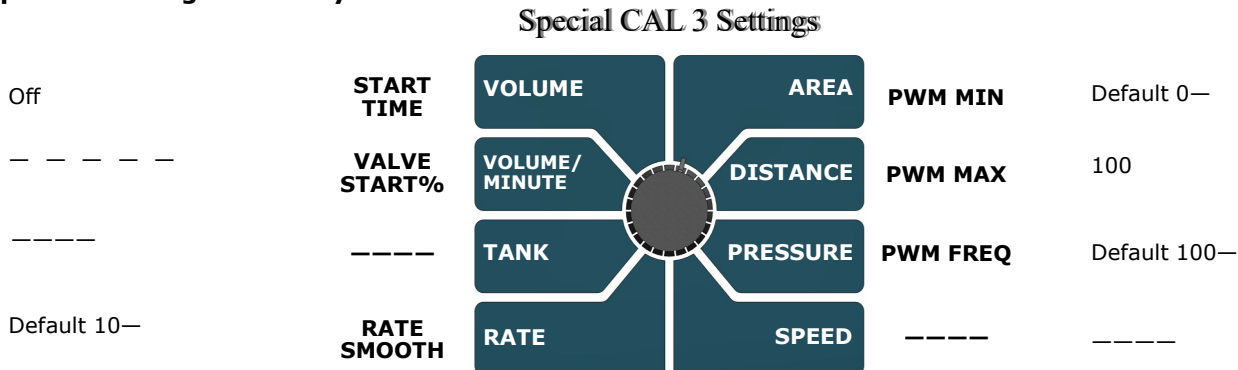

# Commander II Orchard Sprayer console setup

1. Power off Commander II.
2. Enter **Special Cal** by holding both the AUTO/MAN and the CAL button down while turning on the power switch.
3. You should see “**SPEC**” on the screen, if not, repeat steps one and two.
4. Ensure “1” displays to indicate Page 1 in Special Cal. Press CAL to change if necessary.
5. Turn dial to point at **AREA**, Select “**HS-E**” for Orchard Sprayer with Servo control (and English units). *(Press the UP or DOWN arrow to change selection.)*
6. Turn dial to **SPEED**. Select **InLin(e)**.
7. Press **CAL** to go to Page 2.
8. Turn dial to **SPEED**. Hold (+) button to set **Full Scale Pressure** to **400**.
9. Turn dial to **AREA**. Set **MAX PRESSURE** to **250**.
10. *(Do this step if Radar or GPS Speed Sensor is located on the sprayer and is plugged into the final pump harness. Skip this step if speed sensor is plugged into connector behind the Commander II).* Turn dial to **RATE**. Set to **SPEED**.
11. Save changes by holding CAL button until red light goes out (about 3 seconds).
12. Enter **CAL** mode by holding CAL button until the red light comes on.
13. Turn dial to **VOLUME**. This is the flowmeter calibration number. It should be the number of pulses per gallon for the flowmeter multiplied by 2. (On the SurePoint 1.3—26 gpm electromagnetic flowmeter, this will be set at **4000**.)
14. Turn dial to **AREA**. Turn on **Boom 1** (top left switch). Use the (+) or (-) button to set the width (in inches) of the left side of the sprayer coverage area. *(If you do not have left and right section control valves, this would be the spray width of the entire sprayer.)*
15. Turn Boom 1 off and turn **Boom 2** on (top middle switch). Use the (+) or (-) button to set the width (in inches) of the right side of the sprayer coverage area. *(If you do not have left and right section control valves, this would be left at 0.)*
16. Turn dial to **DISTANCE**. If using the Astro II GPS Speed Sensor, this should be 0.189, and should not need to be adjusted. If using the Vansco Radar Speed Sensor, set this at 0.151. Adjust as needed after performing Distance Calibration Verification. *(For this verification process, you will drive a known distance (say 300 feet) and compare that to the distance shown on the Commander II display. Instructions are at the bottom of page 35.)*
17. Turn dial to **PRESSURE**. Press (+) button to increase **Control Speed** to **(1)**. Adjust as needed in the field. *(If the controller adjusts too slowly to speed or rate changes, increase the Control Speed. If the controller overshoots and goes back and forth, above and below the rate, decrease the Control Speed.)*
18. Turn dial to **RATE**. Use the (+) or (-) button to set the application rate in **gallons per acre (gpa)**.
19. Save these settings by holding the CAL button until the red light goes out.
20. The Commander II controller is ready to go.
21. Follow the “Initial Operation Instructions” for testing the system in MANUAL and AUTO mode.



# Section Valve(s) will not move

G

Troubleshooting

1. Check the harness connection to that valve. It is a 3-Pin Weather Pack connector. See Section D for wiring diagrams

Pin	Function
A	+ 12 V Constant
B	Ground
C	+ 12 V Signal

2. Check voltage pin A to Pin B. Must be 12 volts, if not, go back to 10-pin on Commander II and check voltage (pins J & K, white and black wire).

3. If voltage is present on pins A&B of 3-pin connection to valve, then check pin C to Pin B. This should be 12 volts when the valve is commanded on or open, this should be zero volts when valve is off or closed.

4. If signal voltage is not present to open valve, use diagrams to check at the 10-pin connector on back of Commander II.
5. If constant voltage (Pins A&B) and switched voltage (Pins C&B) are present, inspect, repair or replace the valve.

## Console is Erratic in Operation

- If you have a **two-way radio**, it may be mounted too close to the console. Keep all cables away from the radio, its antenna and power cable.
- **Ignition wires** may be causing the console to malfunction. Keep cables away from ignition wires or install ignition suppressor.
- Reroute all cables away from **electric solenoids, air conditioning clutches** and similar equipment.

## Console Appears Dead

- Using your voltmeter, check for 12 volts at Commander power connector. Check for damaged power cable or reversed terminals. Check fuse in power cable and any other fuses or circuit breakers in path. Inspect connections to Commander II power switch.

## Commander II Error Messages

Message	Description
Lo P	Low Power to Commander II, check all power and ground connections
no SPEEd	Will flash in display if dial is in RATE position and there is no speed signal regardless of all other conditions. Check speed sensor and connections. (When vehicle is not moving, this is a normal condition)
no FLo	Will flash in display if rotary switch is in Rate position and should have flow (In Run, some sections on, speed greater than zero) but no flow is detected. Check flowmeter and flow harness connections.
no FLo StoP	Pumps will stop and this message will be displayed if no FLo condition continues for 60 seconds. Console Power must be cycled to reset this condition. Check flowmeter and connections. Use Manual mode for priming and plumbing troubleshooting to avoid this error.
no boom	Will flash in display if dial is in Width position in Cal mode and no sections are turned on.
FILL	Will flash in display if tank level is equal to or less than tank set point. Adjust these settings in Special Calibration.
SPEC	Appears when entering Special Calibration mode
CLEAR	Alerts user that the currently selected counter will be reset to zero if RESET button is held for 2 seconds.
OFL	Displayed when a DISTANCE, AREA or VOLUME counter has overflowed their maximum value. Hold RESET button for 2 seconds to reset the counter.

# Application Rate & Flow Troubleshooting

# G

Trouble-  
shooting

## Application Rate Fluctuates

First, you need to determine if the fluctuation is caused by the controller sending fluctuating signals to the valve.

1. **Inspect & clean pump inlet strainer.** Strange flow rate fluctuations are very often due to an obstruction to the pump inlet. Inspect plumbing from tank to pump.

OR

1. Go to **Manual Mode** and turn system on.
2. Turn dial to VOLUME/MINUTE position. Use the +/- buttons to get to a flow similar to field operation.
3. If there is a large fluctuation in flow on the Commander II, visually observe the liquid flow. Is the discharge a steady stream; are the flow indicator balls floating steady?
4. If visually the flow is steady, but the display reports a fluctuation in GPM, inspect the flowmeter. See section B for flowmeter information.
5. If visually the flow is unsteady, the flowmeter is working correctly reporting a flow problem. Is the pump turning steady or surging?
6. Look for any type of obstruction in the pump inlet. Clean the strainer. If continually plugging the strainer, investigate fertilizer quality and necessary strainer size.
7. Look for air bubbles in the flow. These can be seen in the flow indicators. Air bubbles indicate an air leak on the pump inlet allowing the pump inlet to suck some air.

## Application Rate fluctuates in field, but flow in Manual mode is stable.

1. Turn dial to SPEED. Look for any wild fluctuations in speed indicating a sensor problem.
2. Change the Valve Control Speed in Cal Mode by reducing the value (range is -4 to +3).

## Application Rate is slow to get to the Target Rate

1. You may need to increase the Control Speed in Cal mode (range is -4 to +3) if system is slow in returning to Target Rate when speed changes.

## No Flow shown on Commander II but liquid is being pumped

1. Unplug flowmeter. With voltmeter, check for 12 volts between pins 1 and 2 of flowmeter connector (on main harness PN 200-03-4036Y1). If 12 volts not present, inspect wiring harness and troubleshoot all connections per schematic (see Section D).
2. If 12 volts is present, then conduct a tap test. Enter CAL mode and change the flow cal to 10. Have a second person watch VOLUME/MINUTE while other person taps (use a short piece of wire or a paper clip) between pins 1 and 3 of flowmeter connector (on 200-03-4036Y1 harness). A flow value should show up indicating the wiring is not damaged.
  - If working alone, you can set dial to VOLUME and reset a counter to zero. Then tap approximately 20 times and see if the Commander II volume counter has changed.
3. If Commander II responded to the tap test, your wiring to that point is good. If still not fixed, inspect adapter harness and test continuity per schematic (see Section D)
4. Replace flowmeter.
5. Reset flow cal to 4000 when finished testing.



# Flowmeter is inaccurate

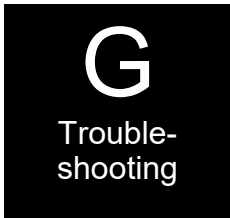

This procedure is used to verify and fine-tune the flowmeter calibration. With Electromagnetic flowmeters, it should not be necessary to change the Flow Cal. However, **SurePoint recommends always running a catch test to verify accuracy and that Commander II is setup correctly.**

## PROCEDURE

1. Put enough water in the tank to perform this test. **(The larger the volume of water used, the more accurate the calibration will be).**
2. Start pump and turn on sections. Run enough water to purge all air from lines. Turn off pump.
3. Turn console rotary selector to the VOLUME position. Select the counter (1-3) that you want to use. Press and hold the RESET button until the display reads 0 **(about 2 seconds).**
4. Turn on all sections, and run a known amount of water.
5. Turn off all sections. Compare the console's VOLUME reading with the known amount of water run. If the two amounts are within one or two percent, no fine tuning is required. If the two amounts are more than two or three percent different, continue with the next step.
6. With the console still in the VOLUME position, enter calibration **(Boom switches OFF, hold the CAL button until red warning light comes on; about one second).** The display will show the flowmeter

7. Momentarily press the CAL button. The CAL icon will begin to flash and the total volume will be displayed.
8. When the TOTAL FLOW value is displayed, use the "+" or button to adjust the value to match the amount of water run.
9. Momentarily press the CAL button. The word CAL and the flowmeter calibration number will be displayed. You will notice that the flowmeter calibration value has changed. Write down the new flowmeter calibration value. This is your "fine tuned" calibration value, keep it for future reference.
10. Exit calibration by holding the "CAL" button until the red warning light goes out (about one second).

**NOTE: The most accurate method to measure the volume of water run is to place a container under every nozzle** and add together the amount from each nozzle. This assures that 100 percent of the water is collected and that all rows are equal. At a minimum collect water from 4 - 6 rows. NEVER base a calibration on a single row catch. It is important to perform this procedure at a flow rate similar to that which will be used in the field.

# Speed is inaccurate (Speed / Distance Verification)

This procedure is used to drive a known distance and find the Speed Cal for your setup. The Astro GPS Speed Sensor Cal should be 0.189 and should not need to be changed. Set the Vansco Radar at 0.151 and verify by the following process:

1. Place a flag at the beginning and end of a straight 300 foot measured course.
2. With the console turned ON, place the Run/Hold switch in the HOLD position. The HOLD icon will be displayed. Turn the rotary dial to the "DISTANCE" position. Be sure the display shows 0. If not, reset the distance counter by pressing and holding "RESET" until the display returns to 0 (approximately one second).
3. Place the Run/Hold switch in RUN when the vehicle passes the starting flag to activate the distance counting function. The console display numbers will increase, adding to the distance total as you drive. Drive the pre-measured course and place the Run/Hold switch in HOLD, when the vehicle passes the ending flag, to stop the distance counting function. The console display should read "HOLD". **Stop the vehicle in a level and safe area** and continue with this procedure.
4. With the rotary dial still at DISTANCE (SPEED CAL), press and hold the "CAL" key for one second. Once the console is in "CAL," CAL and the speed calibration value will be displayed. Momentarily press CAL and the word CAL will begin to flash and the distance travelled will be displayed.
5. When the display shows distance ("CAL" is flashing), verify whether the number displayed is the exact distance you drove (300 ft. +/- 1 - 2 %). If not, press the "+" or "-" key to adjust the figure to match the distance you actually drove. If the display reads too high, use the "-" key to lower the displayed value. If the display reads too low, use the "+" key to raise the displayed value.
6. When the number shown on the display matches (as closely as possible) the actual distance driven, you have arrived at the correct Speed Cal. You may check the calibration number by momentarily pressing CAL. The word CAL and the SPEED CAL number will appear. Exit "CAL" by pressing "CAL" for one second.
7. Repeat test until a consistent 300 feet is measured.

## I want to match Commander II speed to Tractor Speed

Use the equation below to calculate a new Speed Cal to enter in Cal mode. The Astro GPS Speed Sensor Cal should be 0.189 and should not need to be changed.

*Hint: If you change the Commander II Speed Cal to 1.0 first, it makes the math very easy.*

$$\text{New Speed Cal} = \text{Old Speed Cal} \times \text{Tractor Speed} / \text{Commander II Speed}$$

# Recommended Care and Maintenance

# H

Maintenance  
& Parts

## Winterization

SurePoint recommends flushing your fertilizer pump and complete system with adequate amounts of water first. Next, use RV antifreeze to winterize your system by pumping an adequate amount through all components. At the beginning of the next season, begin with water to verify the system is in working order with no leaks.

## Pre-season Service

1. Visually check entire system (hoses, fittings, harnesses, etc.) for any signs of wear or trouble. If harnesses have had fertilizer on them, check to see if any pins are corroded.
2. On the display, recheck all setup screens (see Section F) to verify correct setup.
3. Fill system with water and run in Manual mode to verify components and system are in working order. (May need to open air bleed valve pump to prime pump the first time.)
4. **Tighten all clamps.** Loose clamps may be evident by leaks on the output side of the system. Loose clamps from the tank to the pump are not always apparent, but can be sources of air getting into the system which can create issues.
5. Remove and clean the strainer. Be sure strainer is tightened securely so it will not suck air.
6. Be sure all rows are flowing and that all tips and tubes are open.
7. Run the system in AUTO Test Speed Mode to verify that system will lock on to a Target Rate.

SurePoint Ag Systems  
9904 Hwy 25  
Atwood, KS 67730  
[www.SurePointag.com](http://www.SurePointag.com)  
©2010-2018 SurePoint Ag Systems



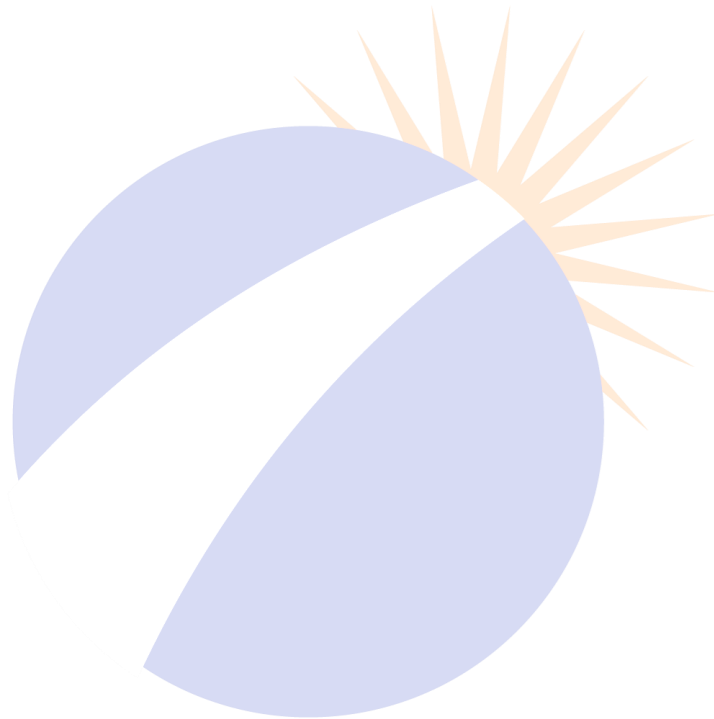

*SurePoint*



*Ag Systems*