

396-001440

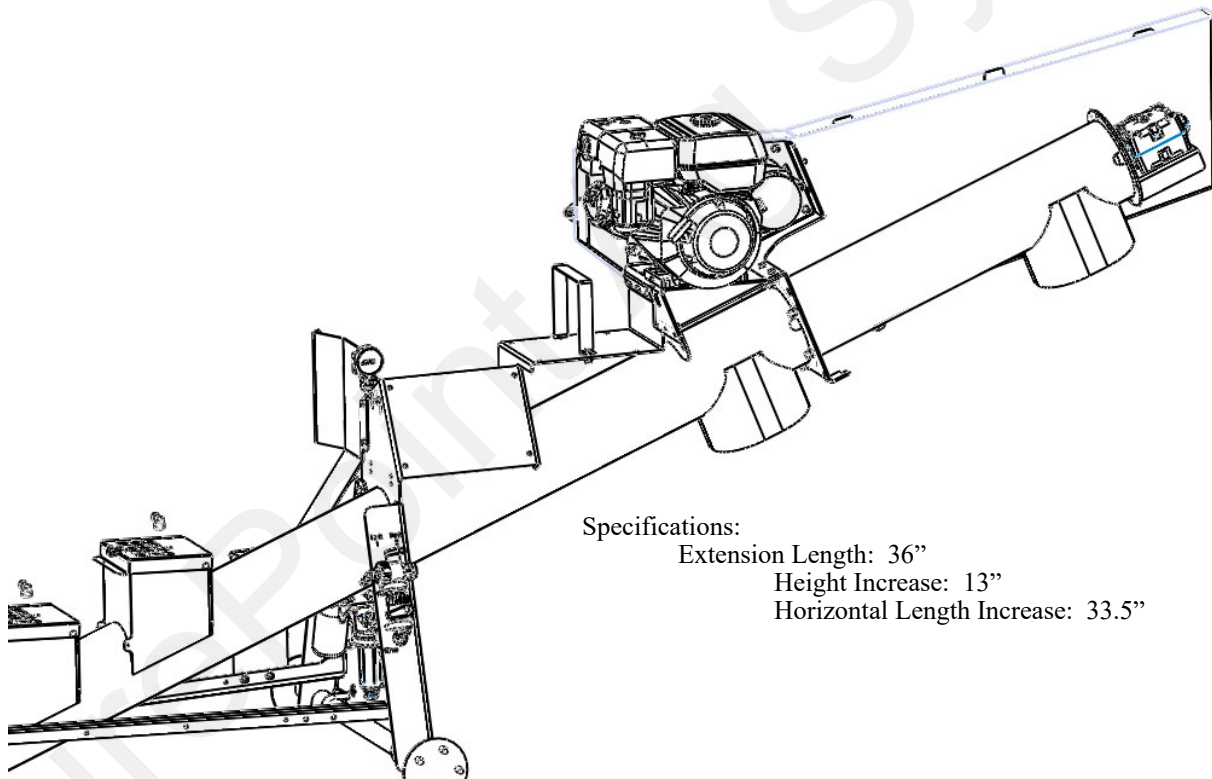

Super Treater 3 Foot Auger Extension Kit Installation Instructions



Specifications:

Extension Length: 36"

Height Increase: 13"

Horizontal Length Increase: 33.5"

These instructions show how to install a 3 foot Auger extension kit onto the SurePoint Super Treater.



Steps to remove belt drive parts from standard length Super Treater

1. Open belt shield by removing lynch pins and lifting outer half off.
2. Pivot alternator to loosen belt, then remove belt.
3. Next remove both the engine or electric motor pulley and the gearbox driven pulley. To remove the pulleys, unscrew the three 1/4" bolts out of each pulley hub. Then screw the bolts into the threaded holes in the hub. Screw the bolts in evenly to press the pulley off the hub.
4. Remove the inside fixed half of the belt shield.
5. You can discard both halves of the original belt shield and the original belt. These will not be used.
6. Keep all the pulleys as these will be reused.

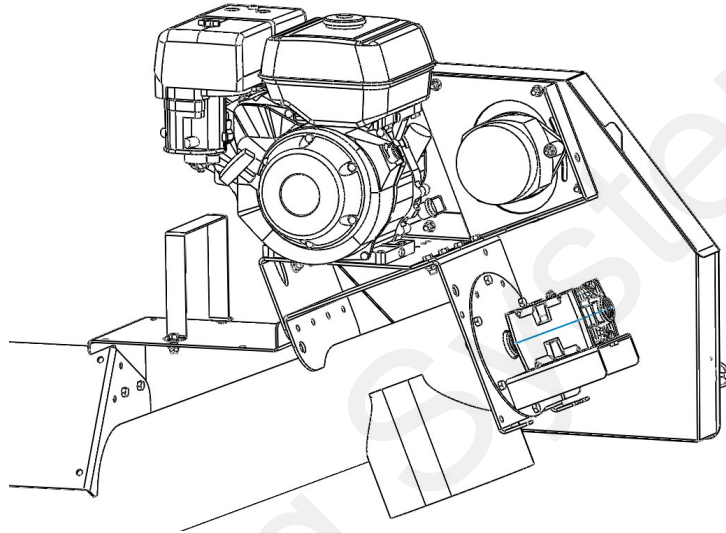

3 bolts are threaded through hub into pulley to clamp pulley onto shaft. Remove bolts and thread into the three threaded holes in the hub. Screw in evenly to press pulley off of the hub.

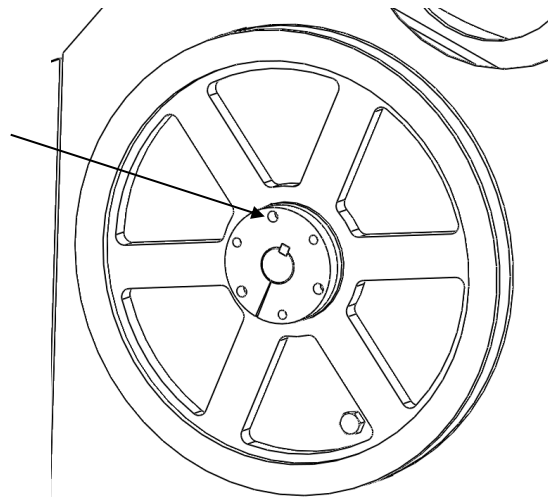

Steps to remove gearbox and auger from standard length Super Treater

The auger and gearbox may be difficult to separate if they have ran for extensive time conveying fertilizer.

1. Remove the 6 bolts holding the gearbox support plate onto the Super Treater.
2. Slide the auger, support plate and gearbox out as 1 piece.
3. Loosed the set screw holding the auger keyway in place.
4. Holding the gearbox securely, pull the super treater auger off the gearbox shaft. If the auger will not come off, you will have to replace the gearbox to install this kit. If that is the case, cut the auger shaft close to the gearbox support plate. Remove the support plate to reuse with this kit.

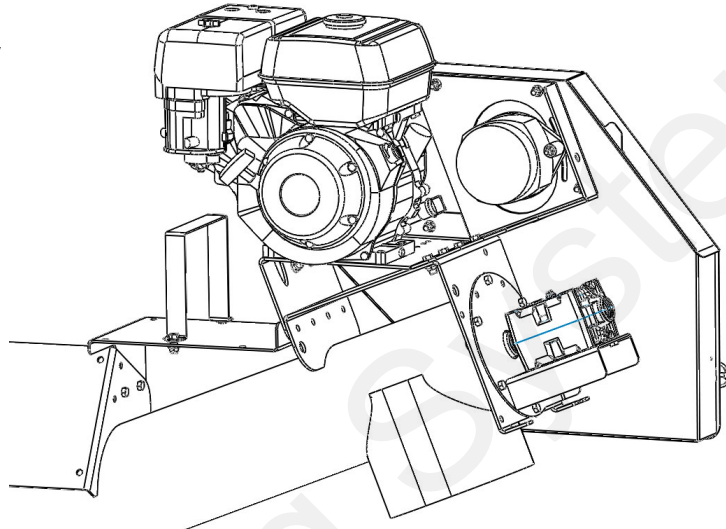

Steps to install Super Treater 3 foot extension.

1. Install the cover plate over the original auger discharge spout. Place the cover plate inside the super treater. We recommend you use a 90 degree compact drill as shown at right. Drill 1 pilot hole in the auger tube using the cover plate as a template. Expand this hole from the outside to 3/8" and install one bolt. Repeat this process until all 6 bolts are installed.
2. Bolt the auger tube extension AND the new idler pulley bracket into place. The idler pulley bracket is attached by the 3 bolts circled that also attach the auger tube extension. For easiest assembly, attach the tube extension first with bolts on opposite side. With tube extension held in place, then insert bolts that hold tube extension and idler pulley bracket.
3. Next, slide the long auger into the super treater. Make sure the woodruff key (half moon) is in place as you slide the auger shaft into the lower angle gearbox.
4. Assemble the gearbox support plate onto the upper end of the auger tube extension with six 3/8" bolts.
5. Slide the gearbox into the auger with the keyway in place. Attach the gearbox to the support plate with four 3/8" bolts threaded into the casting. The longer shaft on the gearbox faces the side to be driven by the engine or motor.
6. Tighten the set screw in the auger hub to hold the drive key through the notch in the top of the auger tube extension.

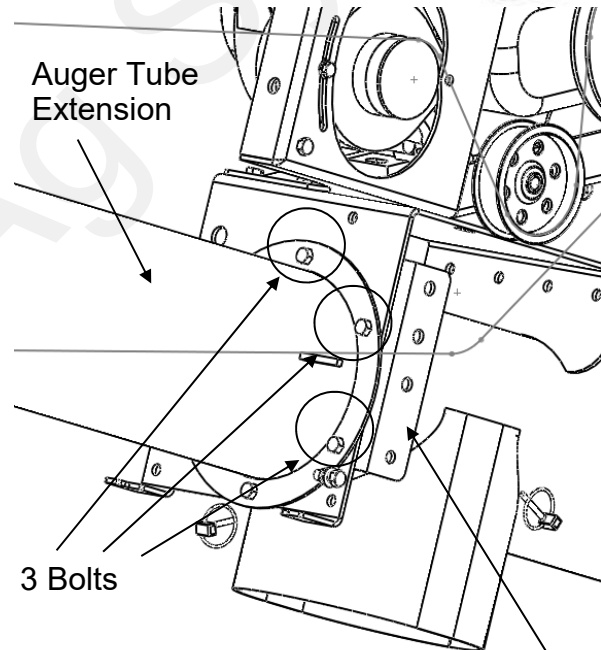

Idler Pulley Bracket

Notch to tighten set screw

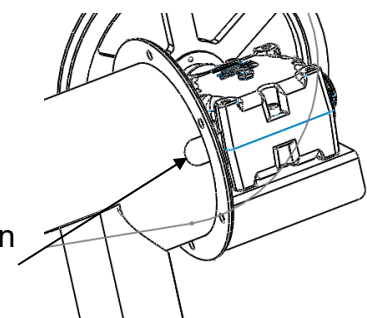

Steps to install Super Treater 3 foot extension belt drive and shields.

1. Install the fixed inner half of the belt shield. You will need to break out the correct hole for your engine or motor shaft. Compare to your original shield to find which hole knockout to remove. The belt shield attaches with seven 3/8" bolts indicated by the arrows in the picture below.

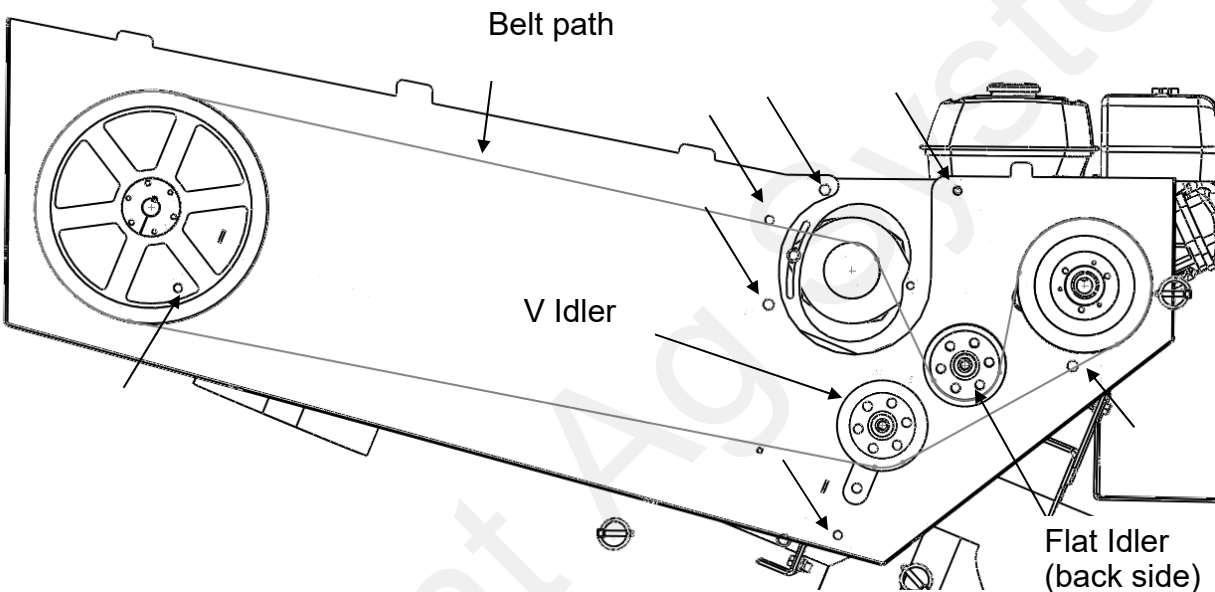

2. Reinstall the pulleys on the gearbox and the engine or motor. Align these pulleys with the alternator pulley.
3. Install the flat idler pulley where shown. You will have to drill out the hole in the engine mounting bracket to fit the 1/2" bolt for the pulley (original hole was 3/8"). Use 1/2" washers to shim the pulley so it aligns with belt drive.
4. Install the V idler pulley where shown. It may mount in one of three holes in the new idler pulley bracket to compensate for belt length and stretch. Mount with 1/2" bolt and shim with 1/2" washers to align belt.
5. Install the belt as shown. Move the V idler pulley to compensate for belt length, then tighten belt with alternator pivot mounting.
6. Install outer half of belt shield and secure with five lynch pins. Attach lynch pins to shield using cotter keys and chains attached to pins.

DO NOT OPERATE SUPER TREATER WITHOUT ALL SHIELDS IN PLACE!