

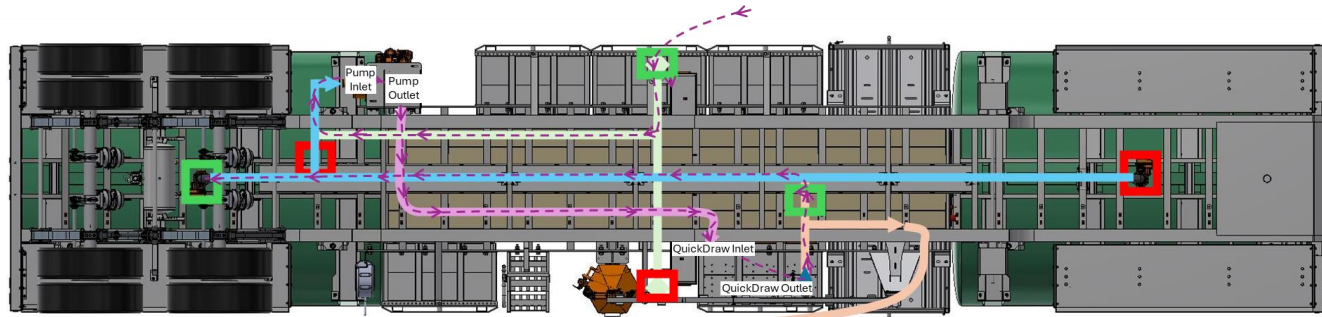

396-6744Y1

Kit: 607-03-200200 - Upgrade 3" Plumbing Kit - From Customer Pump to QD Pump Carrier Refill (add 2 Electric Valves)



Driver Side Plumbing

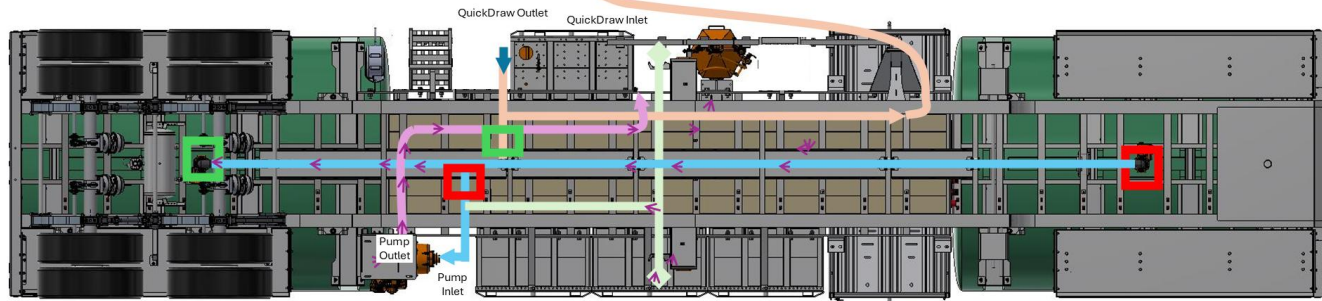

Passenger Side Plumbing

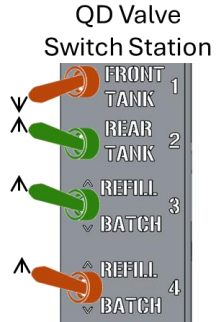



Parts List

Kit: 607-03-200200 - Upgrade 3" Plumbing Kit - From Customer Pump to QD Pump Carrier Refill (add 2 Electric Valves)

Part Number	Description	QTY	Uof M
353-24HD	24" Zip Tie - Heavy Duty 175lb (50/bag)	1	each
105-300G-H	3" EPDM Manifold Gasket	7	each
280-300-SH	3" Fertilizer Solution Suction Hose	20	ft
105-FC300	3" Manifold Clamp	4	each
105-300CPG45	3" Manifold Coupling - 45 Degree	1	each
105-300CPG7	3" Manifold Coupling - 7"	2	each
105-300CR	3" Manifold Cross	1	each
105-300TEE	3" Manifold Tee	4	each
105-300BRB	3" Manifold x 3" HB	2	each
105-300BRB45	3" Manifold x 3" HB - 45 Degree	2	each
353-30WL	30" SS Zip Tie Wraplock Band (10/bundle)	10	each
206-03-10449	3-pin - 10' WP Extension Cable - Servo/ Boom Only (3m)	1	each
206-03-10876	3-pin - 15' WP Extension Cable - Servo/ Boom Only (4.6m)	1	each
206-03-10450	3-pin - 5' WP Extension Cable - Servo/ Boom Only (1.5m)	1	each
208-05-6855Y1	Electric Carrier Refill Valve Control Harness	1	each
103-2417Y1	QuickDraw Valve, 300 Flange, 3" Thru Ball, WP Shroud	2	each
350-TC343	T-Bolt Hose Clamp - 3" Diameter (fits 3" Solution Hose)	4	each

Driver Side Plumbing Upgrade Instructions

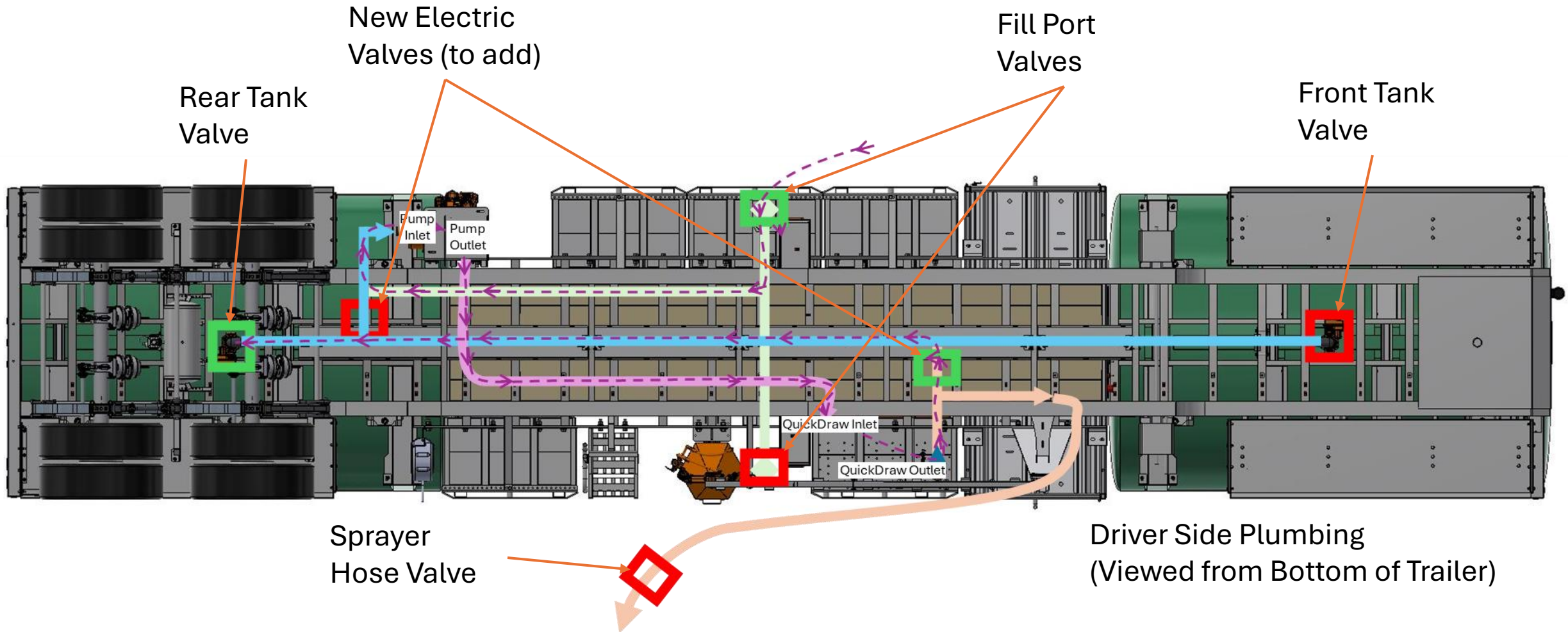

Arsenal Trailer 3" Plumbing Schematic

without Pumped carrier refill

Carrier Refill Upgrade

Step 1. Removal

Different Length Trailer's have varying hose lengths. Passenger and driver side trailers vary in hose length and a few fittings as noted

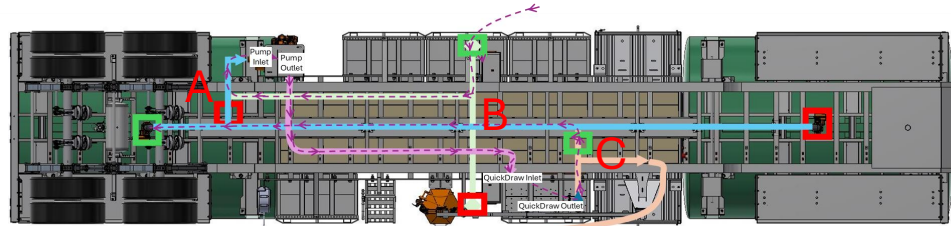

Driver Side Plumbing

Rear Tank

Front Tank

103-2417Y1
Tank Valves Could be Manual Valve

Tank Valves Could be Manual Valve

105-300CPG7
105-300CPG7
105-300CPG
Filter F
A. Disconnect and Remove Both Long couplings

105-300BRB
105-300BRB
105-300CROSS
105-300BRB
B. Disconnect and Remove Cross

QD
Fill Port
C. Disconnect this connection. May have to replace 90 Elbow barb with Straight Barb

Hose Boom

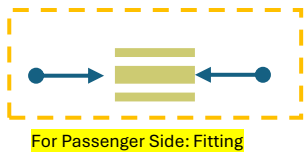

Arsenal Trailer 3" Plumbing Schematic with QD Pumped carrier refill

Different Length Trailer's have varying hose lengths. Passenger and driver side trailers vary in hose length and a few fittings as noted

Carrier Refill Upgrade Step 4. Route Harnesses

Using 3-Pin extension cables as required route 3 pin cables from QD Cabinet to new Valve Actuators. Secure as needed under trailer deck.

Tank Valves Could be Manual Valve

Previous Cross Location

Hose Boom

Front Tank

Tank Valves Could be Manual Valve



For Passenger Side: Fitting

Filter F

See Note for Passenger side

396-6744Y1 - Upgrade 3" Plumbing Kit - From Customer Pump to QD Pump Carrier Refill (add 2 Electric Valves)

© 2023 SurePoint Ag Systems, Inc.

Fill Port

Revised:3/11/26

Page 7

Public

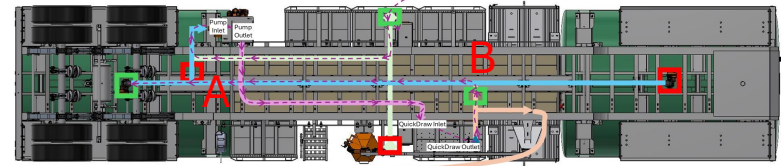
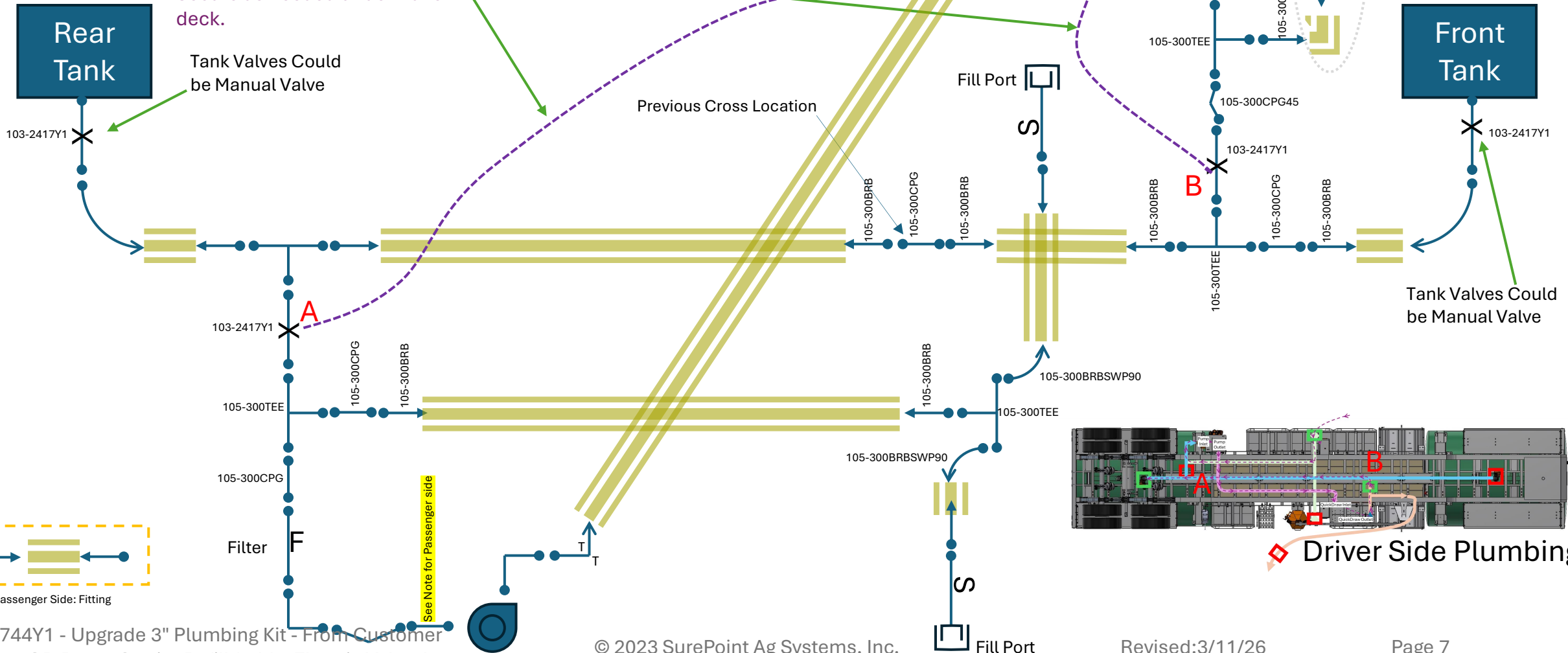

Driver Side Plumbing

Passenger Side Plumbing Upgrade Instructions

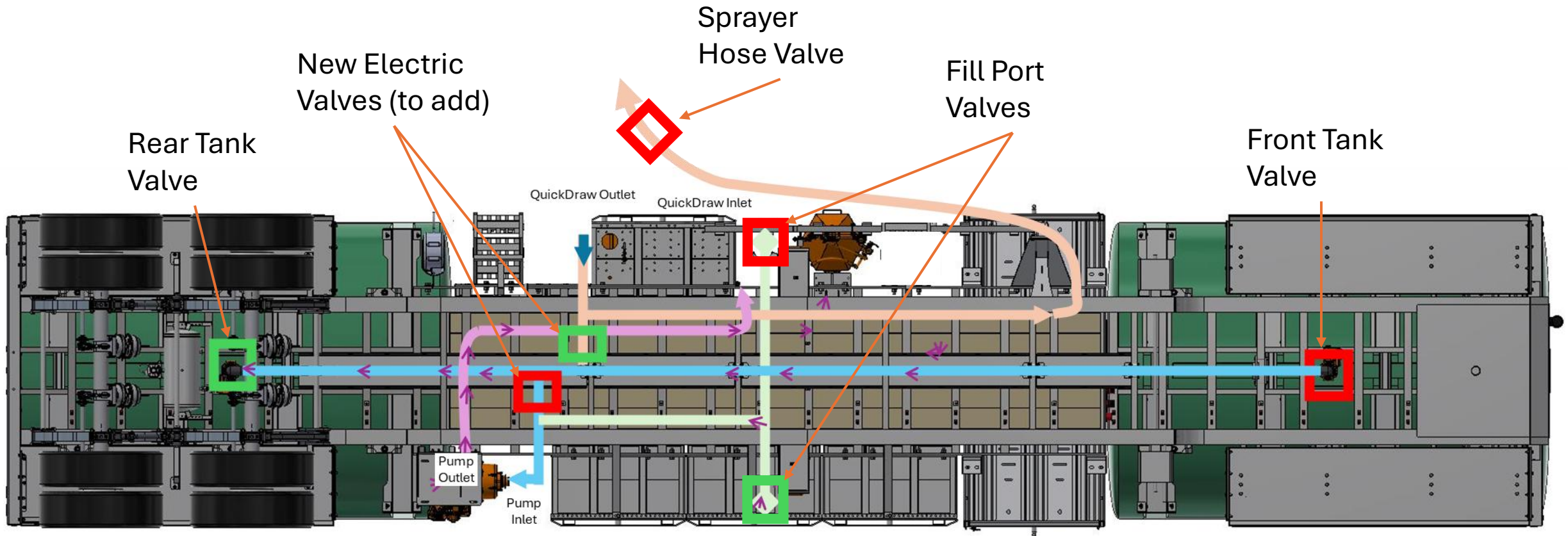

Passenger Side Plumbing
(Viewed from Bottom of Trailer)

Arsenal Trailer 3" Plumbing Schematic without Pumped carrier refill

Carrier Refill Upgrade Step 1. Removal

Different Length Trailer's have varying hose lengths. Passenger and driver side trailers vary in hose length and a few fittings as noted

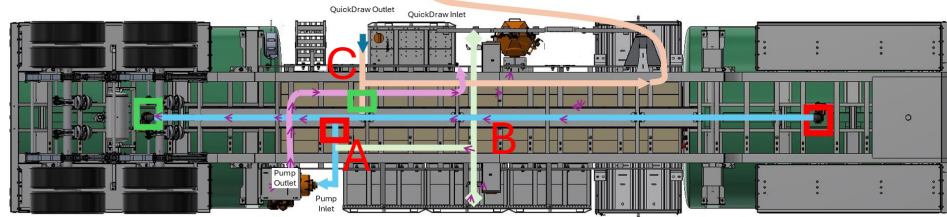

Passenger Side Plumbing

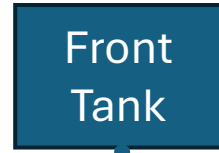

103-2417Y1 Tank Valves Could be Manual Valve

Tank Valves Could be Manual Valve

105-300CPG7
105-300CPG7
105-300CPG
A. Disconnect and Remove Both Long couplings

105-300BRB
105-300BRB
105-300CROSS
B. Disconnect and Remove Cross

QD
Fill Port
C. Disconnect this connection. May have to replace 90 Elbow barb with Straight Barb

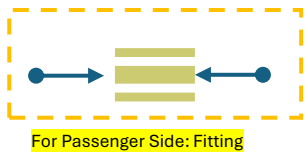

Filter F

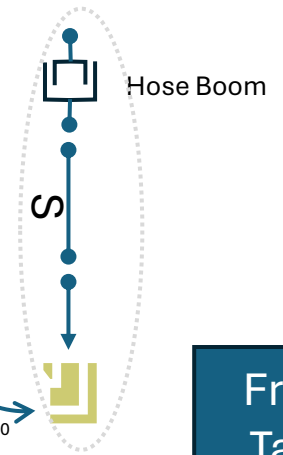
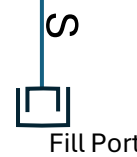
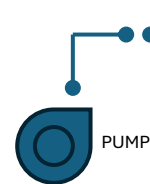

Arsenal Trailer 3" Plumbing Schematic

Different Length Trailer's have varying hose lengths. Passenger and driver side trailers vary in hose length and a few fittings as noted

Carrier Refill Upgrade Step 2. Prepare trunk hose

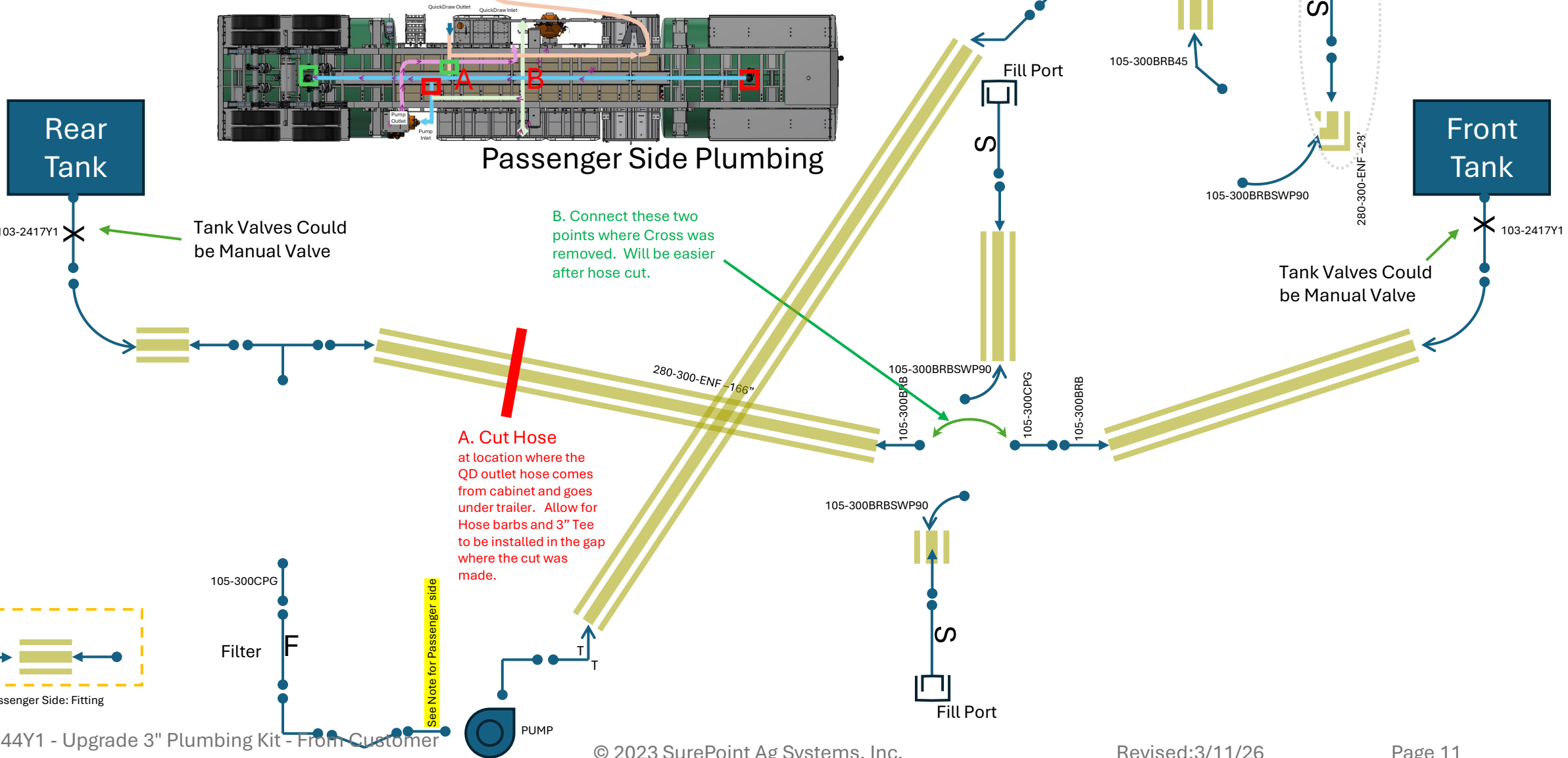

Arsenal Trailer 3" Plumbing Schematic

Carrier Refill Upgrade Step 3. Install Components

Actions:

- Install Tee between Left and Right fill port hoses with Tee pointing Aft
- Install Hose Barbs in Hose cut point, install Tee between those hose barbs, point tee towards QD outlet hose. (additional coupler is optional)
- Install Tee and Electric valve on branch to pump Filter. Actuator should be pointed away from ground as much as possible. Tee shout point forward. (coupler is optional)
- Install Tee and Valve on QD outlet and Boom Hose. Actuator should be pointed away from the ground as much as possible. Use of 45 or 90 couplers as needed to fit-up.
- Cut new hose piece to go from Filter branch Tee to L/R fill port tee. Install Hose barbs and install hose to tees.

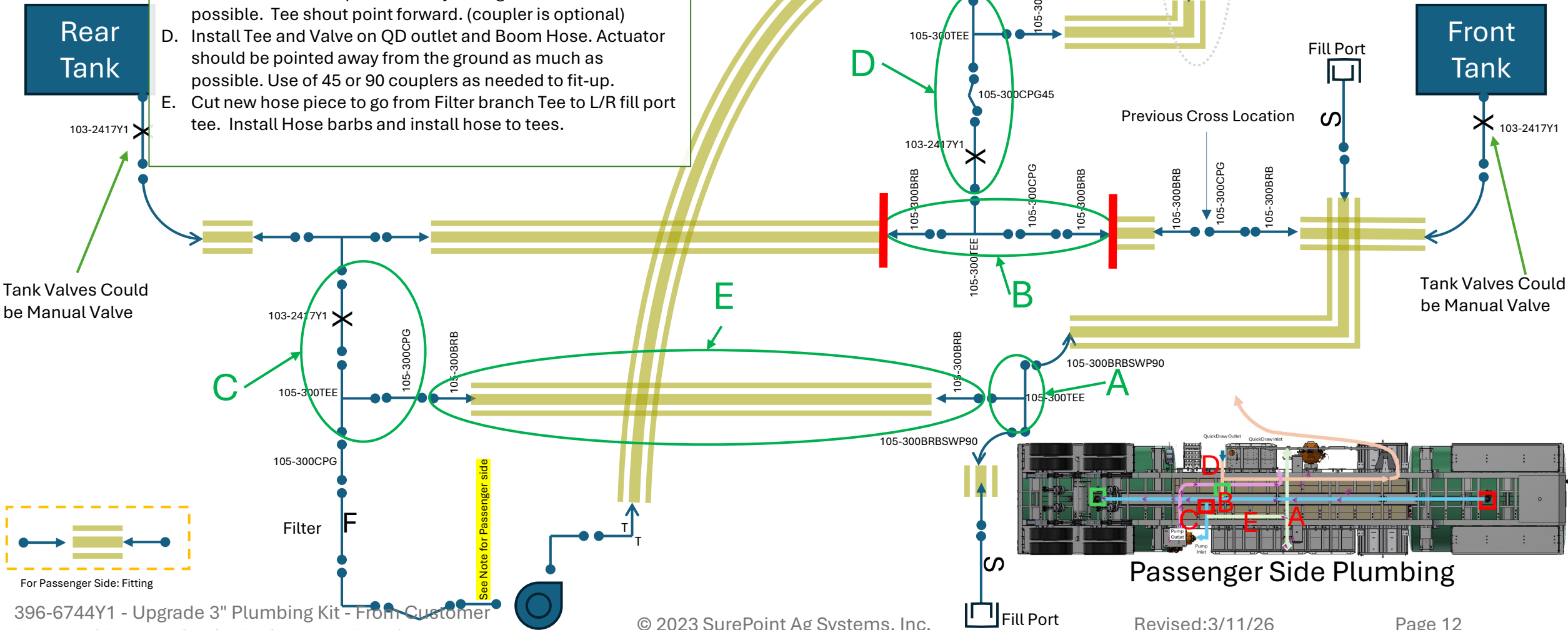

Tank Valves Could be Manual Valve

Tank Valves Could be Manual Valve

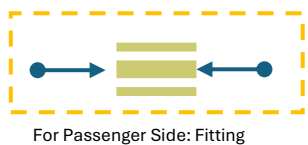

See Note for Passenger side

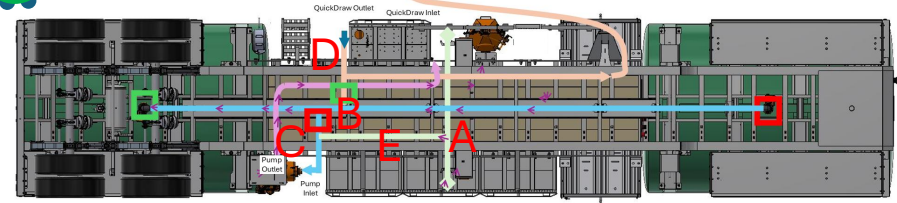

396-6744Y1 - Upgrade 3" Plumbing Kit - From Customer Pump to QD Pump Carrier Refill (add 2 Electric Valves)

Arsenal Trailer 3" Plumbing Schematic with QD Pumped carrier refill

Different Length Trailer's have varying hose lengths. Passenger and driver side trailers vary in hose length and a few fittings as noted

Carrier Refill Upgrade Step 4. Route Harnesses

Using 3-Pin extension cables as required route 3 pin cables from QD Cabinet to new Valve Actuators. Secure as needed under trailer deck.

Tank Valves Could be Manual Valve

Rear Tank

Front Tank



For Passenger Side: Fitting

Filter F

See Note for Passenger side

396-6744Y1 - Upgrade 3" Plumbing Kit - From Customer Pump to QD Pump Carrier Refill (add 2 Electric Valves)

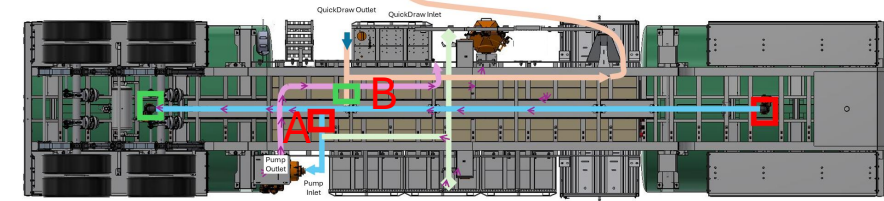
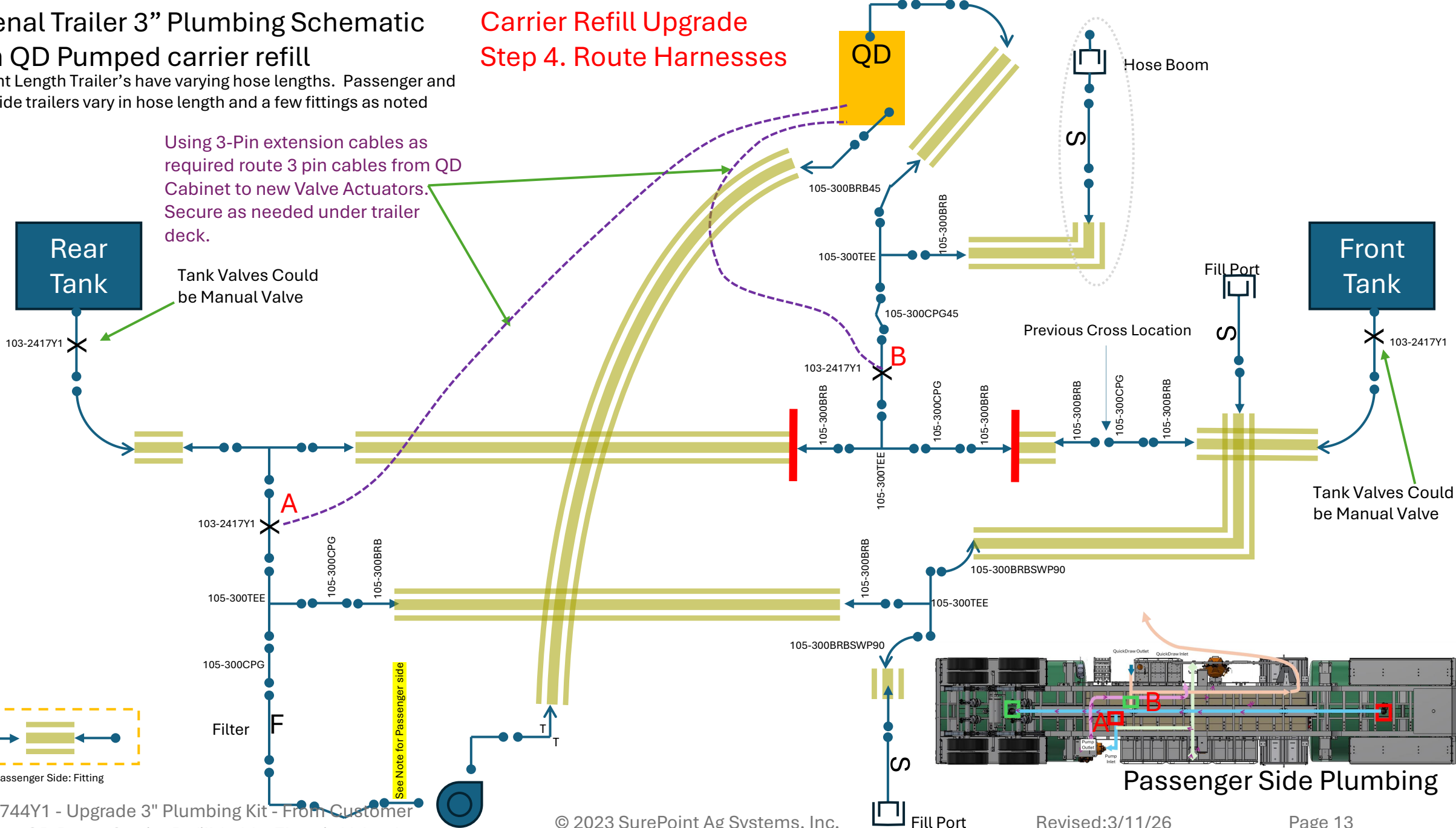

Passenger Side Plumbing

Arsenal Trailer 3" Plumbing Schematic with QD Pumped carrier refill

Different Length Trailer's have varying hose lengths. Passenger and driver side trailers vary in hose length and a few fittings as noted

Carrier Refill Upgrade Step 5. Finished Schematic

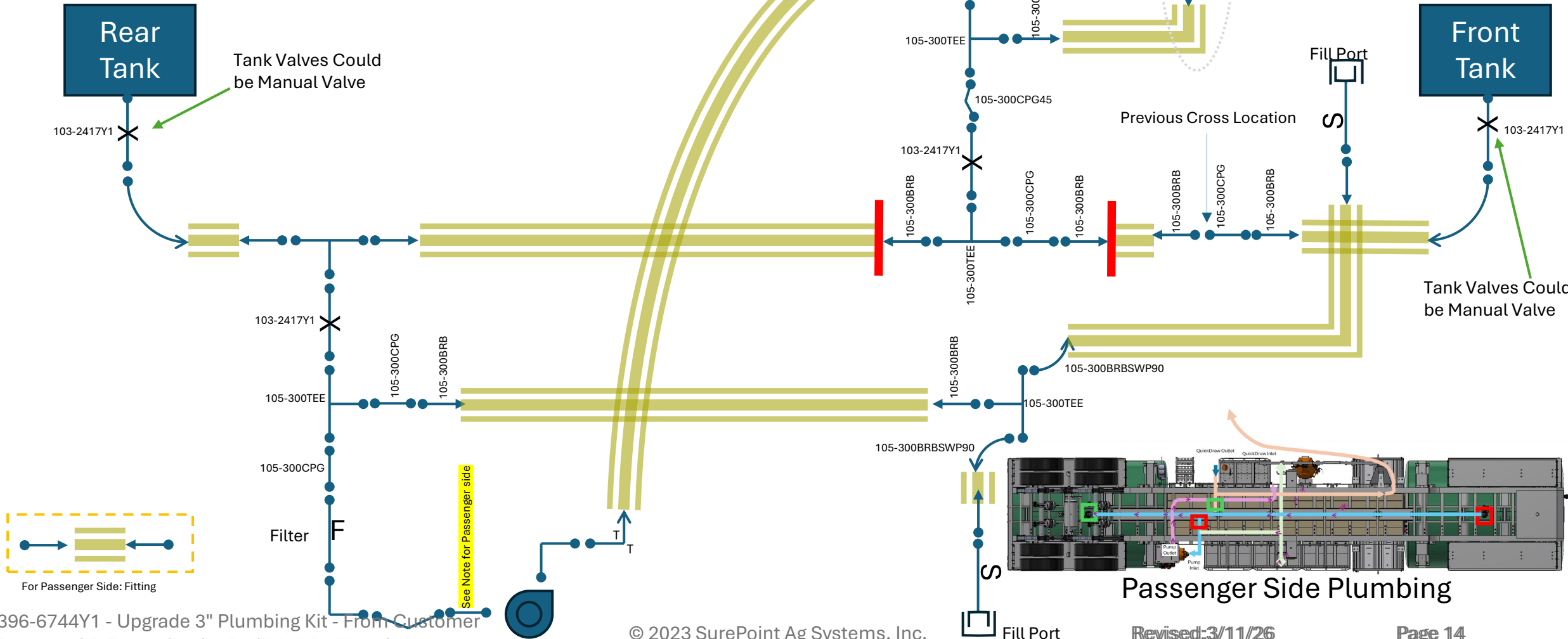

396-6744Y1 - Upgrade 3" Plumbing Kit - From Customer Pump to QD Pump Carrier Refill (add 2 Electric Valves)

Passenger and Driver Side Wiring Instructions

Electric Valve Harness Connection for trailers with existing electric tank valves

1. Within cabinet located 2 pin connects associated with harnesses of the switches to the front and rear tank. The two pin connectors of the existing switches will be in a daisy chain.
2. Connect the two new electric valve switch harnesses (208-05-6855Y1) joining both to the existing 2-pin connector daisy chain
3. Route the 3-Pin connectors from both switch harnesses out the harness routing holes in the bottom back of the cabinet and using 3-pin extension cables route 3pin cables to each of the new electric valves and connect 3pin connectors to valve connectors. Secure harness routing under the trailer deck
4. Install two new toggle switches in the existing Arsenal Switch plate to the right of the QD controller.
 - a. The Switch 3 spot in the plate is for the valve closest to the QD cabinet on the QD outlet and Sprayer fill hose.
 - b. The Switch 4 Spot in the plate is for the valve in the back on the pump filter branch. (Note the switch hole pattern for this switch makes the valve open when toggled down which is the opposite of the other 3 switch holes.)
5. Power up QD Controller, and cycle new valves to confirm proper operation.
 - a. Switch 3 should control the valve on the QD outlet hose and toggle up should be valve open and toggle down should be valve closed
 - b. Switch 4 should control the valve towards the rear on the Pump filter branch and toggle UP should be valve CLOSED and toggle DOWN should be valve OPEN

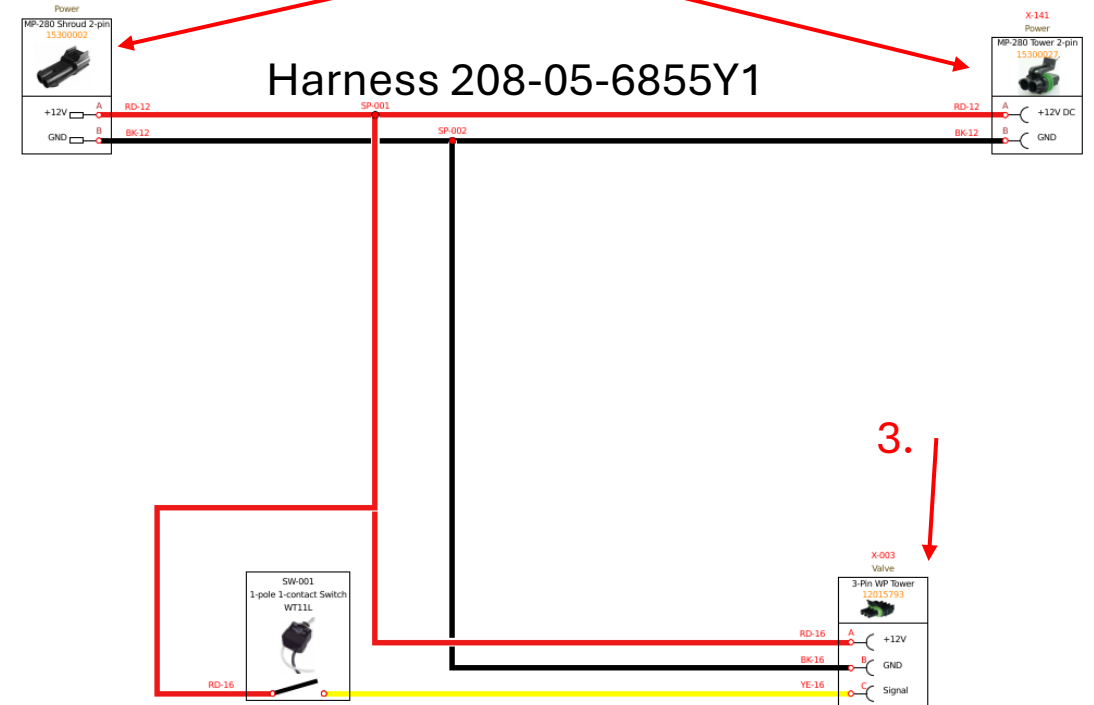
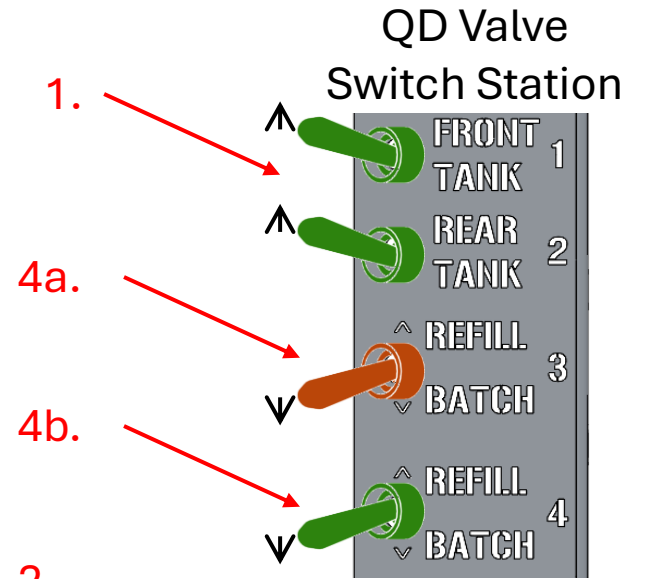

Electric Valve Harness Connection for trailers with no existing electric tank valves

- Within cabinet Locate 2 pin connection labeled pump power near battery on main Cabinet harness.
- Connect 2 pin connector on harness 208-05-4859Y3 to pump power connector. 4859Y3 harness is made to extend pump power to pump start/stop connector already using pump power connector.
- Within cabinet locate 3pin connector on main cabinet harness labeled modem power (usually under battery). Connect modem power connector from 4859Y3 harness to this connector. If modem power connector already in use this 4859Y3 harness is made to extend modem power to existing user (if needed)
- Connect the 2nd new electric valve switch harnesses (208-05-6855Y1) to 4859Y3 2-pin connector.
- Route the 3-Pin connectors from both switch harnesses out the harness routing holes in the bottom back of the cabinet and using 3-pin extension cables route 3pin cables to each of the new electric valves and connect 3pin cables to valve connectors. Secure harness routing under the trailer deck
- Install two new toggle switches in the existing Arsenal Switch plate to the right of the QD controller.
 - The Switch 3 spot in the plate is for the valve closest to the QD cabinet on the QD outlet and Sprayer fill hose.
 - The Switch 4 Spot in the plate is for the valve in the back on the pump filter branch. (Note the switch hole pattern for this switch makes the valve open when toggled down which is the opposite of the other 3 switch holes.)
- Power up QD Controller, and cycle new valves to confirm proper operation.
 - Switch 3 should control the valve on the QD outlet hose and toggle up should be valve open and toggle down should be valve closed
 - Switch 4 should control the valve towards the rear on the Pump filter branch and toggle UP should be valve CLOSED and toggle DOWN should be valve OPEN

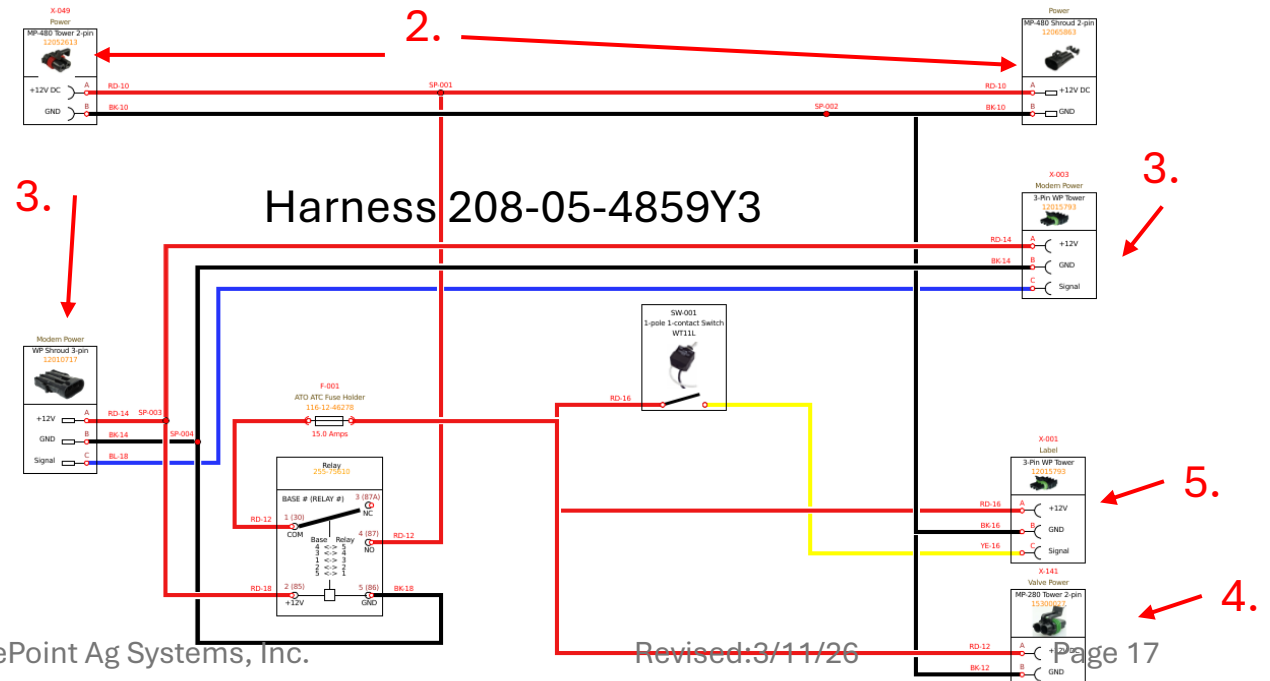
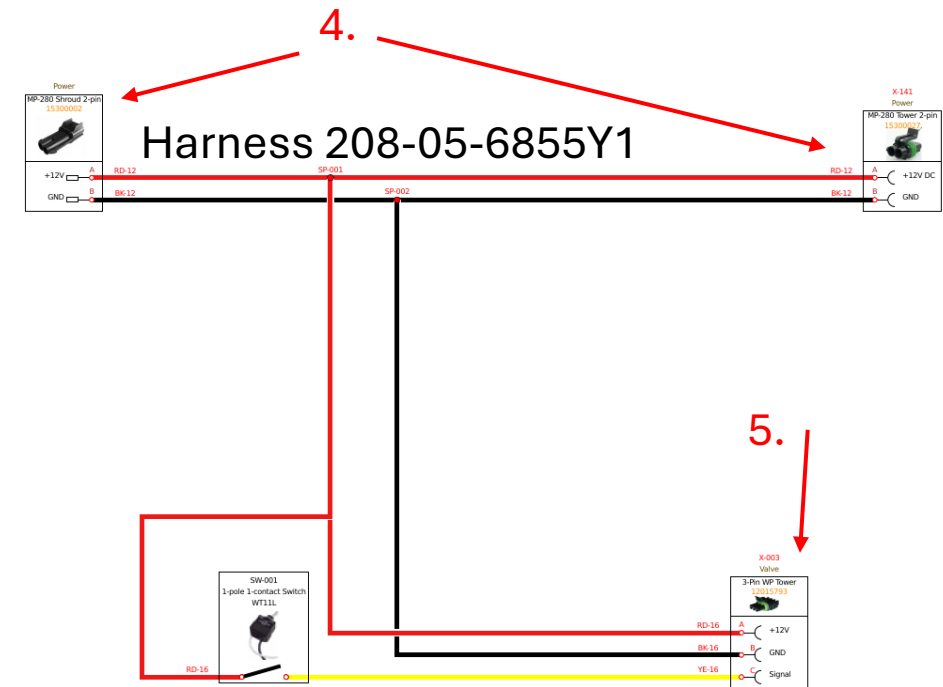
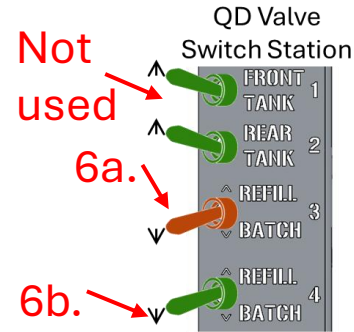

QuickDraw "Carrier Refill Option" Schematic

Batch Configuration

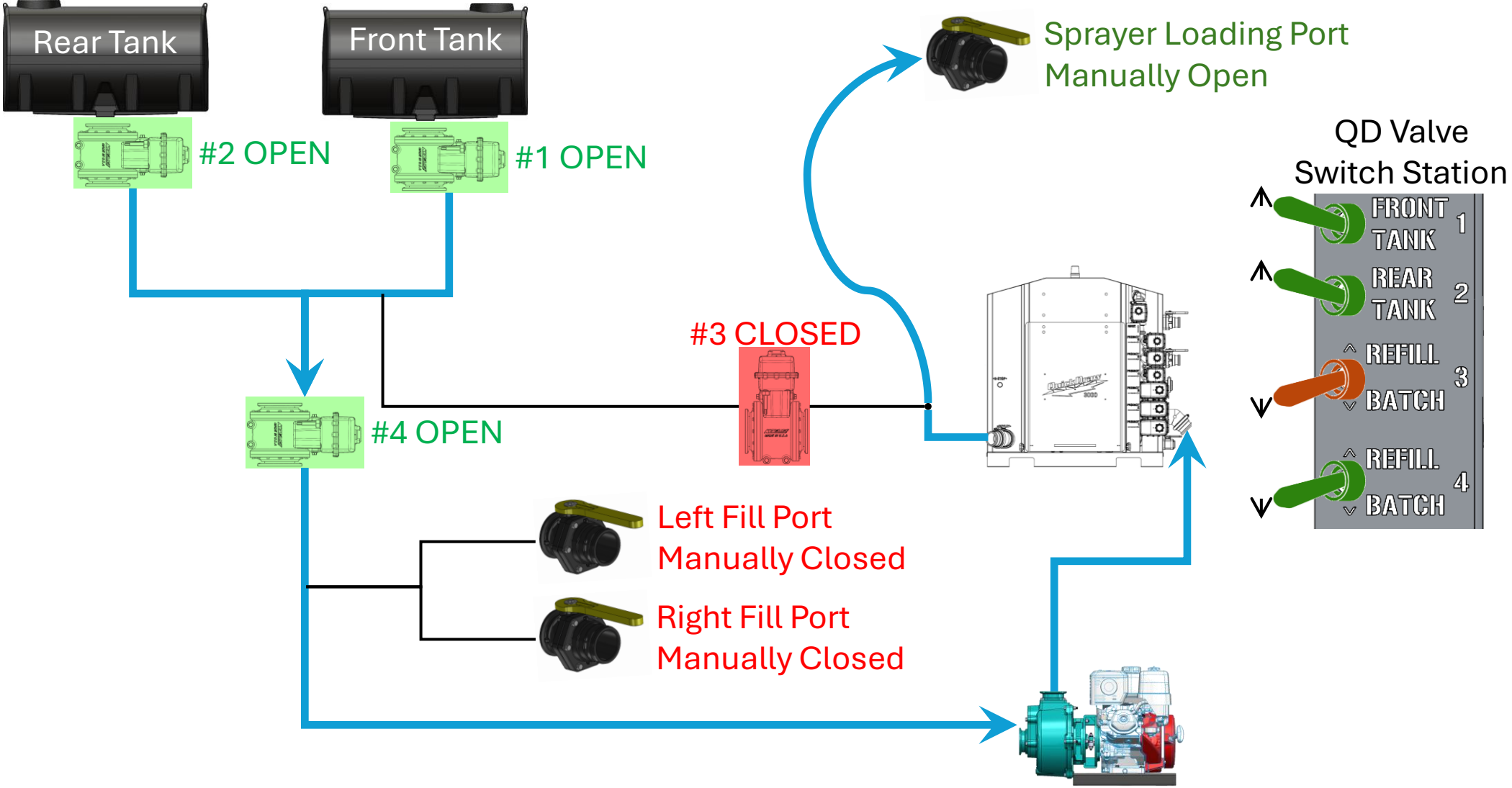

QuickDraw "Carrier Refill Option" Schematic

Refill Front Tank from Off-Trailer Pumped Source thru Left Fill Port Configuration

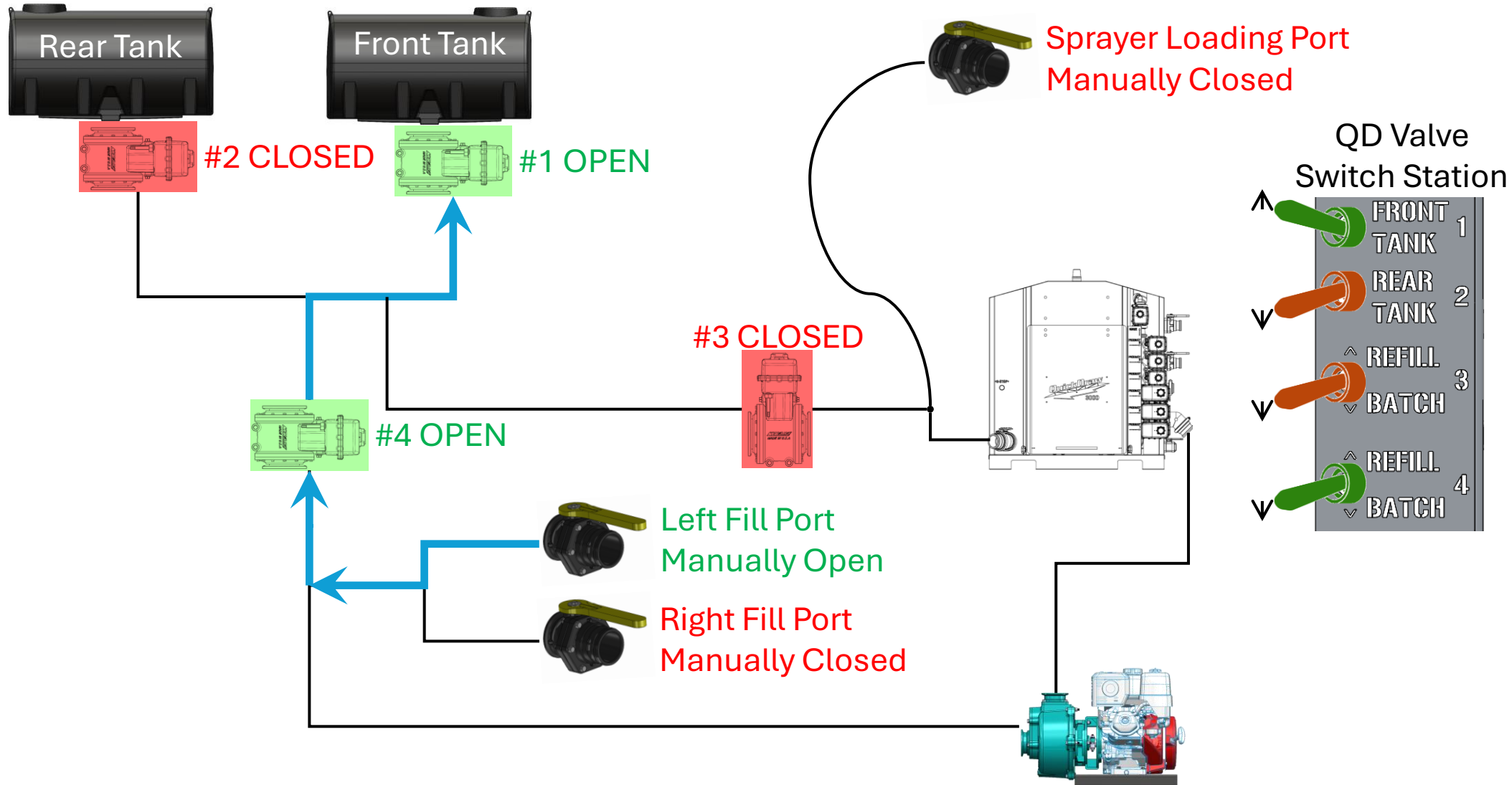

QuickDraw “Carrier Refill Option” Schematic

QuickDraw Refill Rear Tank, From Right Fill Port Configuration

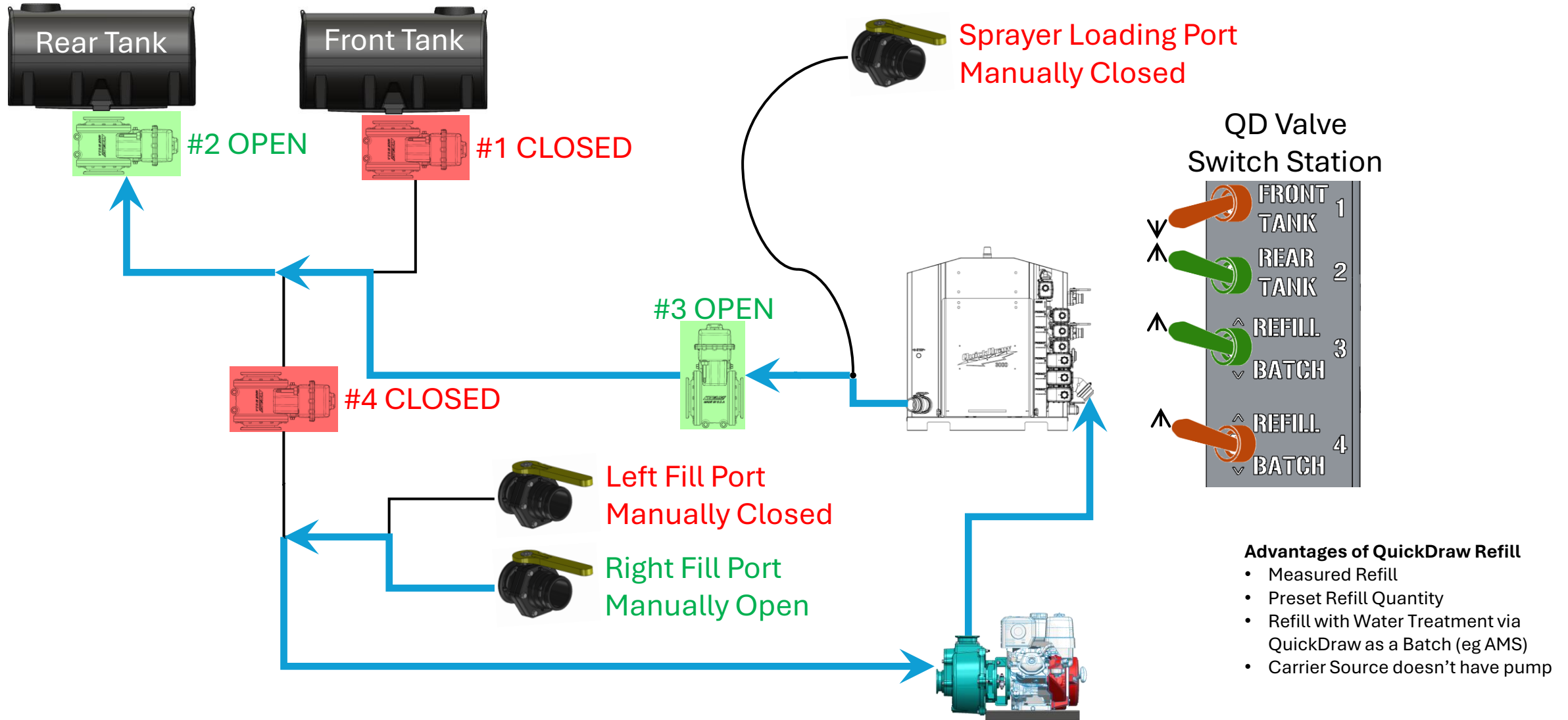

QuickDraw "Carrier Refill Option" Schematic

Batch Configuration- ERROR #1

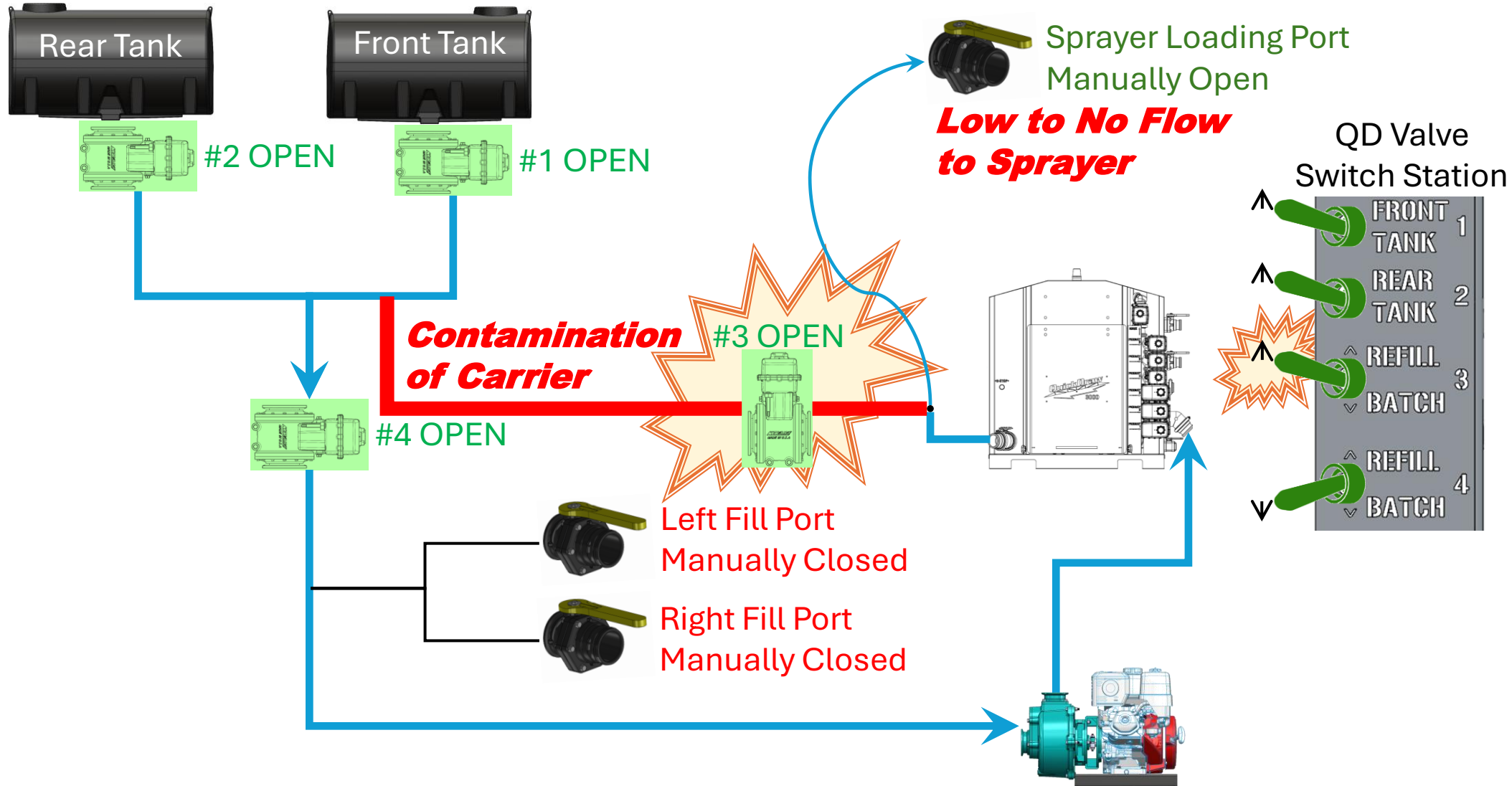

QuickDraw "Carrier Refill Option" Schematic

Batch Configuration-ERROR #2

