



# 396-5098Y1

*Great Plains* BD7600-30

## 400 Gallon Tank Mounting Instructions

Drill Manufacturer:



Kit Number: 551-04-300400

Description: Great Plains BD7600-30 400 Gallon Tank Kit

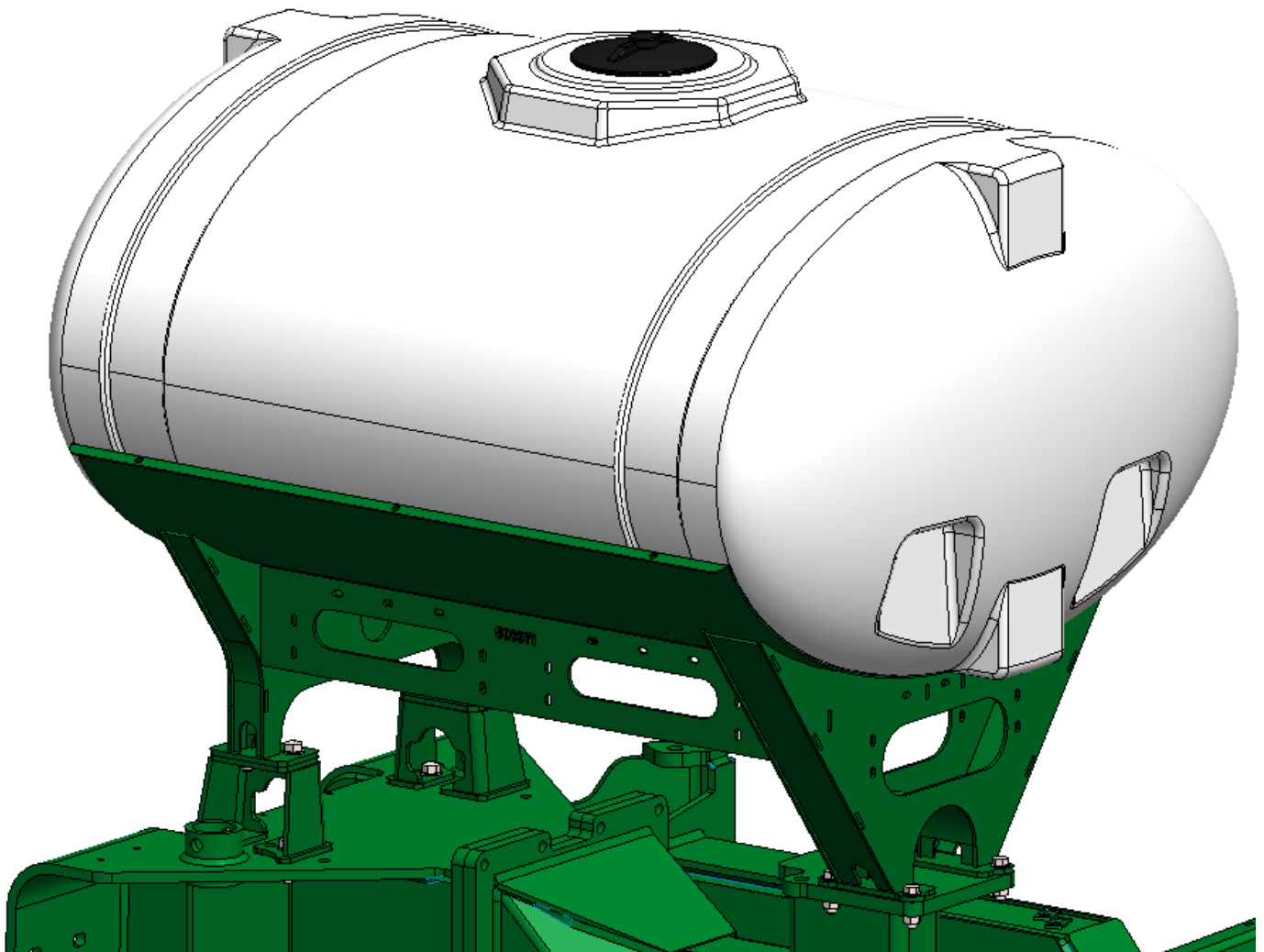



# Parts List and Installation Dimensions

## 551-04-300400

### 400 Gallon Elliptical Tank Kit

ITEM NO.	PART NUMBER	DESCRIPTION	QTY.
1	727-01-HE0400-57-W	Elliptical Tank - 400 Gal - White	1
2	450-5093Y1	Great Plains BD7600 26' 400 Gal Tank Bracket	1
3	300-100208-5	5/8" x 2-1/2" Hex Head Bolt - G5	4
4	300-120200-5	3/4" x 2" Hex Head Bolt - G5	4
5	300-120208-5	3/4" x 2-1/2" Hex Head Bolt - G5	4
6	323-10	5/8" Flange Nut	4
7	323-12	3/4" Flange Nut	8
8	330-10	5/8" Flat Washer	4
9	330-12	3/4" Flat Washer	8
10	525-3000	3" Tank Strap Kit for 400 - 500 Gallon Tanks	3
11	521-00-100285	Tank Overflow Assembly Bag for 400-750 Gal Tanks	1
12	280-100-AG200	1" AG200 Bulk	10'
13	450-5096Y2	Great Plains BD7600 30 Foot - Pedestal - Y2	1
14	450-7782Y1	Great Plains BD7600 30 Foot - Pedestal - RIGHT	1

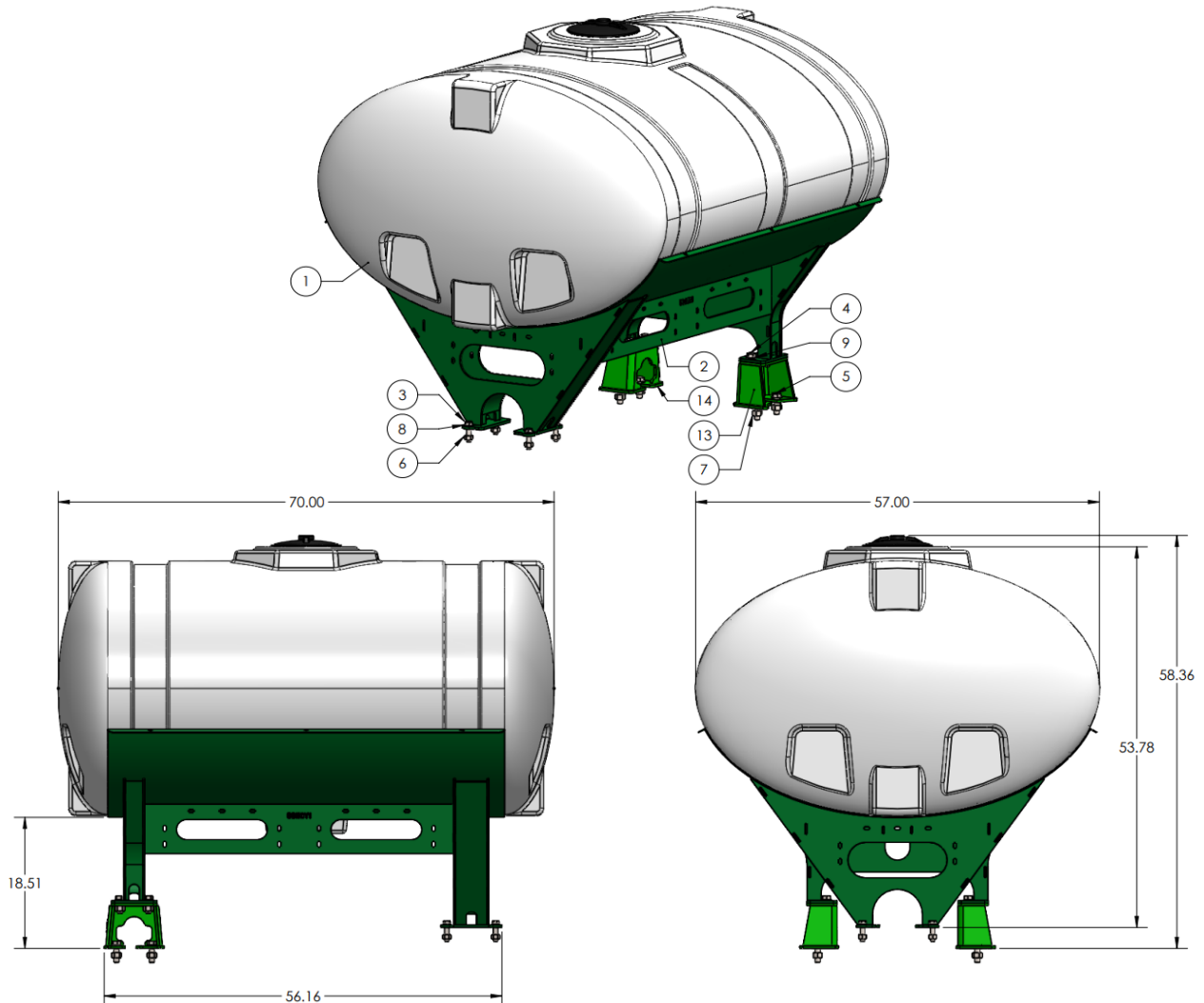



# Step by Step Instructions

1. Loosely mount both Left and Right pedestals to the bolt plate on the hitch using four (4) 3/4" x 2-1/2" hex head bolts, washers, and flange nuts. Install edge guard and check hydraulic hoses for clearance and rubbing. Re-secure or reroute hydraulic hoses as needed.

Step 1

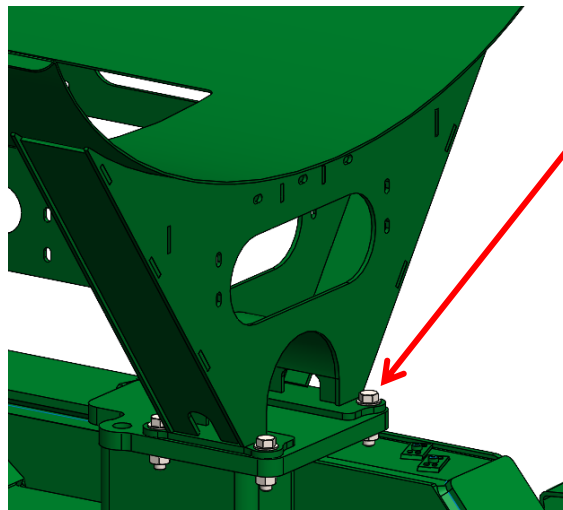
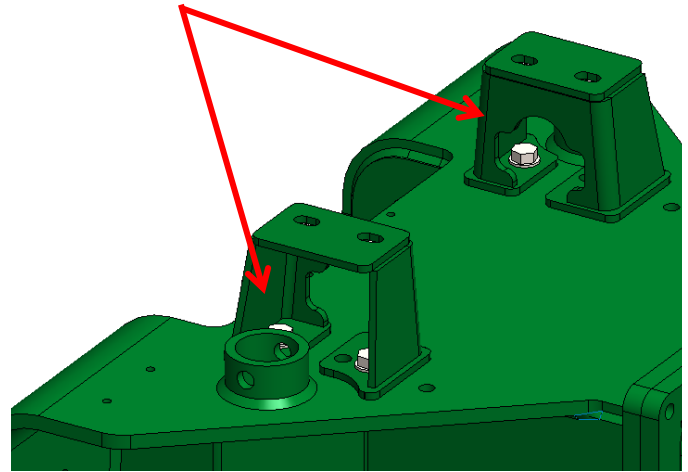

Step 2

2. Loosely mount the front of 450-5093Y1 - 400 Gallon Tank Bracket to the bolt plate on the hitch using four (4) 5/8" x 2-1/2" hex head bolts, washers, and flange nuts.

3. Loosely mount the back of 450-5093Y1 - 400 Gallon Tank Bracket to both pedestals to the bolt plate on the hitch using four (4) 3/4" x 2-1/2" hex head bolts, washers, and flange nuts.

Step 3

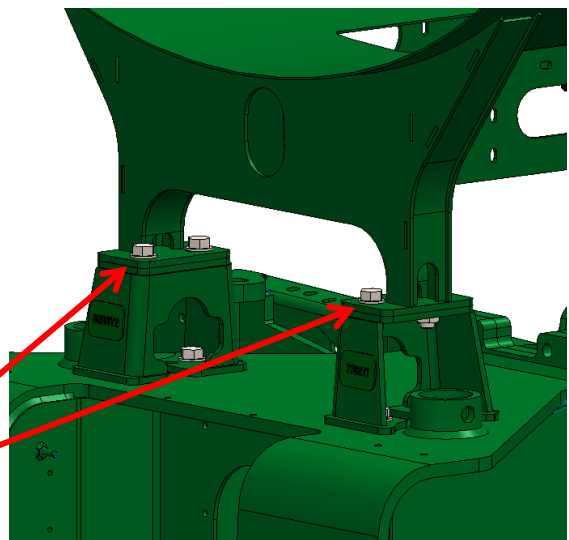



# Step by Step Instructions

4. Once bolts and holes line up, tighten all mounting bracket bolts.

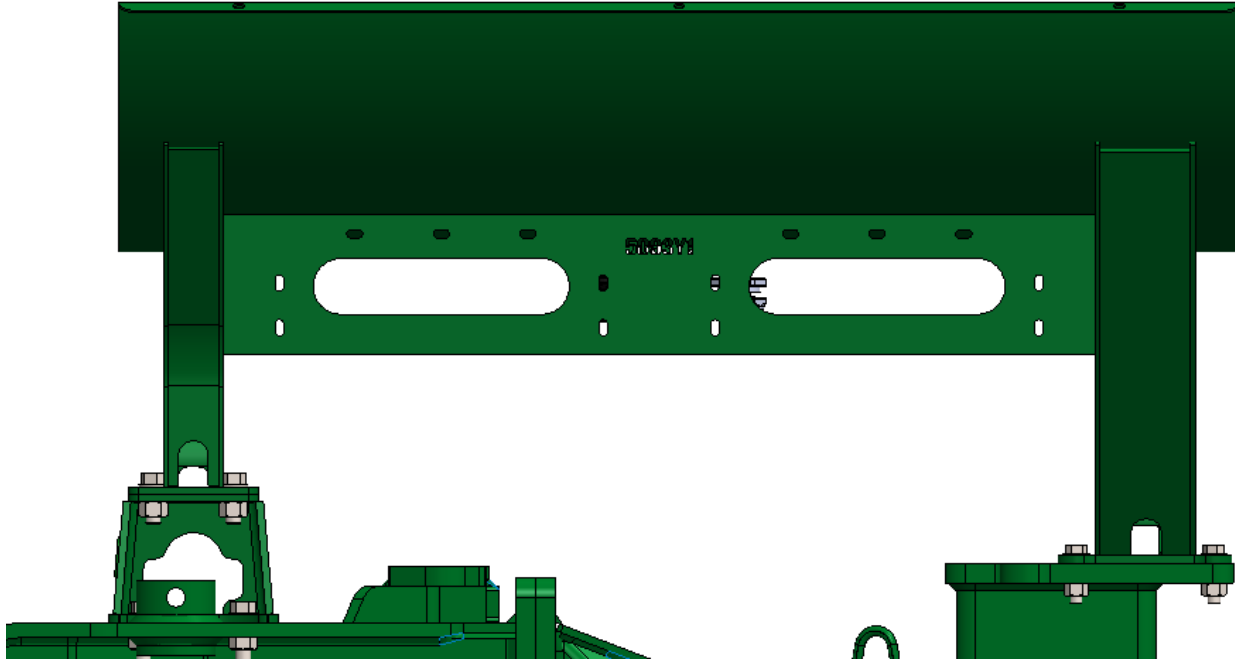

5. Finally, install the tank in the saddles and fasten the tank strap mounting brackets, and tank straps. Check for clearance from seed boxes when folding and when the drill is raised and lowered. Note: Tighten straps again once the tank has been filled.

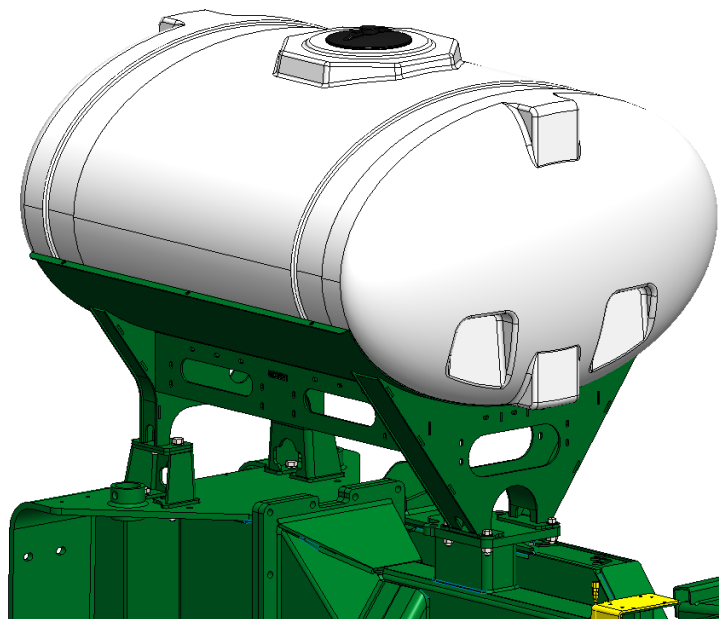



# Suggested Items

**Kit Number: 515-03-203500**

**Kit Description: Great Plains Gauge Extension / Section Valve Bracket**

ITEM NO.	PART NUMBER	DESCRIPTION	QTY.
1	300-050100-5	5/16" x 1" Hex Head Bolt - G5	2
2	323-05	5/16" Flange Nut	2
3	330-05	5/16" Flat Washer	2
4	380-1013	1/2" U-bolt Kit - fits 6" x 18" tube - (6" opening) includes flange nuts	2
5	380-1036	1/2" U-bolt Kit - fits 6" x 12" tube - (6" opening) includes flange nuts.	2
6	400-5163Y1	Great Plains Gauge Extension / Section Valve Mounting Bracket	1

*Note: Not all U-bolts will be used.*

1. Mount 400-5163Y1 bracket on hitch as shown, using two (2) 6" x 12" U-bolts and flange nuts in kit 380-1013.
2. Mount the gauge bracket to 400-5163Y1 as shown, using two (2) 5/16" x 1" hex head bolts, washers, and flange nuts.

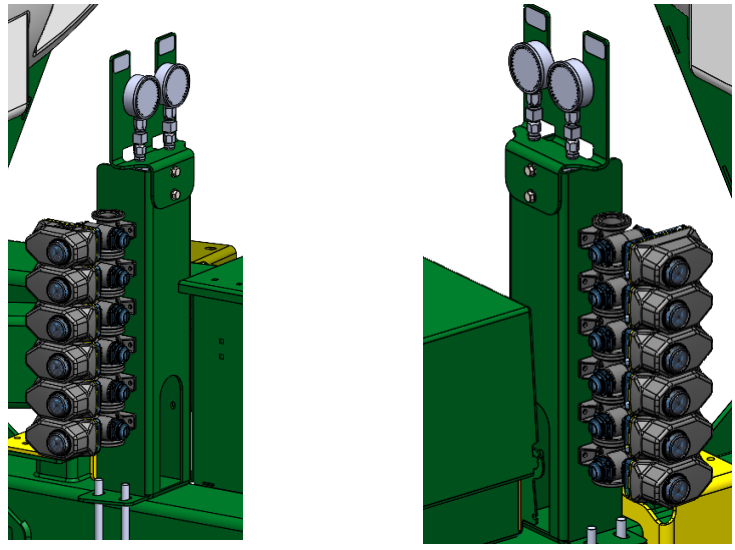
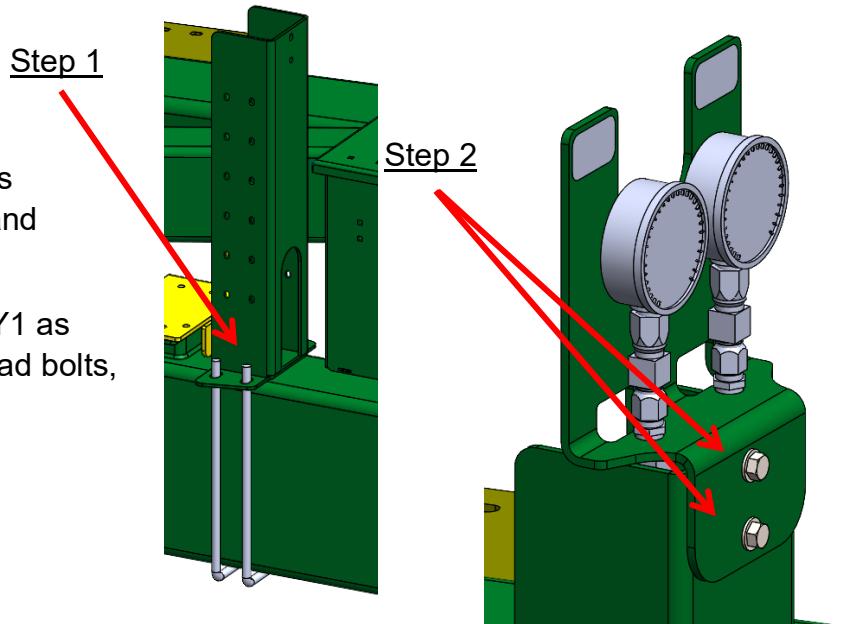

*Section Valve options with Great Plains Tank.*



# Suggested Items

Kit Description: Great Plains Tower/PumpRight Side of Cradle Mounting Kit

Kit Number: 515-03-203400

ITEM NO.	PART NUMBER	DESCRIPTION	QTY.
1	300-060108-5	3/8" x 1-1/2" Hex Head Bolt - G5	7
2	300-080108-5	1/2" x 1-1/2" Hex Head Bolt - G5	4
3	323-06	3/8" Flat Washer	7
4	323-08	1/2" Flange Nut	4
5	330-06	3/8" Flat Washer	7
6	330-08	1/2" Flat Washer	4
7	384-1080	Hardware Kit - Qty 4 of 3/8" Carriage Bolts	1
8	400-4996Y1-GN	Great Plains Side of Cradle Tower/PumpRight Mounting Bracket	1

## Mounting Instructions:

1. Mount 400-4996Y1 pump mounting bracket to the front or either side of BD7600 26 Foot 400 Gallon Tank Mount (450-5093Y1) using seven (7) 3/8" x 1-1/2" hex head bolts, washers, and flange nuts.
2. Mount Tower/PumpRight using the hardware provided in kit.

### Step 1

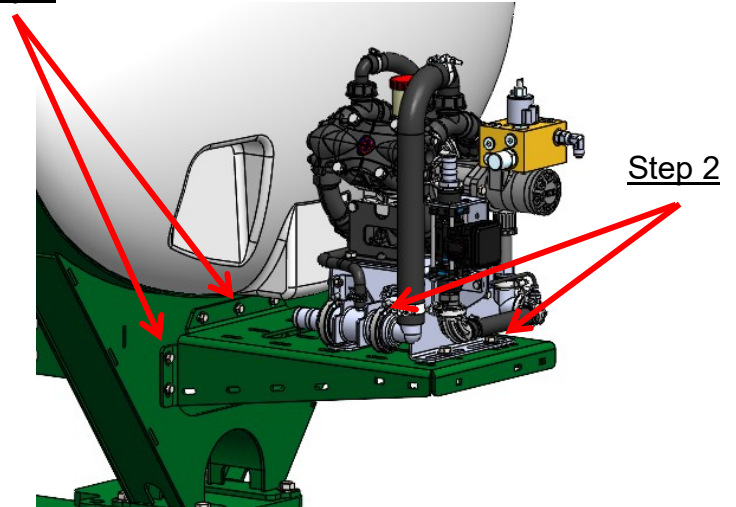

*Orientation of pump may vary from shown.*

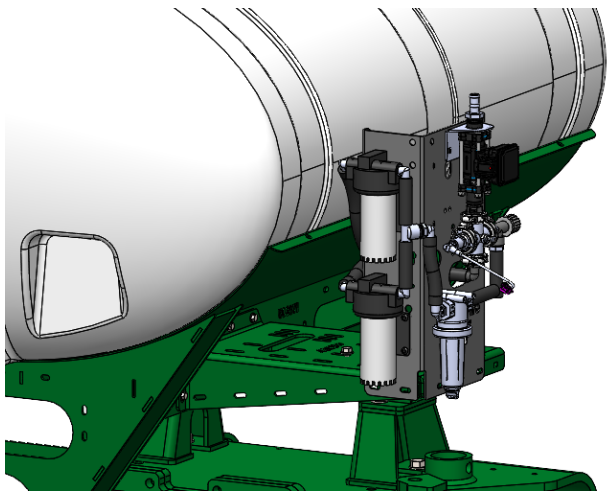



# Suggested Items

## Kit Description: Great Plains BD7600 Tower Mounting Kit

Kit Number: 511-1012

ITEM NO.	PART NUMBER	DESCRIPTION	QTY.
1	410-4213Y1	Great Plains BD7600 Series Drill Tower	1
2	380-1036	1/2" U-Bolt Kit - Fits 6" x 12" Tube	2
3	380-1013	1/2" U-Bolt Kit - Fits 6" x 18" Tube	2
4	384-1080	Hardware Kit - Qty 4 of 3/8" Flange nuts for	1

### Tower Mounting Instructions:

1. Mount 410-4213Y1 on hitch between toolbox and tank using hardware provided in 380-1036 or 380-1013.
2. Mount Tower on front face of 410-4213Y1 bracket using hardware provided in kit 384-1080 as shown.

### Step 1

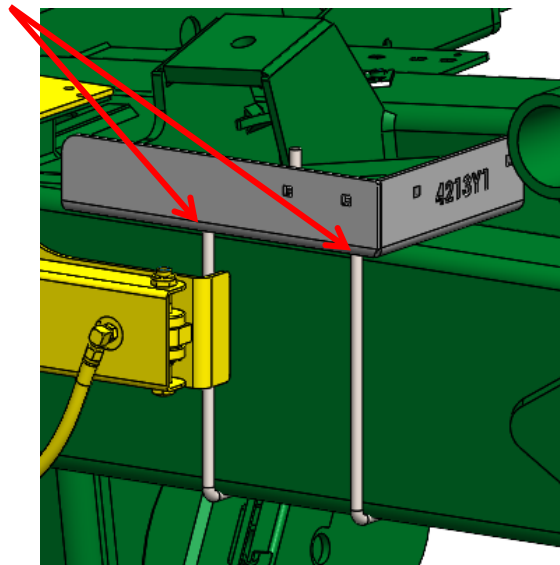

### Step 2

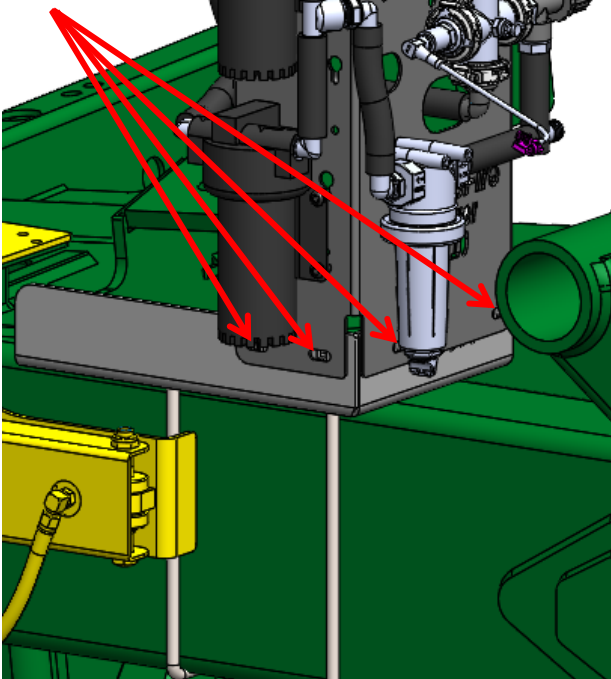



# BD7600 Fill/Discharge Kit

Kit Number: 555-101450

Kit Description: Great Plains BD7600 Series Drill 1-1/2" Fill/Discharge Kit (Tower)

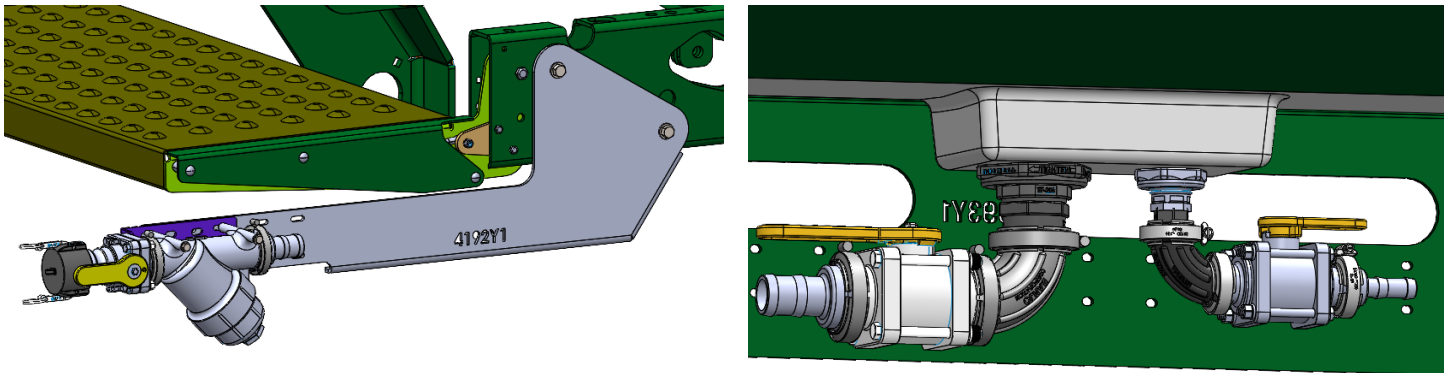

Note: Not all parts may be used.

ITEM NO.	PART NUMBER	DESCRIPTION	QTY.
1	102-200MVCF	2" Manifold Standard Port Poly Valve	1
2	102-100MVCF	1" Manifold Full Port Poly Valve	1
3	102-200VSFCF	200 Series Manifold x 2" Male Quick Coupler Standard Port Poly Valve	1
4	105-100075BRB	1" Manifold x 3/4" HB	1
5	105-100075MPT	1" Manifold x 3/4" MPT	1
6	105-100SWP90	1" Manifold Sweep - 90 Degree	1
7	105-100G-H	1" EPDM Manifold Gasket	3
8	105-150G-H	1-1/2" EPDM Manifold Gasket for 200 Series Manifold fittings	6
9	105-200100CPG	2" Manifold x 1" - Reducer Coupling	1
10	105-200100TEE	2" Manifold x 1" Manifold Tee	1
11	105-200125MPT	2" Manifold x 1-1/4" MPT	1
12	105-200MPT	2" Manifold x 2" MPT	2
13	105-200SWP90	2" Manifold Sweep - 90 Degree	1
14	105-FC100	1" Manifold Clamp	3
15	105-FC200	2" Manifold Clamp	6
16	106-200CAP	2" Cap	1
17	109-200MLS-20M	2" Manifold Y Strainer - 20 Mesh w/ 5/16" bolt holes for mounting	1
18	280-150-ENF	1-1/2" Enforcer Fertilizer Solution Hose	20
19	300-050100-5	5/16" x 1" Hex Head Bolt - G5	2
20	300-050600-5	5/16" x 6" Hex Head Bolt - G5	2
21	300-080408-5	1/2" x 4-1/2" Hex Head Bolt - G5	2
22	321-08	1/2" Nylock Nut	2
23	323-05	5/16" Flange Nut	2
24	330-05	5/16" Flat Washer	4
25	330-08	1/2" Flat Washer	4
26	350-TC181	Pressure Seal HD Clamp, Size 238 (fits 1 1/4" - 1 1/2" Enforcer, Wire Braided or AG200)	2
27	400-2605Y1-BK	Universal Fill Kit Strainer/ Valve Mount bracket - Black	1
28	450-4192Y1-GN	Fill Kit Bracket - Great Plains Drill	1

# Step by Step Instructions

## Fill Kit Strainer Assembly

1. Mount 410-4192Y1 bracket to the outside right portion of the center box on the holes as shown, using two (2) 1/2" x 4-1/2" hex head bolts, washers, and flange nuts.
2. Mount the male quick coupler valve to the 400-2605Y1 bracket by removing the nuts and lock washers on the valve and re-assembling.
3. Mount the 400-2605Y1 and strainer assembly to the 410-4192Y1 - Fill Kit bracket using two (2) 5/16" x 6" hex head bolt, washers, and flange nuts.
4. Assemble the rest of the plumbing fittings as shown and route hose to tank valve assembly.

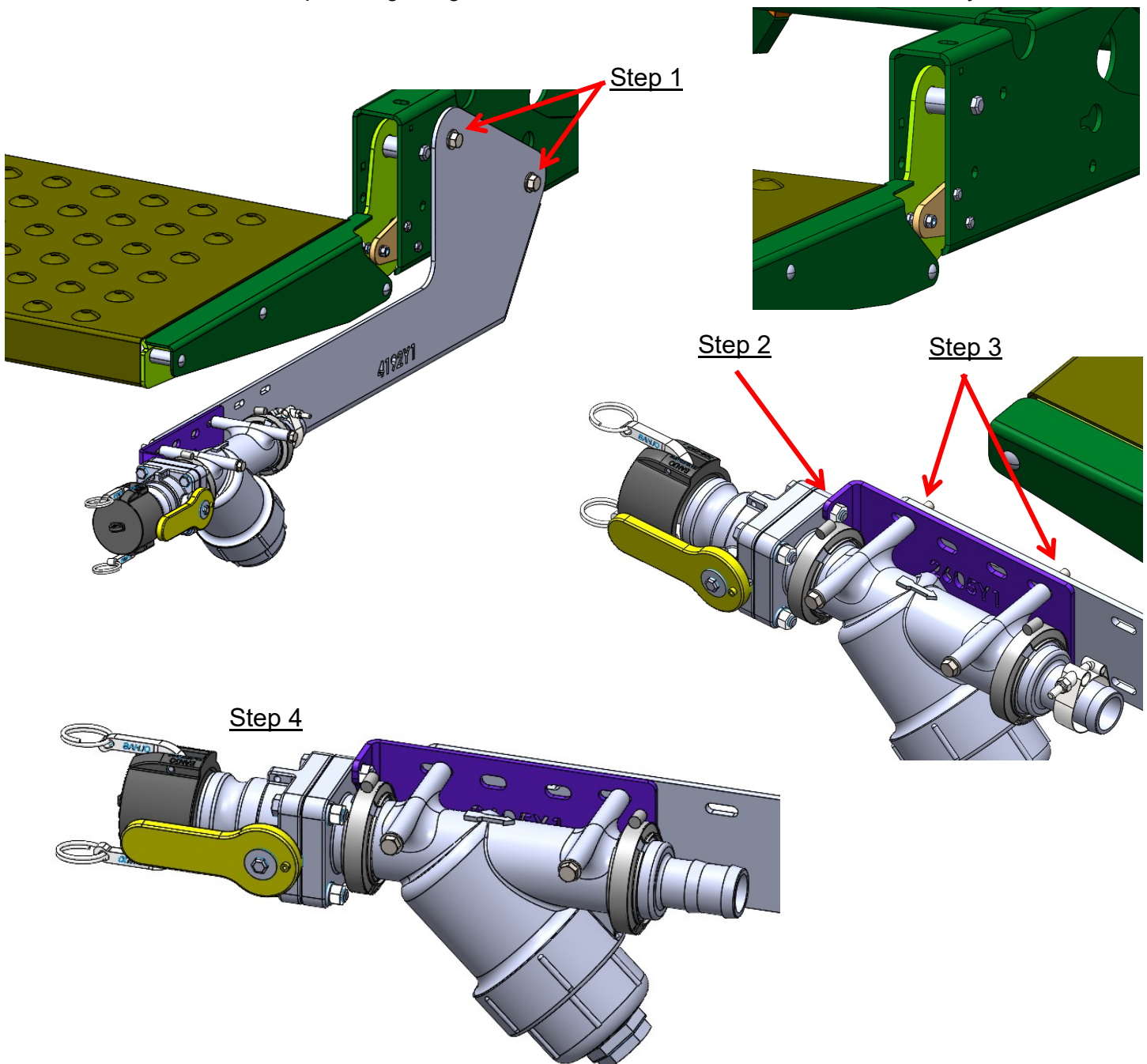

# Step by Step Instructions

## Tank Valve / Discharge Assembly - For SurePointTank & Tower

1. Thread the correct size manifold flange x MPT fitting into the bottom of the tank.
2. Assemble plumbing fittings as shown, using manifold clamps and gaskets.
3. Route 1-1/2" hose from the tank to the fill kit strainer assembly and 3/4" discharge hose from the tank to the Tower located in front of the tank, check for fold clearance and secure as necessary.

Step 1

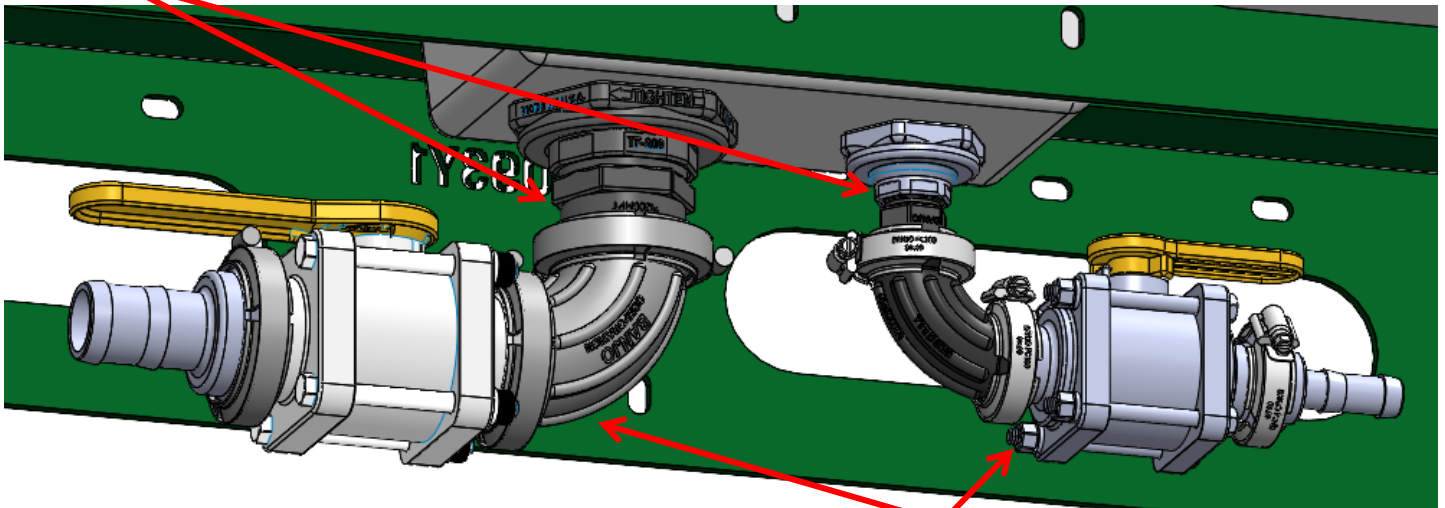

Step 2

Step 3

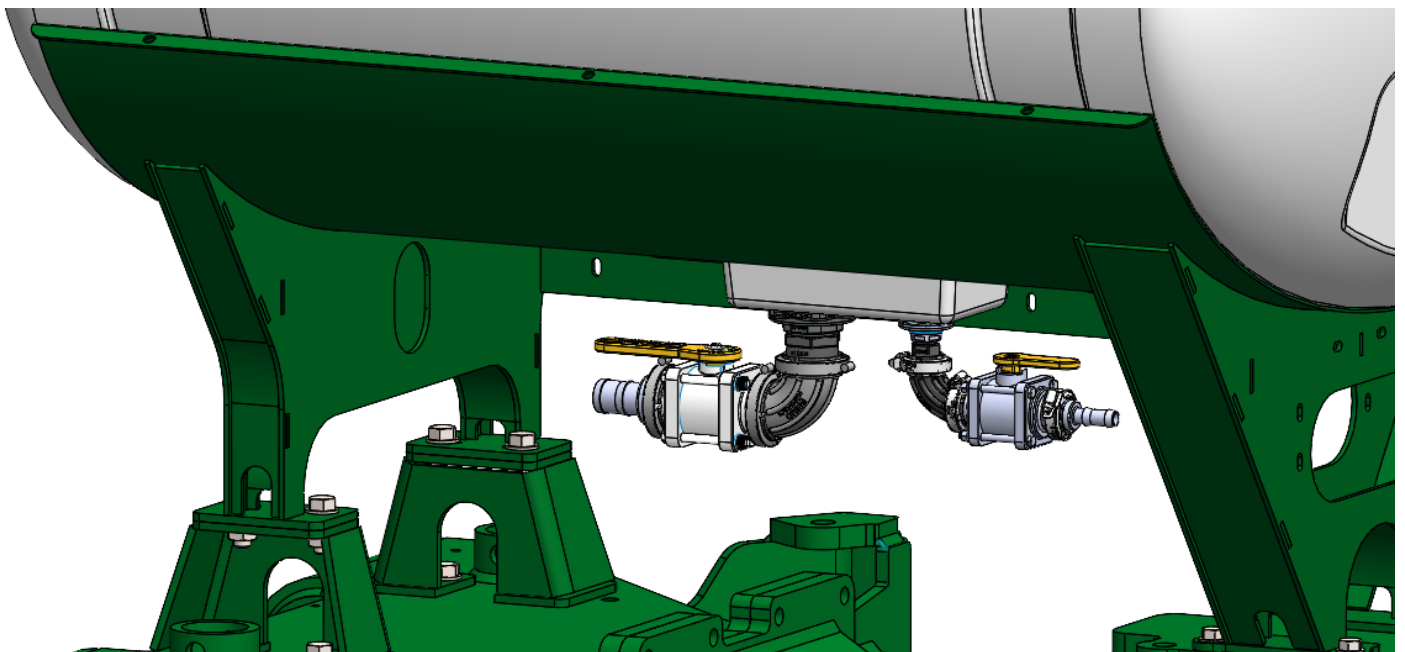

# Step by Step Instructions

## Tank Valve / Discharge Assembly - For Great Plains Tank & Tower

1. Thread the correct size manifold flange x MPT fitting into the bottom of the tank.
2. Assemble plumbing fittings as shown, using manifold clamps and gaskets.
3. Route 1-1/2" hose from the tank to the fill kit strainer assembly and 3/4" discharge hose from the tank to the Tower located in front of the tank. Check for fold clearance and secure as necessary.

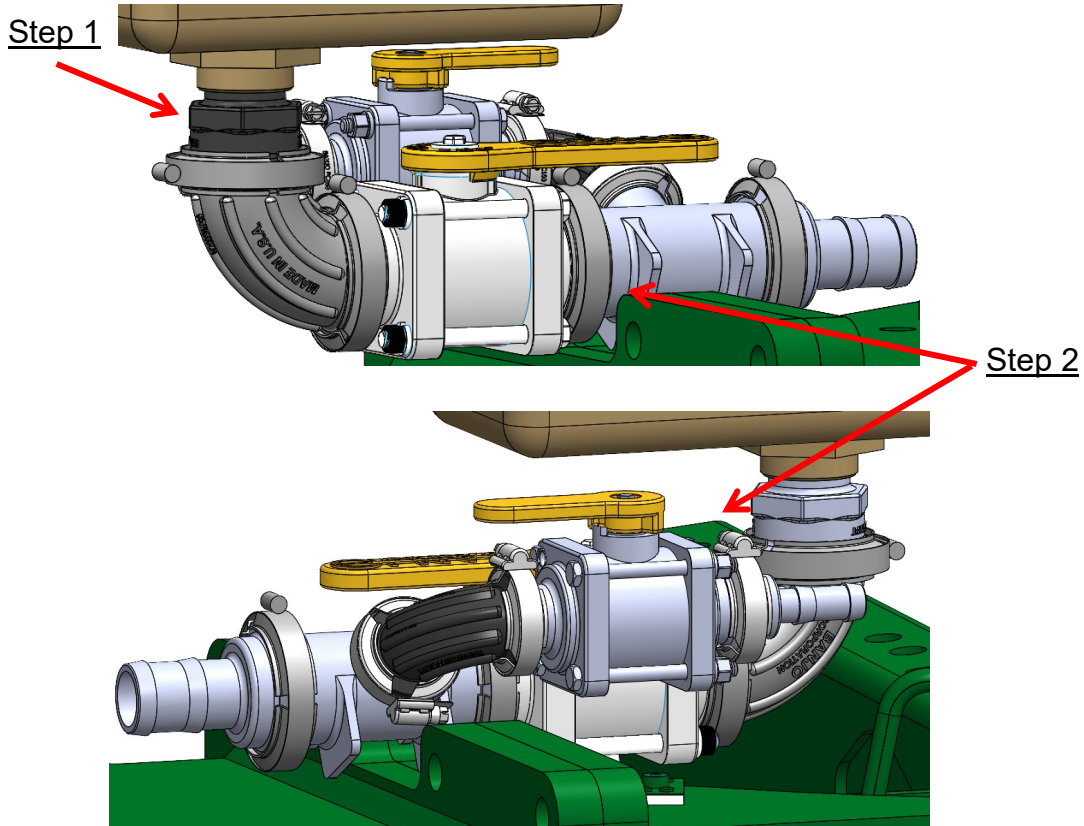

### Step 3

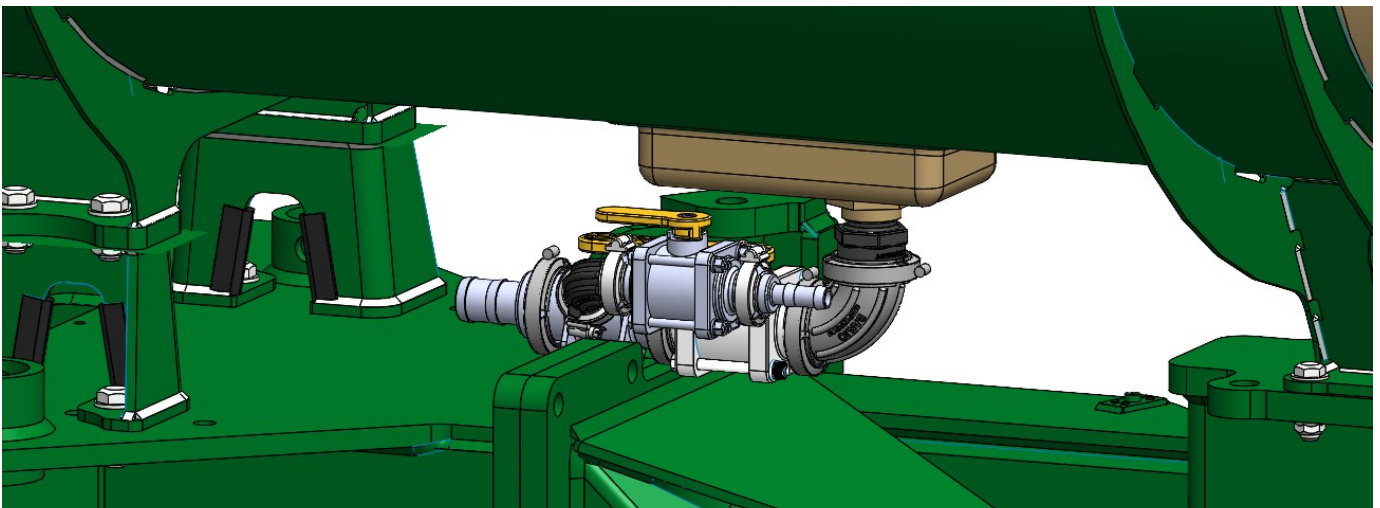



# BD7600 Fill/Discharge Kit

Kit Number: 555-101475

Kit Description: Great Plains BD7600 Series Drill 1-1/2" Fill/Discharge Kit (PumpRight)

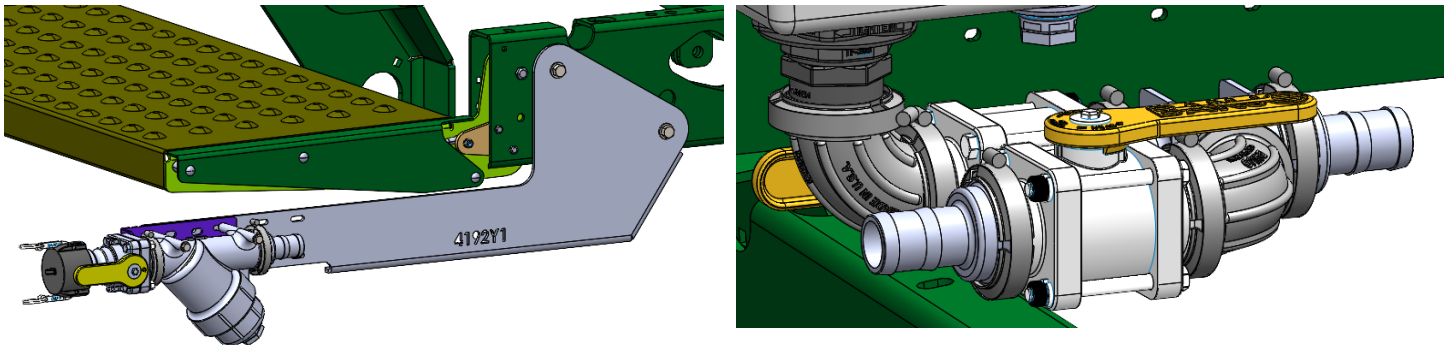

Note: Not all parts may be used.

ITEM NO.	PART NUMBER	DESCRIPTION	QTY.
1	100-075PLUG	3/4" Pipe Plug	1
2	102-200MVCF	2" Manifold Standard Port Poly Valve	2
3	102-200VSFCF	200 Series Manifold x 2" Male Quick Coupler Standard Port Poly Valve	1
4	105-150G-H	1-1/2" EPDM Manifold Gasket for 200 Series Manifold fittings	9
5	105-200125BRB	2" Manifold x 1-1/4" HB	1
6	105-200125MPT	2" Manifold x 1-1/4" MPT	1
7	105-200150BRB	2" Manifold x 1-1/2" HB	3
8	105-200MPT	2" Manifold x 2" MPT	2
9	105-200SWP90	2" Manifold Sweep - 90 Degree	2
10	105-200TEE	2" Manifold Tee	1
11	105-FC200	2" Manifold Clamp	9
12	106-200CAP	2" Cap	1
13	109-200MLS-20M	2" Manifold Y Strainer - 20 Mesh w/ 5/16" bolt holes for mounting	1
14	280-150-ENF	1-1/2" Enforcer Fertilizer Solution Hose	20
15	300-050100-5	5/16" x 1" Hex Head Bolt - G5	2
16	300-050600-5	5/16" x 6" Hex Head Bolt - G5	2
17	300-080408-5	1/2" x 4-1/2" Hex Head Bolt - G5	2
18	321-08	1/2" Nylock Nut	2
19	323-05	5/16" Flange Nut	2
20	330-05	5/16" Flat Washer	4
21	330-08	1/2" Flat Washer	4
22	350-TC181	Pressure Seal HD Clamp, Size 238 (fits 1 1/4" - 1 1/2" Enforcer, Wire Braided or AG200)	2
23	400-2605Y1-BK	Universal Fill Kit Strainer/ Valve Mount bracket - Black	1
24	450-4192Y1-GN	Fill Kit Bracket - Great Plains Drill	1



# Step by Step Instructions

## Tank Valve / Discharge Assembly - For SurePointTank & PumpRight

1. Thread the correct size manifold flange x MPT fitting into the bottom of the tank. Plug opening not in use.
2. Assemble plumbing fittings as shown, using manifold clamps and gaskets.
3. Route 1-1/2" hose from the tank to the fill kit strainer assembly and 1-1/4" or 1-1/2" discharge hose from the tank to the PumpRight located in front of the tank. Check for fold clearance and secure as necessary.

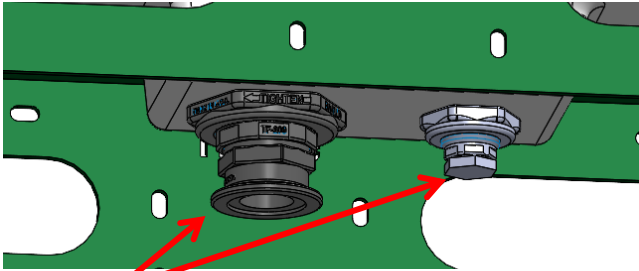

Step 1

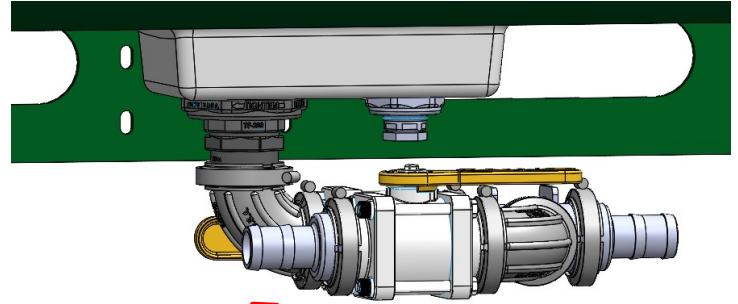

Step 2

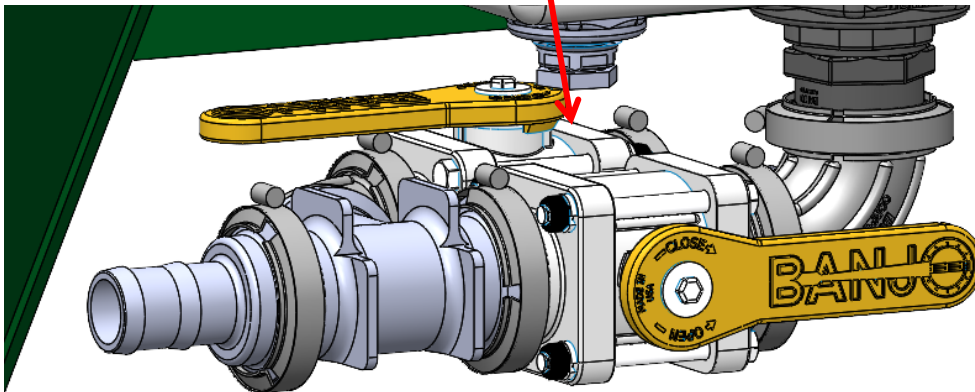

Step 3

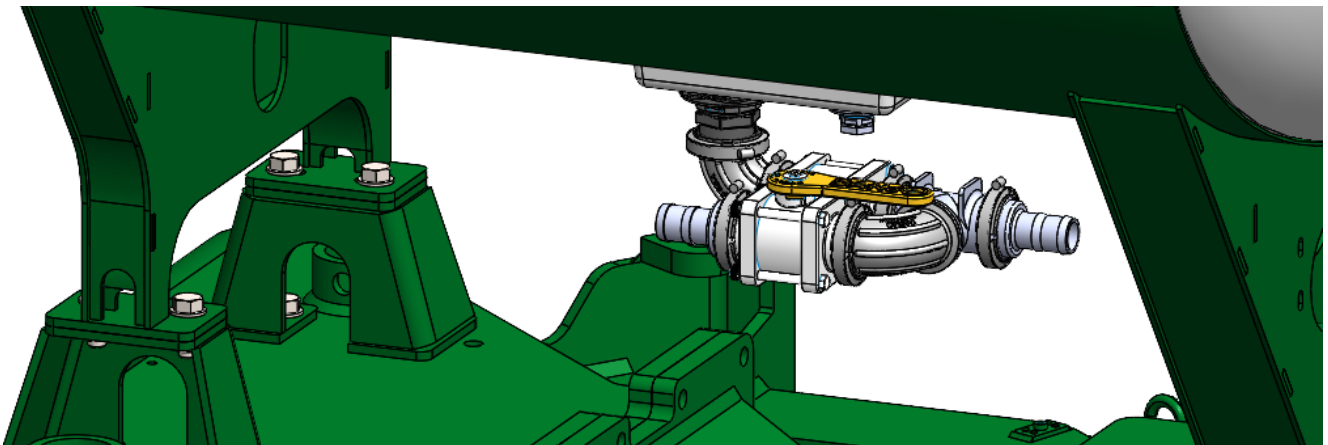

# Step by Step Instructions

## Tank Valve / Discharge Assembly - For Great Plains Tank & PumpRight

1. Thread the correct size manifold flange x MPT fitting into the bottom of the tank.
2. Assemble plumbing fittings as shown, using manifold clamps and gaskets.
3. Route 1-1/2" hose from the tank to the fill kit strainer assembly and 1-1/4" or 1-1/2" discharge hose from the tank to the Tower located in front of the tank. Check for fold clearance and secure as necessary.

Step 1

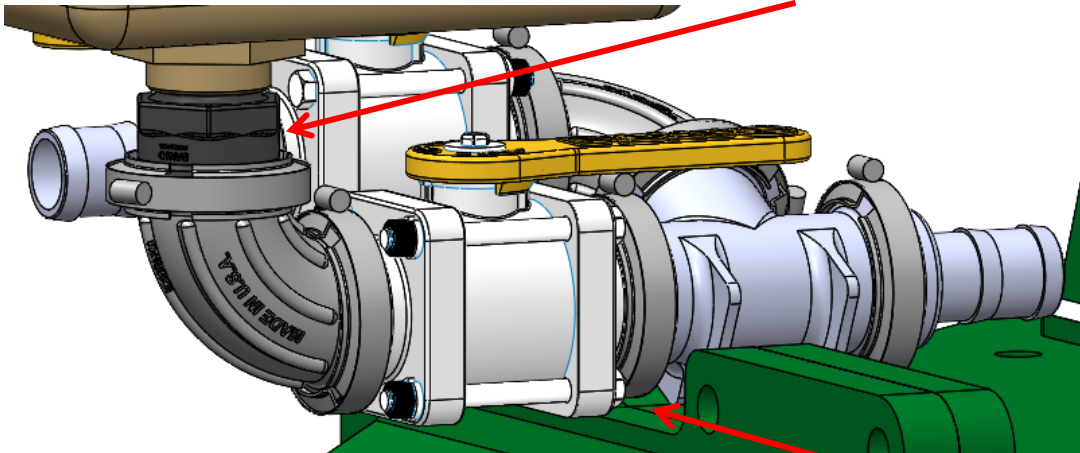

Step 2

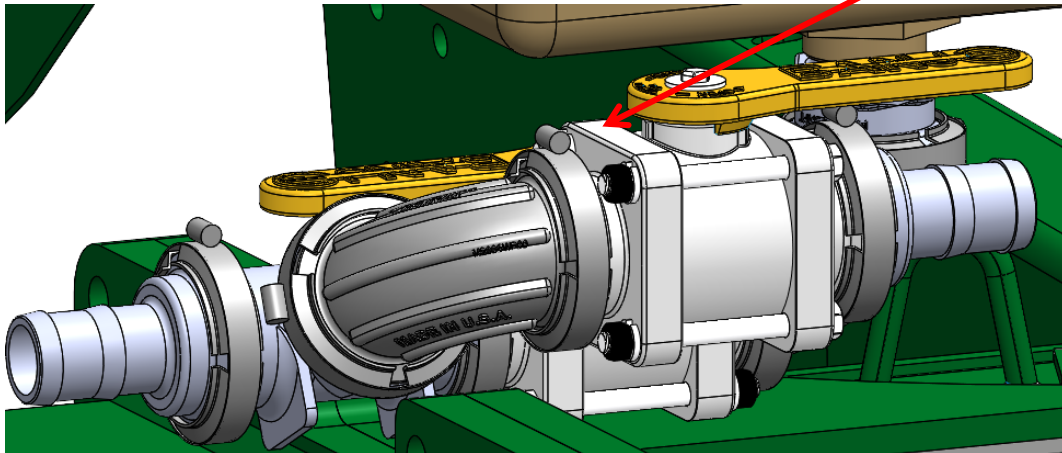

Step 3

