

396-001060



**Tower Electric Pump
Fertilizer System for
John Deere
GreenStar Rate Controller
GRC**

JOHN DEERE GRC

&

Tower for PWM Control

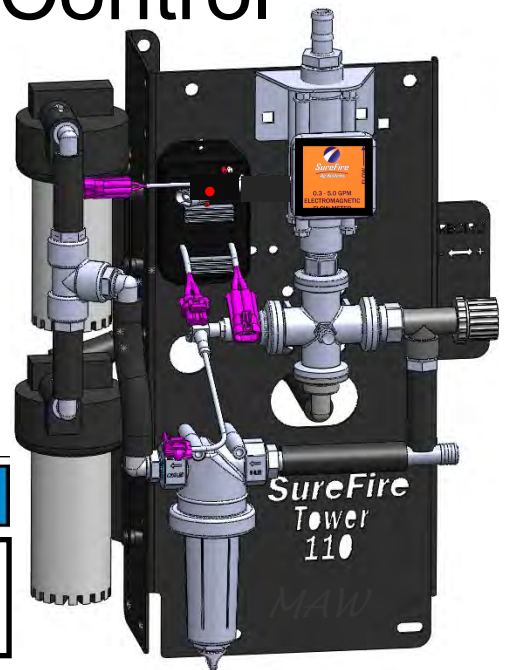
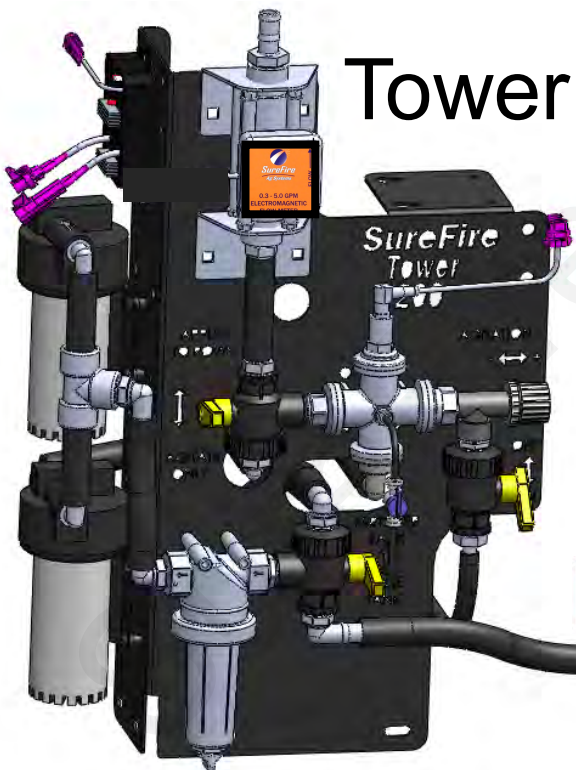

NOTICE

Operator should read this manual before operating the system.

Maximum Application Rates with Two 5.3 GPM Electric Pumps

Maximum Application Rates in GPA on 30" Rows at 6 MPH (no agitation)				
Rows	8	12	16	24
Max GPA	20	12	9	5



Table Of Contents

Introduction

- Safety Information1
- Basic Steps to Install your Fertilizer System1
- Complete Fertilizer System Example Drawings2-3

A

Introduction

Components - Liquid

- Flowmeters, Section Valves4-5
- Pressure Sensor, Pump Priming and Air Bleed Valve6
- Flow Indicators and Manifolds, Check Valves, Orifice Charts7-14
- Dual Check Valve Systems, Row Distribution15-18

B

Components
Liquid

Components - Wiring & Electrical

- Connecting to John Deere Rate Controller19
- Schematics, System Layout, PWM EPD20-21
- Harness Drawings22-29

D

Components
Wiring & Elec.

Installation Overview

- Floating Ball Flow Indicators, Tower Mounting Options30-32
- Tower 110 Plumbing Overview and Valve Operation, Recirculation33
- Tower 200 Plumbing Overview and Valve Operation, Agitation34-35

E

Installation
Overview

Setup & Operation

- John Deere Rate Controller Setup36
- Implement Setup37
- System Setup, PWM Setup, Pressure Sensor Calibration38-39
- Set up Alarms and Rates40
- Initial Operation, Section Test41
- Nozzle Flow Check42
- Calibrate Flowmeter43

F

Setup &
Operation

Troubleshooting

- Pump Will Not Run44-45
- Application Rate Fluctuates, Slow Getting to Target Rate46
- Flowmeter Tap Test47
- Section Valve Won't Move, Pressure Sensor48
- Diagnostics-Readings Screens49
- Other Troubleshooting Issues50-51
- Charts to determine system flow requirements52-54

G

Trouble-
Shooting

Maintenance & Parts

- Winterization55
- **Pre-season Service**55

H

Maintenance
& Parts

©2010-2019 SureFire Ag Systems



396-001060

SureFire Tower for JD GRC-PWM Control

Revised 08/15/2019



Safety

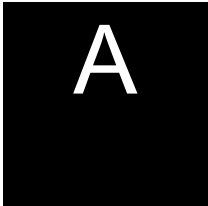

TAKE NOTE! THIS SAFETY ALERT SYMBOL FOUND THROUGHOUT THIS MANUAL IS USED TO CALL YOUR ATTENTION TO INSTRUCTIONS INVOLVING YOUR PERSONAL SAFETY AND THE SAFETY OF OTHERS. FAILURE TO FOLLOW THESE INSTRUCTIONS CAN RESULT IN INJURY OR DEATH.



**THIS SYMBOL MEANS
ATTENTION!**

BECOME ALERT!

YOUR SAFETY IS INVOLVED!

Note the use of the signal words DANGER, WARNING and CAUTION with the safety messages. The appropriate signal word for each has been selected using the following guidelines:



DANGER: Indicates an imminently hazardous situation that, if not avoided, will result in death or serious injury. This signal word is to be limited to the most extreme situations typically for machine components which, for functional purposes, cannot be guarded.



WARNING: Indicates a potentially hazardous situation that, if not avoided, could result in death or serious injury, and includes hazards that are exposed when guards are removed. It may also be used to alert against unsafe practices.



CAUTION: Indicates a potentially hazardous situation that, if not avoided, may result in minor or moderate injury. It may also be used to alert against unsafe practices.

NOTICE is used to address safety practices not related to personal safety.





Hydraulic Fluid and Equipment Safety

If your system uses hydraulic equipment with hydraulic fluid under extremely high pressure, please note:

Hydraulic fluid escaping under pressure can have sufficient force to penetrate the skin causing serious injury. Keep all hoses and connections in good serviceable condition. Failure to heed may result in serious personal injury or death. Avoid the hazard by relieving the pressure before disconnecting lines or performing work on the system.

Make sure hydraulic fluid connections are tight and all hydraulic hoses and lines are in good condition before applying pressure to the system. Use a piece of paper or cardboard, NOT BODY PARTS, to check for suspected leaks. Wear protective gloves and safety glasses or goggles when working with hydraulic systems. DO NOT DELAY!

Check hydraulic hoses and fittings frequently. Loose, broken, and missing hardware can cause equipment to not perform properly and can result in serious injury or death. Hydraulic systems can be hot and cause burns. Before working on any system, wait until the fluid has cooled.

If an accident occurs, see a doctor familiar with this type of injury immediately. Any fluid injected into the skin or eyes must be treated within a few hours or gangrene may result.



A Word to the Operator

It is YOUR responsibility to read and understand the safety messages in this manual. YOU are the key to safety.
SAFETY IS YOUR RESPONSIBILITY.

This system may apply many different kinds of agricultural liquid products. Read and follow all label information and instructions related to the handling, storage, and application of the product you are using.

All electrical harnessing should be checked regularly and should be routed and secured so it will not be pinched, cut, or stretched.

General Description

A

Introduction

You have purchased a SureFire fertilizer system for your equipment. This system will be controlled by your John Deere GS2 or GS3 display and John Deere GreenStar Rate Controller, which you will need to purchase from your John Deere dealer. The GS2 2600 and GS3 2630 function almost identically in regards to rate control. The Rate Controller will adjust the speed of the SureFire electric pumps based on feedback from the flowmeter and vehicle speed. The system is capable of using John Deere Section Control to minimize overlap areas with optional section valves.

Basic Installation Steps

1. Have John Deere GreenStar Rate Controller (GRC) mounted and wired by your John Deere Dealer to connect to your GS2 or GS3 display in the cab.
2. Open the packages and familiarize yourself with the components. See the System Overview Examples on the following pages to see the big picture of how SureFire Fertilizer Systems are installed. Refer to manual sections B & D for component information.
3. Mount the Tower or Accelerator Tank on your equipment. Electric pumps should be located close to the tanks. They will push the product a long distance, but are not as good at pulling product a long distance.
4. Plumb the tank to the Tower inlet. See section E for details.
5. Install the plumbing kit including section valves, flow indicator columns / manifolds, check valves, plumbing to each row unit delivery point. See section B for information on these components.
6. Attach the flowmeter outlet to section valve or manifold inlet. Attach section valve outlets to flow indicator inlets.
7. Attach harnesses as shown in Section D.
8. Set up Controller for SureFire fertilizer system as shown in Section F.
9. Fill system with water, conduct initial operation and tests per Section F.
10. Winterize system with RV Antifreeze if freezing temperatures are expected.
11. Do pre-season service each year as described on page 49.

System Overview - Example 1

A Introduction

The following gives an example of a complete SureFire Fertilizer system with these components:

- John Deere GS2 or GS3
- John Deere GreenStar Rate Controller (GRC)
- Tower 110
- Section Valves
- Flow Indicators
- Check Valves with Colored Disc Orifices

SureFire 37 Pin to 12-pin Product and 14-pin Section Adapter Harness- (connector detail in Section D)
(Older harnesses have twin 16-pin connectors)

14-pin Section Valve Harness (connector detail in Section D)

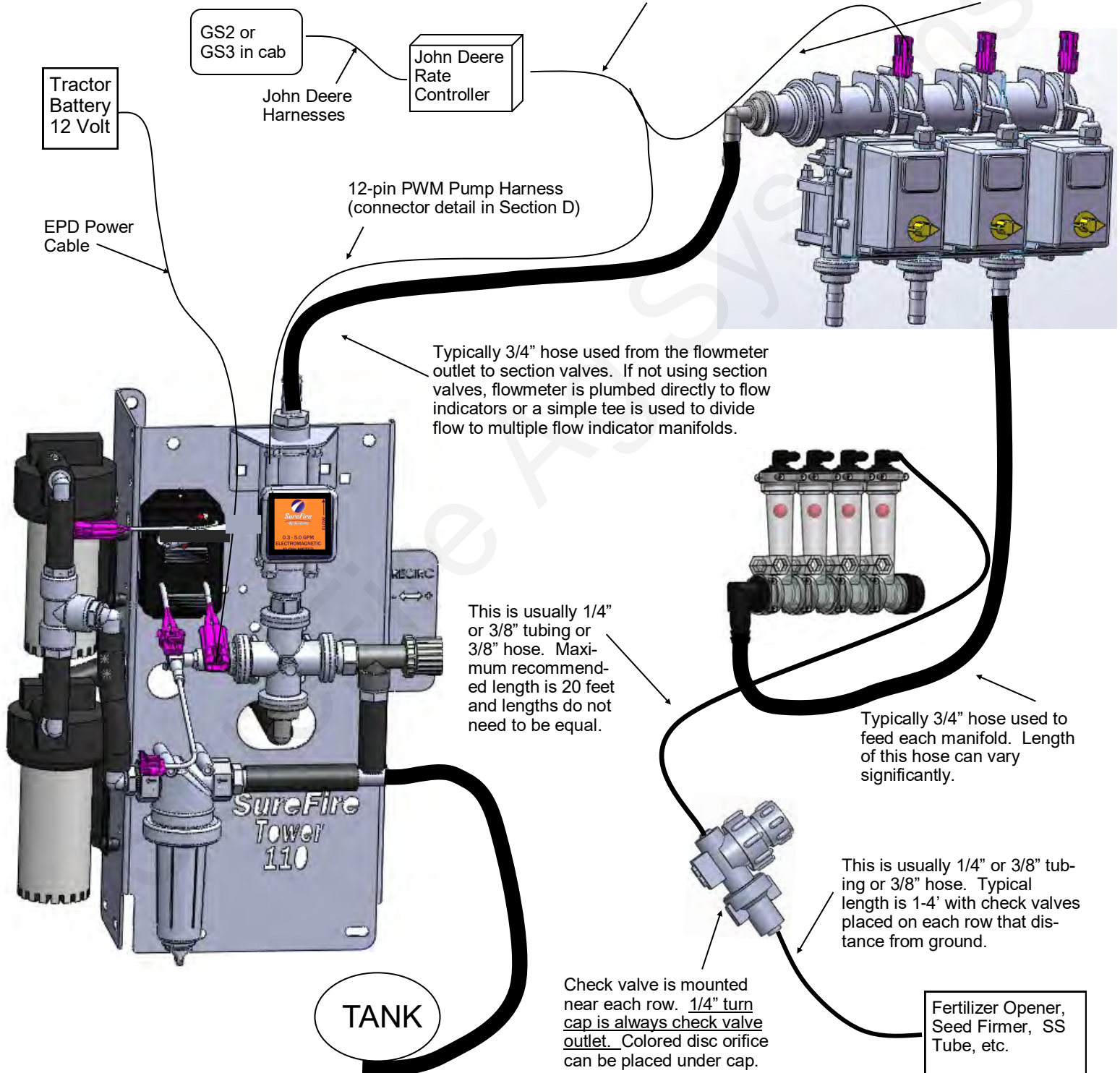

System Overview - Example 2

The following gives an example of a complete SureFire Fertilizer system with these components:

- John Deere GS2 or GS3
- John Deere GreenStar Rate Controller (GRC)
- Accelerator with Tower 200
- Dual Check Valve Distribution System
- Dual Metering Tube

SureFire 37 Pin to 12-pin Product and 14-pin Section Adapter Harness- (connector detail in Section D) (*Older harnesses have twin 16-pin connectors*)

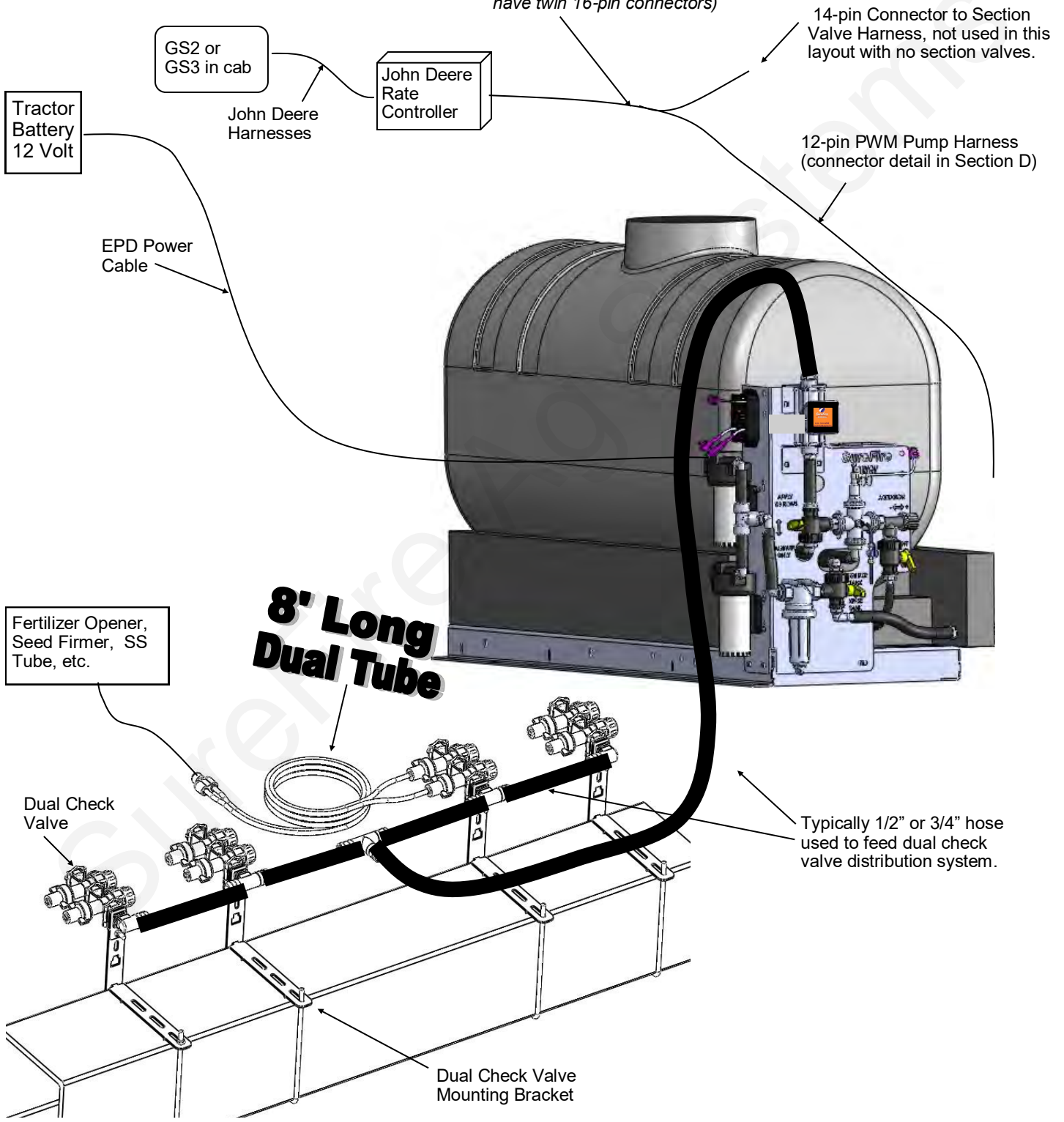

14-pin Connector to Section Valve Harness, not used in this layout with no section valves.

12-pin PWM Pump Harness (connector detail in Section D)

8' Long Dual Tube

Typically 1/2" or 3/4" hose used to feed dual check valve distribution system.

Fertilizer Opener, Seed Firmer, SS Tube, etc.

Dual Check Valve

Dual Check Valve Mounting Bracket

Electromagnetic Flowmeter Kits

0.13 - 2.6 GPM
 0.3 - 5.0 GPM
 0.08 - 1.6 GPM

Item Number 500-02-2040
 Item Number 500-02-2050

Flowmeter Only
 204-01-46211CUF00
 204-01-46211CUF01
 204-01-46211CUF05

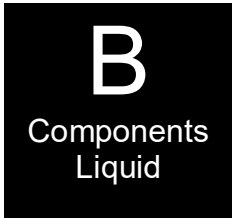

Before doing any arc welding on the implement, unplug the cable to the flowmeter, or damage to the flowmeter may result.

New Look in 2017—Black body with orange label. Same accurate, reliable electromagnetic technology. 3-pin Amp SuperSeal connector is sealed to flowmeter body for tighter, cleaner connection.

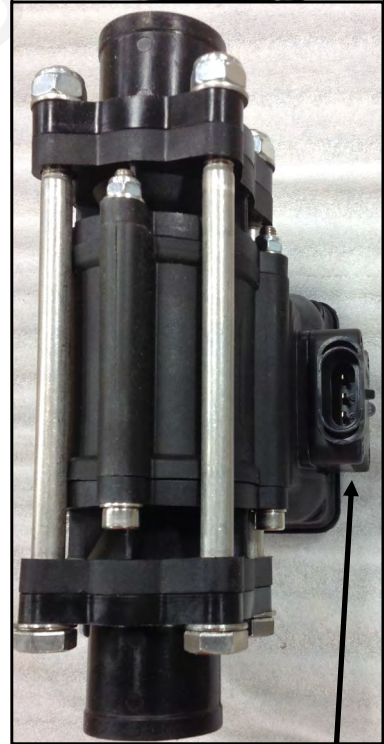

Amp SuperSeal 3-pin connector
 Use adapter 201-17842 to connect to 3-pin MP harness

Mounting Bracket, Used in Tower 110 & 200 (Tower 200 shown) 410-2106Y1

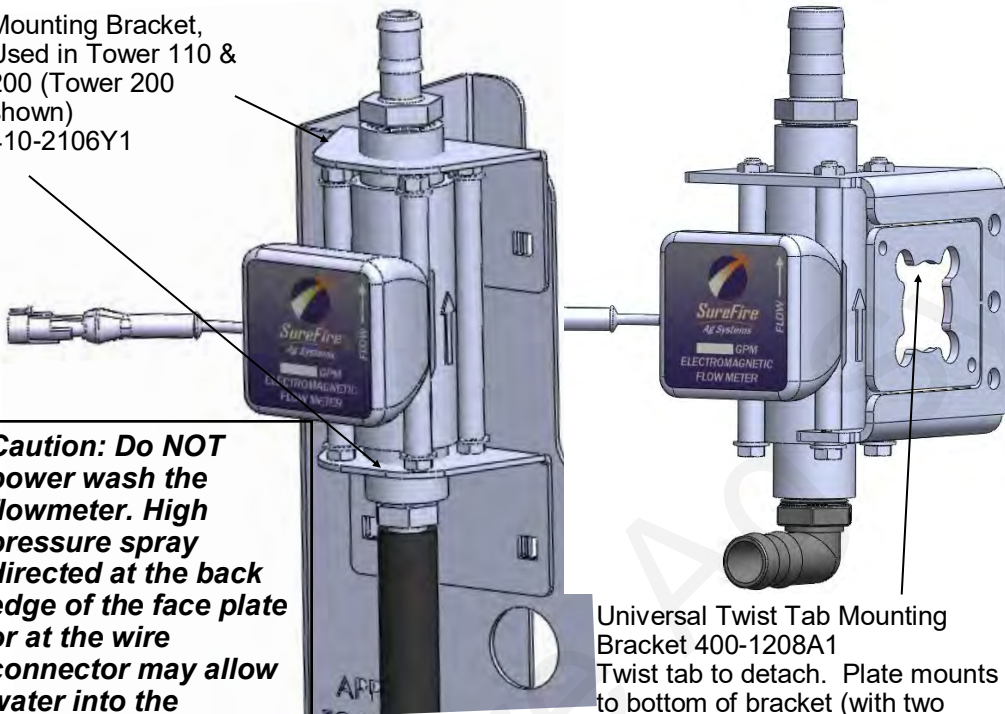

Universal Twist Tab Mounting Bracket 400-1208A1
 Twist tab to detach. Plate mounts to bottom of bracket (with two 1/4"x1" carriage bolts) to capture flowmeter.

Caution: Do NOT power wash the flowmeter. High pressure spray directed at the back edge of the face plate or at the wire connector may allow water into the flowmeter electronics.

Electromagnetic flowmeters are superior to traditional turbine flowmeters in two basic ways. First, they have no moving parts. This translates into no wear items or potential for contaminants to jam a spinning turbine.

Second, electromagnetic flowmeters detect the flow by electrically measuring the velocity of the liquid, which makes them independent of viscosity or density of the fluid measured. They are extremely accurate using the standard calibration number.

SureFire still recommends you perform a catch test to verify the system is properly installed and configured.

Flowmeter Model (orange label or blue label)	Pulses/Gal	FPT Size	Hose Barb In kit
0.13 - 2.6 GPM	3000	3/4"	3/4"
0.3 - 5.0 GPM	3000	3/4"	3/4"
0.08-1.6 GPM	22710	3/4"	3/4"



Serial number label on side also shows pulses per gallon.

Each flowmeter has a different diameter sensing element. Although the calibration numbers may be the same, the proper sized flowmeter must be used.

* Earlier model flowmeters (meters with white labels with black text) have different calibration numbers. See the documentation for those meters to find calibration numbers.)



Section Valves

B
Components
Liquid

105-100075BRB90

105-100PLG (alternate
105-100PLG025 includes 1/4" pipe
thread for gauge)

Note: Ensure back-side port
is capped prior to use

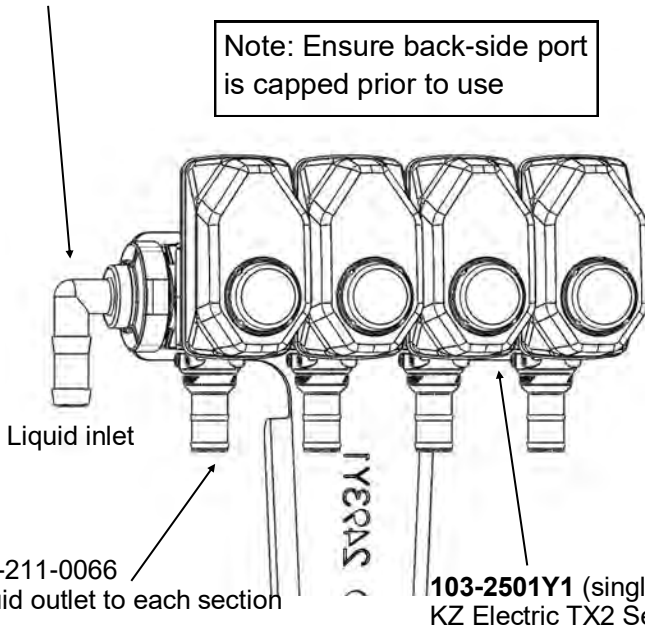

117-211-0066
Liquid outlet to each section

103-2501Y1 (single complete valve)
KZ Electric TX2 Series, 1 ball valve

Additional Parts:

- 1" Gasket 105-100G-H
- 1" Clamp 105-FC100

**Tower 110 Section Valve
Bracket**
Item Number 410-2110Y2

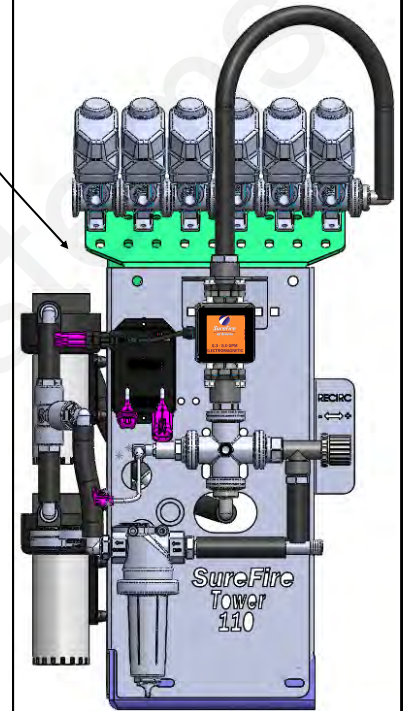

The Tower 110 can have up to 6 section valves mounted directly to the top of it with this bracket.

This is a 3-way valve. If product will not flow when valve is ON, either move the outlet hose to the other port, or remove actuator and rotate valve ball 180°, and replace actuator.



Green Light-
Valve ON

Red Light
Valve OFF—
connected to
Power

Replacement Valve Actuator—
104-KZ1169—KZ Electric TX2
Series Actuator

If valve indicator stays GREEN all the time or if valve indicator is not in full ON or full OFF position, replace actuator. Pull gray pin to remove actuator from valve.

How it Works

Section valves can be assembled into groups with a common inlet to control flow to each section. Common assemblies use up to 5-6 valves, however, more can be used where practical. Many alternate fittings can be used to accommodate different hose sizes and configurations.

The valves have a 3-pin weather pack electrical connector. This has a power, ground, and switched signal wire. The power measured to ground should have 12 volts when the controller is on. The switched signal wire will have 12 volts to turn the valve on, and 0 volts to turn the valve off.

Wiring Connector:

- Pin A—Red, 12 Volts +
- Pin B—Black, Ground -
- Pin C—White, Signal
- 12V=on ; 0V=off

Mounting Hardware:

- 2 Valve Bolt Kit 384-1100
- Mounting Bracket 400-2493Y1

Pressure Sensor

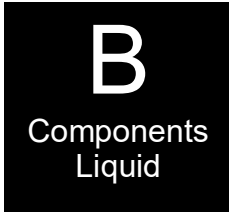

The Tower 110 and 200 come equipped with a 100 psi (0 to 5 volt) pressure sensor to work with the John Deere controller. This sensor is a 3 wire type sensor. It has a 1/4" MPT fitting.

The John Deere Rate Controller is able to accommodate 2 pressure sensors, both of which can be displayed on the GS3 display. (When using adapter harness 213-00-3765Y1, if the sensor is plugged into the Section harness, it must be set up as Sensor 2.)

The display will show the system pressure on the screen. **The pressure reading is only for informational purposes and is NOT used in the flow control process, but it is very helpful to understanding system performance and in troubleshooting.** Flow control uses the flowmeter feedback only.

Go to *Diagnostics > Readings > Sensors/Status* for feedback on pressure sensor. Calibration Points should be close to 0 PSI = 0.0 v; 90 PSI = 4.5 v. If there is no voltage showing here when system is running, try setting up sensor as Sensor 2. If still no voltage, check harnessing by using a AA or AAA battery and connecting Pin A of the Pressure connector to the (+) end of the battery, and Pin C to the (-) end of the battery. It should show 1.5 v and 30 PSI on the screen.

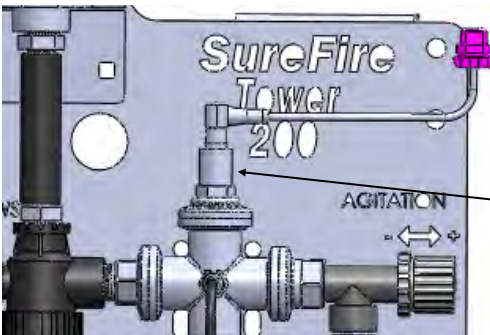

Pressure Sensor (3-wire type) with harness 521-05-050150

GS2 / GS3 Pressure Calibration:
50 mv/psi
Unplug the sensor when entering the Calibration number.

Pump Priming and Air Bleed Valve

An air bleed valve is included with each pump to aid in system priming. It is shipped in the pump accessories bag and *must be installed during system installation.*

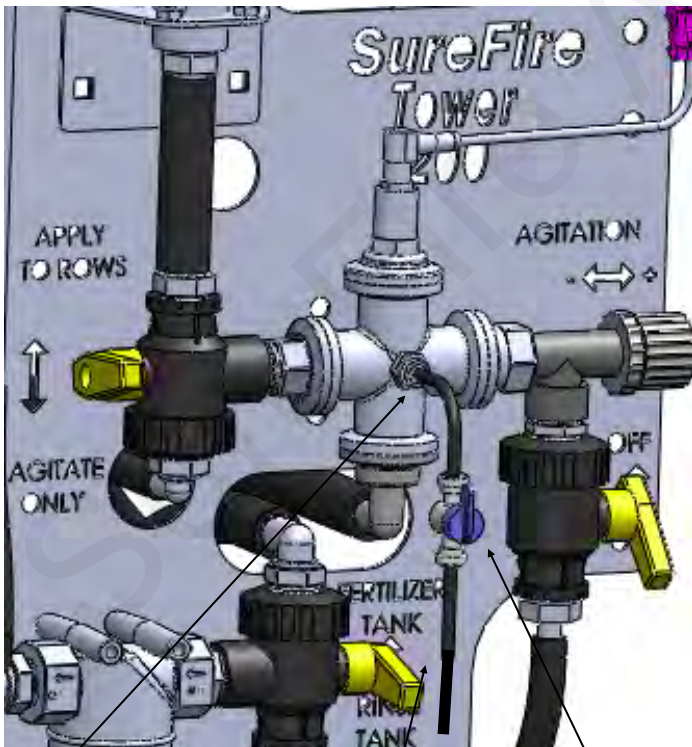

Shipped from factory with plug installed.

1/4" Tubing

1/4" air bleed valve

Why use an air bleed valve:

Most fertilizer systems are equipped with a 4 lb. or 10 lb. check valve on the end of each hose delivering fertilizer to the ground. These valves do not let air escape from the system, unless it is pressurized. 12 volt liquid pumps are not good air compressors. Therefore, the pump can struggle to prime due to air trapped on the outlet side of the pump.

The air bleed valve is a small 1/4" valve that when opened lets air escape from the pump outlet at zero pressure. **To prime the pump, open until liquid comes out and then close the valve.**

How to install the air bleed valve:

Remove the 1/4" plug from the quick connect fitting on the center cross on the Tower (see picture). Next, insert the 1/4" tubing in the quick connect fitting. Run the 1/4" tubing to an easily accessible spot on your equipment. Next, cut the tubing and push the 1/4" valve onto the tubing. Finally, run the tubing to a low location where any fertilizer that escapes will run on the ground.

Be sure the air bleed valve tube does not become plugged with dirt or it will not allow the air to bleed.

Product Distribution

To assure proper and even distribution to each row, the product being applied must be metered to each individual row. This metering is done by one of the 3 following methods which create back pressure so an equal amount of liquid is applied to each row.

1. A metering orifice may be placed in the top cap of each floating ball flow indicator. (See photos on page 9—this is not used very often.)
2. A metering orifice may be placed in the check valve cap in the line that leads to each row. (See photo on page 11)
3. A dual metering tube kit with dual check valves may be used. (See pages 15-18)

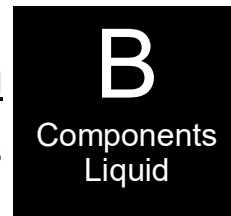

Floating Ball Flow Indicator & Manifold System

Flow indicators give a clear visual signal that a fertilizer system is working. These indicators use an o-ring and wire clip connection to snap together in any configuration necessary.

SureFire has simple tee brackets and U-bolts that will mount these to a variety of bar sizes.

Two main types of flow indicators are used. On 30" row spacing, the low flow column with 1/4" or 3/8" push to connect outlet is recommended for rates under 10 GPA. For rates over 10 GPA the full flow column with 3/8" hose barb outlet is preferred.

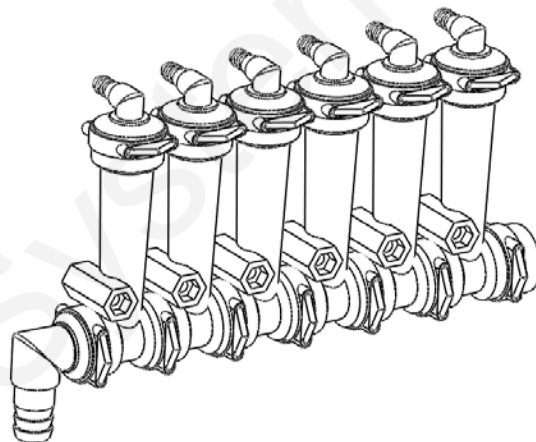

Parts List

Complete Columns

- 701-20460-950 Single Full Flow Column with 3/8" HB - 90 Degree Outlet
- 701-20460-940 Single Full Flow Column with 3/8" QC - 90 Degree Outlet
- 701-20460-960 Single Full Flow Column with 1/2" HB - 90 Degree Outlet
- 701-20460-935 Single Low Flow Column with 3/8" QC - 90 Degree Outlet
- 701-20460-920 Single Low Flow Column with 1/4" QC - 90 Degree Outlet

Fittings

- 701-20503-00 ORS x 3/4" HB - Straight
- 701-20511-00 ORS x 3/8" HB - 90 Degree
- 701-20512-00 ORS x 1/2" HB - 90 Degree
- 701-20513-00 ORS x 3/4" HB - 90 Degree
- 701-20516-00 ORS x 1/4" QC - 90 Degree
- 701-20517-00 ORS x 3/8" QC - 90 Degree
- 701-20518-00 ORS x 1/4" FPT - 90 Degree
- 701-20519-00 ORS x 1/4" FPT - Straight
- 701-20520-00 ORS Male x ORS Female - 90 degree
- 701-20521-00 Wilger End Cap
- 701-20523-00 ORS Male x ORS Female x 3/8" FPT - Isolator
- 701-20525-00 ORS Male x ORS Male x 1" FPT - Tee

Service Parts Only

- 701-20460-02 Wilger Flow Indicator Ball Retainer
- 701-20460-03 FKM O-Ring for indicator body & fittings
- 701-20460-04 Wilger Lock U-clip
- 701-20460-05 Flow Indicator Ball - 1/2" SS Ball
- 701-20460-06 Flow Indicator Ball - Maroon Glass
- 701-20460-07 Flow Indicator Ball - Red Celcon
- 701-20460-08 Flow Indicator Ball - Green Poly
- 701-20460-09 Flow Indicator Ball - Black Poly
- 701-20460-15 Viton O-Ring for column & fittings
- 701-40225-05 Viton O-Ring for Orifice

Brackets & U-Bolts

- 400-1037A1 3-6 Row Bracket
- 400-3155Y1 7-12 Row Bracket
- 400-2011A1 White Backer Plate for 3-6 Row Bracket
- 400-2010A1 White Backer Plate for 7-12 Row Bracket
- 400-1315A2 Flow Indicator Bracket, 6-8 in wide hitch mount



Floating Ball Flow Indicators- Full Flow Column (mostly 3/8" HB)

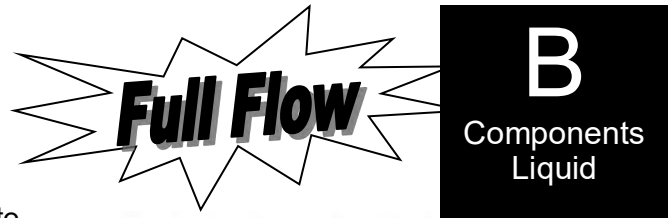

The full flow column is typically used with rates over 10 GPA on 30" rows. For rates less than 10 GPA SureFire recommends the low flow columns with 1/4" or 3/8" push to connect (QC) outlet fittings.

The full flow columns are most often assembled with 3/8" hose barb outlets. See the low flow info below for the difference between full and low flow columns.

Full Flow Indicators w/ 3/8" Hose Barb Outlet

Column Flow (GPM):	.05-2.70 GPM
Equivalent Application Rate On 30" Rows at 6 MPH:	2-70 GPA

Ball Selection for 30" Rows

GPM	GPA	Ball
.05-.18	2-6	Green Plastic*
.09-.30	3-10	Red Plastic*
.31-.72	10-20	Maroon Glass
.40-2.1	13-70	Stainless Steel (1/2")

*Plastic balls may float on heavier fertilizers, such as 10-34-0. SureFire recommends using the low flow column for these flow rates.

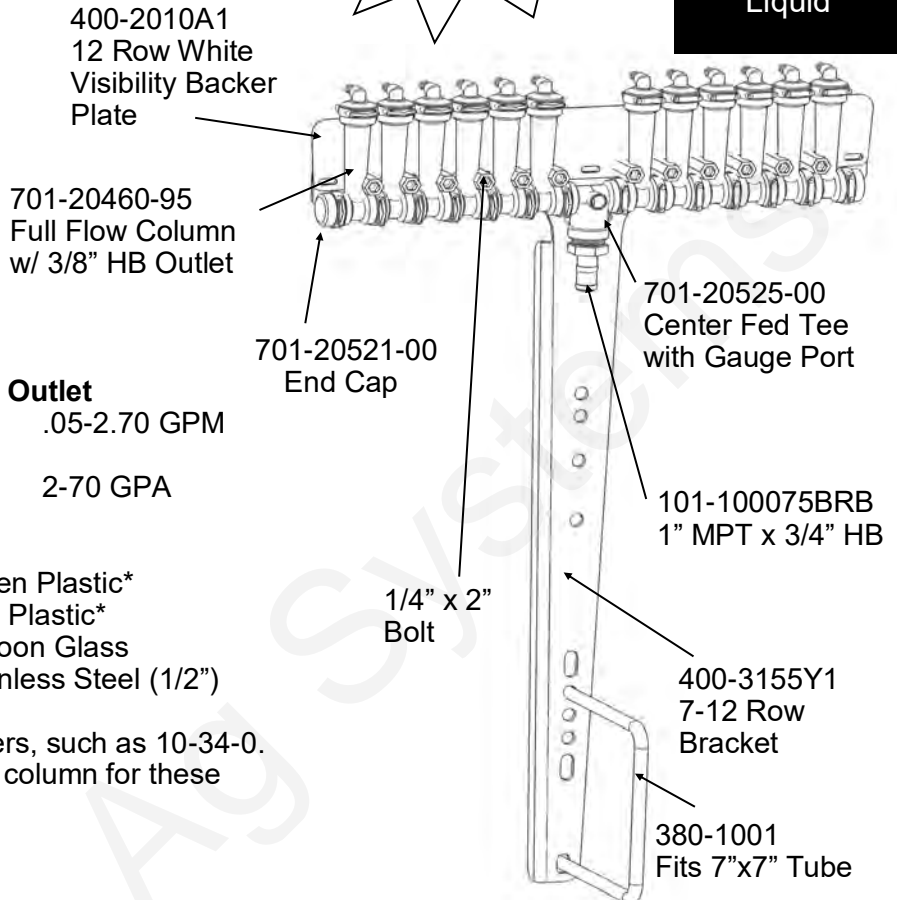

Low Flow Column (mostly 1/4" QC or 3/8" QC)

The low flow column has a smaller internal diameter. This means a heavier ball can be used to monitor a smaller flow.

SureFire uses the low flow columns with 1/4" push to connect outlet fittings. The flow capability of 1/4" tubing and the low flow column are a great pair for rates on 30" rows under 10 GPA.

Externally, the low flow column can only be identified by "Low Flow" molded into one side of the column. All the same fittings work with low flow and full flow columns.

Low Flow Indicators w/ 1/4" Push to Connect (QC) Outlet

Column Flow (GPM):	.03-.30 GPM
*** Low Flow Column with 3/8" hose barb	.03 - .70 GPM
Equivalent Application Rate On 30" Rows at 6 MPH (1/4" QC):	1-10 GPA

Ball Selection for 30" Rows

GPM	GPA	Ball
.03-.09	1-3	Green Plastic*
.05-.14	2-4	Red Plastic*
.10-.18	3-6	Maroon Glass
.15-.70	5-10	Stainless Steel (1/2")

*These balls may float on heavier fertilizers, such as 10-34-0. Use Maroon Glass in this case.

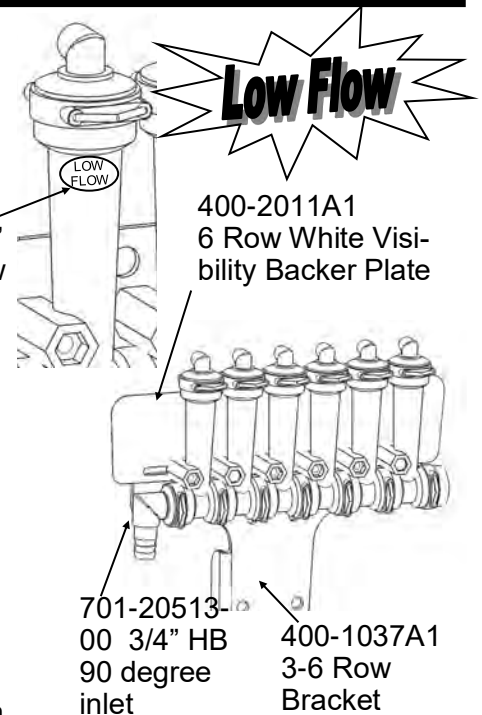

Floating Ball Flow Indicators— Metering Orifice Selection for 30” Rows

See www.surefireag.com for other row spacings
(This system is not used very often)

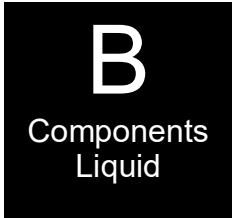

30” Spacing

Orifice	PSI	Gal/Min 28-0-0	MPH						
			4.0	4.5	5.0	5.5	6.0	6.5	7.0
28	10	0.043	2.15	1.91	1.72	1.56	1.43	1.32	1.23
	20	0.061	3.02	2.69	2.42	2.20	2.02	1.86	1.73
	30	0.075	3.72	3.31	2.98	2.71	2.48	2.29	2.13
	40	0.087	4.29	3.82	3.43	3.12	2.86	2.64	2.45
	50	0.097	4.82	4.28	3.85	3.50	3.21	2.97	2.75
	60	0.106	5.26	4.67	4.21	3.82	3.50	3.23	3.00
35	10	0.070	3.46	3.08	2.77	2.52	2.31	2.13	1.98
	20	0.098	4.86	4.32	3.89	3.54	3.24	2.99	2.78
	30	0.120	5.96	5.30	4.77	4.33	3.97	3.67	3.40
	40	0.139	6.88	6.11	5.50	5.00	4.58	4.23	3.93
	50	0.156	7.71	6.85	6.17	5.61	5.14	4.74	4.41
	60	0.170	8.41	7.48	6.73	6.12	5.61	5.18	4.81
40	10	0.090	4.47	3.97	3.57	3.25	2.98	2.75	2.55
	20	0.127	6.31	5.61	5.05	4.59	4.21	3.88	3.60
	30	0.157	7.75	6.89	6.20	5.64	5.17	4.77	4.43
	40	0.181	8.94	7.94	7.15	6.50	5.96	5.50	5.11
	50	0.202	9.99	8.88	7.99	7.26	6.66	6.15	5.71
	60	0.221	10.95	9.73	8.76	7.96	7.30	6.74	6.26
46	10	0.119	5.91	5.26	4.73	4.30	3.94	3.64	3.38
	20	0.169	8.37	7.44	6.69	6.08	5.58	5.15	4.78
	30	0.207	10.25	9.11	8.20	7.45	6.83	6.31	5.86
	40	0.239	11.83	10.51	9.46	8.60	7.88	7.28	6.76
	50	0.267	13.23	11.76	10.58	9.62	8.82	8.14	7.56
	60	0.293	14.50	12.89	11.60	10.55	9.67	8.92	8.29
52	10	0.149	7.36	6.54	5.89	5.35	4.91	4.53	4.21
	20	0.210	10.38	9.23	8.31	7.55	6.92	6.39	5.93
	30	0.257	12.70	11.29	10.16	9.24	8.47	7.82	7.26
	40	0.296	14.67	13.04	11.74	10.67	9.78	9.03	8.39
	50	0.332	16.43	14.60	13.14	11.95	10.95	10.11	9.39
	60	0.363	17.96	15.96	14.37	13.06	11.97	11.05	10.26
63	10	0.218	10.78	9.58	8.62	7.84	7.18	6.63	6.16
	20	0.307	15.20	13.51	12.16	11.05	10.13	9.35	8.69
	30	0.376	18.62	16.55	14.89	13.54	12.41	11.46	10.64
	40	0.435	21.51	19.12	17.21	15.64	14.34	13.24	12.29
	50	0.486	24.05	21.38	19.24	17.49	16.03	14.80	13.74
	60	0.532	26.33	23.40	21.06	19.15	17.55	16.20	15.04
78	10	0.341	16.87	14.99	13.49	12.27	11.24	10.38	9.64
	20	0.481	23.83	21.18	19.06	17.33	15.89	14.66	13.62
	30	0.590	29.22	25.97	23.37	21.25	19.48	17.98	16.70
	40	0.681	33.73	29.98	26.98	24.53	22.49	20.76	19.27
	50	0.762	37.72	33.53	30.17	27.43	25.14	23.21	21.55
	60	0.835	41.31	36.72	33.05	30.04	27.54	25.42	23.60
98	10	0.553	27.38	24.34	21.90	19.91	18.25	16.85	15.64
	20	0.782	38.72	34.42	30.98	28.16	25.82	23.83	22.13
	30	0.956	47.31	42.05	37.85	34.41	31.54	29.11	27.03
	40	1.106	54.76	48.67	43.81	39.82	36.50	33.70	31.29
	50	1.239	61.33	54.51	49.06	44.60	40.88	37.74	35.04
	60	1.354	67.02	59.58	53.62	48.74	44.68	41.24	38.30
107	10	0.649	32.11	28.54	25.69	23.35	21.41	19.76	18.35
	20	0.920	45.56	40.50	36.45	33.13	30.37	28.04	26.03
	30	1.124	55.63	49.45	44.51	40.46	37.09	34.24	31.79
	40	1.301	64.39	57.24	51.52	46.83	42.93	39.63	36.80
	50	1.451	71.84	63.86	57.47	52.25	47.89	44.21	41.05
	60	1.584	78.41	69.70	62.73	57.03	52.27	48.25	44.81
130	10	0.938	46.43	41.27	37.15	33.77	30.96	28.57	26.53
	20	1.319	65.27	58.02	52.22	47.47	43.51	40.17	37.30
	30	1.619	80.16	71.26	64.13	58.30	53.44	49.33	45.81
	40	1.867	92.43	82.16	73.94	67.22	61.62	56.88	52.82
	50	2.088	103.38	91.89	82.70	75.19	68.92	63.62	59.07
	60	2.292	113.46	100.85	90.76	82.51	75.64	69.82	64.83

Tower Electric Pump Pressure Recommendations (with 4 lb check valves):

- Minimum 10 PSI
- Maximum 30 PSI (pump can do 50 PSI or more if total output is not too great)

PumpRight Hydraulic Pressure Recommendations (with 10 lb check valves):

- Minimum 20 PSI
- Maximum 80 PSI

Chart is for 28-0-0 Fertilizer @ 70°

- Heavier fertilizers (like 10-34-0) will have 5-15% less flow than chart indicates for a certain pressure
- Cold fertilizers will cause system pressure to increase at a given application rate.
- Tower Electric Pump Systems will have reduced flow and increased electrical current draw due to cold fertilizer increasing operating pressure. **Use the largest orifice possible for cold weather operation.**

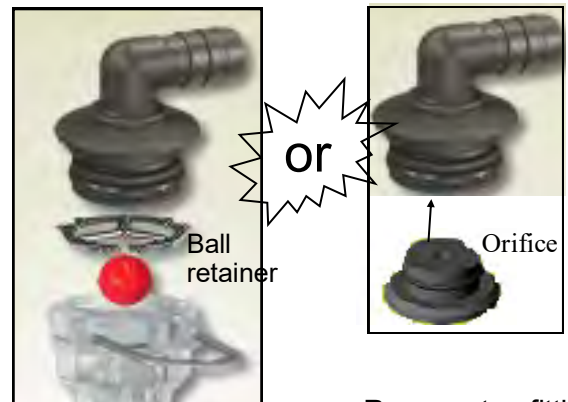

If using a metering orifice in the flow indicator, the orifice replaces the ball retainer. If not using an orifice here, the ball retainer must be in place.

Remove top fitting of each column. Then push metering orifice into bottom of each outlet fitting. (This is not used very often.)

All application rates (gallons/acres) are estimates based on 0-28-0 (10.65 lbs/gallon) at 70 degrees F.

Check Valves

B
Components
Liquid

4 lb check valve with 1/4" quick connect fittings

4 lb check valves are typically used with **electric pump systems**. SureFire recommends this valve for use with 1/4" tubing applying up to 10 GPA on 30" rows. The recommended minimum system operating pressure for this check is 10 psi, to ensure all checks open fully.

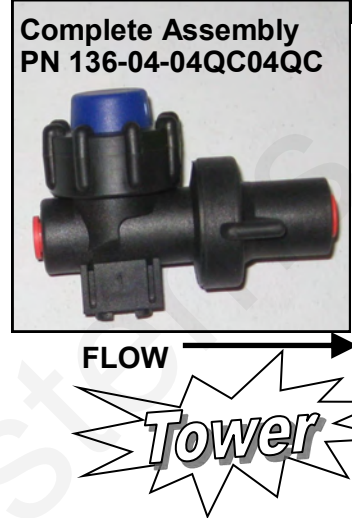
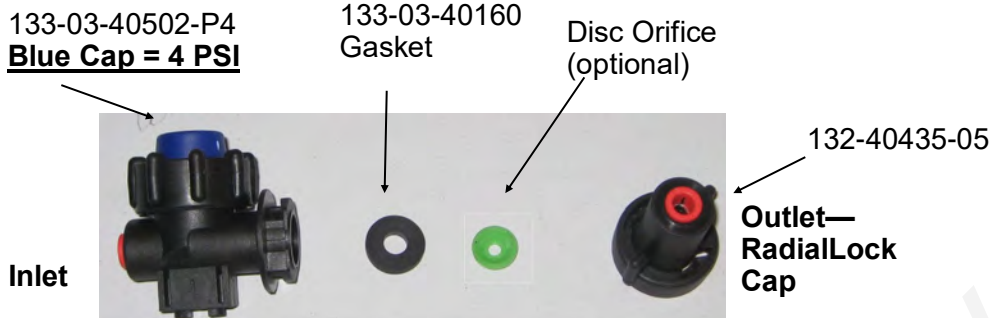

10 lb check valve with 3/8" hose barbs

The recommended check valve for most **PumpRight** installations is the 10 lb check with 3/8" hose barbs. This works with 3/8" rubber hose which SureFire recommends for most applications over 10 GPA on 30" rows. The recommended minimum system operating pressure for this check is 20 psi, to ensure all checks open fully.

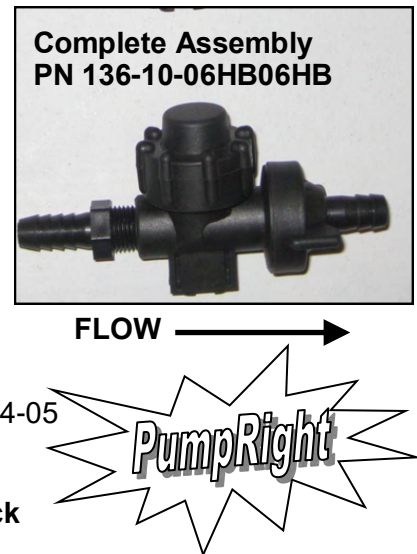
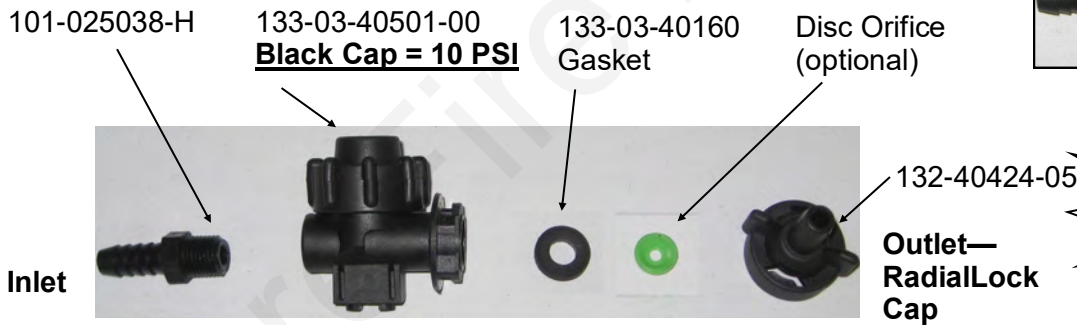

Special Purpose Check Valve Assemblies

Assembly Part Number	Description	Suggested Uses (30" rows)
136-10-04QC04QC	1/4" QC x 1/4" QC 10 lb	< 10 GPA with PumpRight & 1/4" Tubing
136-10-06QC06QC	3/8" QC x 3/8" QC 10 lb	With 3/8" tubing plumbing
136-04-06HB06HB	3/8" HB x 3/8" HB 4 lb	> 10 GPA with Electric Pumps
136-04-08HB08HB	1/2" HB x 1/2" HB 4 lb	> 50 GPA with PumpRight
136-10-08HB08HB	1/2" HB x 1/2" HB 10 lb	> 50 GPA with PumpRight

Colored Disc Orifice Chart for 30" rows

B

Components
Liquid

30" Spacing

Orifice Color (Approx Size)	PSI	Gal/Min 28-0-0	MPH						
			4.0	4.5	5.0	5.5	6.0	6.5	7.0
Pink (24)	10	0.033	1.62	1.44	1.30	1.18	1.08	1.00	0.93
	20	0.046	2.28	2.02	1.82	1.66	1.52	1.40	1.30
	30	0.057	2.80	2.49	2.24	2.04	1.87	1.73	1.60
	40	0.065	3.24	2.88	2.59	2.36	2.16	1.99	1.85
	50	0.073	3.64	3.23	2.91	2.64	2.42	2.24	2.08
	60	0.081	3.99	3.54	3.19	2.90	2.66	2.45	2.28
Gray (30)	10	0.050	2.50	2.22	2.00	1.82	1.66	1.54	1.43
	20	0.072	3.55	3.15	2.84	2.58	2.37	2.18	2.03
	30	0.088	4.34	3.85	3.47	3.15	2.89	2.67	2.48
	40	0.101	4.99	4.44	4.00	3.63	3.33	3.07	2.85
	50	0.112	5.56	4.95	4.45	4.05	3.71	3.42	3.18
	60	0.124	6.13	5.45	4.91	4.46	4.09	3.77	3.50
Black (35)	10	0.070	3.46	3.08	2.77	2.52	2.31	2.13	1.98
	20	0.098	4.86	4.32	3.89	3.54	3.24	2.99	2.78
	30	0.120	5.96	5.30	4.77	4.33	3.97	3.67	3.40
	40	0.139	6.88	6.11	5.50	5.00	4.58	4.23	3.93
	50	0.156	7.71	6.85	6.17	5.61	5.14	4.74	4.41
	60	0.170	8.41	7.48	6.73	6.12	5.61	5.18	4.81
Brown (41)	10	0.094	4.64	4.13	3.71	3.38	3.10	2.86	2.65
	20	0.132	6.53	5.80	5.22	4.75	4.35	4.02	3.73
	30	0.162	8.02	7.13	6.41	5.83	5.34	4.93	4.58
	40	0.187	9.24	8.22	7.39	6.72	6.16	5.69	5.28
	50	0.209	10.34	9.19	8.27	7.52	6.89	6.36	5.91
	60	0.228	11.30	10.05	9.04	8.22	7.53	6.95	6.46
Orange (46)	10	0.119	5.91	5.26	4.73	4.30	3.94	3.64	3.38
	20	0.169	8.37	7.44	6.69	6.08	5.58	5.15	4.78
	30	0.207	10.25	9.11	8.20	7.45	6.83	6.31	5.86
	40	0.239	11.83	10.51	9.46	8.60	7.88	7.28	6.76
	50	0.267	13.23	11.76	10.58	9.62	8.82	8.14	7.56
	60	0.293	14.50	12.89	11.60	10.55	9.67	8.92	8.29
Maroon (52)	10	0.149	7.36	6.54	5.89	5.35	4.91	4.53	4.21
	20	0.210	10.38	9.23	8.31	7.55	6.92	6.39	5.93
	30	0.257	12.70	11.29	10.16	9.24	8.47	7.82	7.26
	40	0.296	14.67	13.04	11.74	10.67	9.78	9.03	8.39
	50	0.332	16.43	14.60	13.14	11.95	10.95	10.11	9.39
	60	0.363	17.96	15.96	14.37	13.06	11.97	11.05	10.26
Red (63)	10	0.218	10.78	9.58	8.62	7.84	7.18	6.63	6.16
	20	0.307	15.20	13.51	12.16	11.05	10.13	9.35	8.69
	30	0.376	18.62	16.55	14.89	13.54	12.41	11.46	10.64
	40	0.435	21.51	19.12	17.21	15.64	14.34	13.24	12.29
	50	0.486	24.05	21.38	19.24	17.49	16.03	14.80	13.74
	60	0.532	26.33	23.40	21.06	19.15	17.55	16.20	15.04
Blue (80)	10	0.351	17.39	15.46	13.91	12.65	11.59	10.70	9.94
	20	0.496	24.57	21.84	19.66	17.87	16.38	15.12	14.04
	30	0.608	30.09	26.75	24.08	21.89	20.06	18.52	17.20
	40	0.702	34.74	30.88	27.79	25.26	23.16	21.38	19.85
	50	0.785	38.86	34.54	31.08	28.26	25.90	23.91	22.20
	60	0.859	42.53	37.81	34.03	30.93	28.36	26.18	24.31
Yellow (95)	10	0.506	25.06	22.27	20.05	18.22	16.70	15.42	14.32
	20	0.715	35.39	31.46	28.32	25.74	23.60	21.78	20.23
	30	0.876	43.37	38.55	34.69	31.54	28.91	26.69	24.78
	40	1.009	49.94	44.39	39.95	36.32	33.29	30.73	28.54
	50	1.133	56.07	49.84	44.86	40.78	37.38	34.51	32.04
	60	1.239	61.33	54.51	49.06	44.60	40.88	37.74	35.04
Green (110)	10	0.686	33.95	30.18	27.16	24.69	22.63	20.89	19.40
	20	0.973	48.19	42.83	38.55	35.04	32.12	29.65	27.53
	30	1.186	58.70	52.18	46.96	42.69	39.13	36.12	33.54
	40	1.372	67.90	60.35	54.32	49.38	45.27	41.78	38.80
	50	1.531	75.78	67.36	60.63	55.12	50.52	46.64	43.30
	60	1.681	83.23	73.98	66.58	60.53	55.49	51.22	47.56

Tower Electric Pump Pressure Recommendations (with 4 lb check valves):

- Minimum 10 PSI
- Maximum 30 PSI (pump can do 50 PSI or more if total output is not too great)

PumpRight Pressure Recommendations (with 10 lb check valves):

- Minimum 20 PSI
- Maximum 80 PSI

Chart is for 28-0-0 Fertilizer @ 70°

- Heavier fertilizers (like 10-34-0) will have 5-15% less flow than chart indicates for a certain pressure
- Cold fertilizers will cause system pressure to increase at a given application rate.
- Tower Electric Pump Systems will have reduced flow and increased electrical current draw due to cold fertilizer increasing operating pressure. **Use the largest orifice possible for cold weather operation. This is absolutely essential for 24-row systems using electric pumps.**

Colored Disc Orifice assemblies under the check valve cap in most cases. (Drop the orifice with the hole down into the cap, then put the gasket on top of it.) The orifice can also be installed in a manifold (common on grain drills).

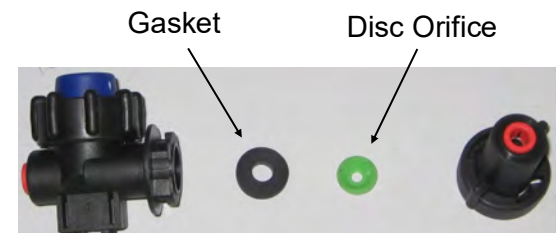

FLOW → 1/4 Turn Cap is Outlet

Colored Disc Orifice Chart Common Grain Drill Row Spacings

B

Components
Liquid

7.5" Spacing

Orifice Color (Approx Size)	PSI	Gal/Min 28-0-0	MPH						
			4.0	4.5	5.0	5.5	6.0	6.5	7.0
Pink (24)	10	0.033	6.5	5.8	5.2	4.7	4.3	4.0	3.7
	20	0.046	9.1	8.1	7.3	6.6	6.1	5.6	5.2
	30	0.057	11.2	10.0	9.0	8.2	7.5	6.9	6.4
	40	0.065	13.0	11.5	10.4	9.4	8.6	8.0	7.4
	50	0.073	14.5	12.9	11.6	10.6	9.7	8.9	8.3
60	0.081	15.9	14.2	12.8	11.6	10.6	9.8	9.1	
Gray (30)	10	0.050	10.0	8.9	8.0	7.3	6.7	6.1	5.7
	20	0.072	14.2	12.6	11.4	10.3	9.5	8.7	8.1
	30	0.088	17.3	15.4	13.9	12.6	11.6	10.7	9.9
	40	0.101	20.0	17.8	16.0	14.5	13.3	12.3	11.4
	50	0.112	22.3	19.8	17.8	16.2	14.8	13.7	12.7
60	0.124	24.5	21.8	19.6	17.8	16.4	15.1	14.0	
Black (35)	10	0.070	13.8	12.3	11.1	10.1	9.2	8.5	7.9
	20	0.098	19.4	17.3	15.6	14.1	13.0	12.0	11.1
	30	0.120	23.8	21.2	19.1	17.3	15.9	14.7	13.6
	40	0.139	27.5	24.5	22.0	20.0	18.3	16.9	15.7
	50	0.156	30.8	27.4	24.7	22.4	20.6	19.0	17.6
60	0.170	33.6	29.9	26.9	24.5	22.4	20.7	19.2	
Brown (41)	10	0.094	19	17	15	14	12	11	11
	20	0.132	26	23	21	19	17	16	15
	30	0.162	32	29	26	23	21	20	18
	40	0.187	37	33	30	27	25	23	21
	50	0.209	41	37	33	30	28	25	24
60	0.228	45	40	36	33	30	28	26	
Orange (46)	10	0.119	24	21	19	17	16	15	14
	20	0.169	33	30	27	24	22	21	19
	30	0.207	41	36	33	30	27	25	23
	40	0.239	47	42	38	34	32	29	27
	50	0.267	53	47	42	38	35	33	30
60	0.293	58	52	46	42	39	36	33	
Maroon (52)	10	0.149	29	26	24	21	20	18	17
	20	0.210	42	37	33	30	28	26	24
	30	0.257	51	45	41	37	34	31	29
	40	0.296	59	52	47	43	39	36	34
	50	0.332	66	58	53	48	44	40	38
60	0.363	72	64	57	52	48	44	41	
Red (63)	10	0.218	43	38	34	31	29	27	25
	20	0.307	61	54	49	44	41	37	35
	30	0.376	74	66	60	54	50	46	43
	40	0.435	86	76	69	63	57	53	49
	50	0.486	96	86	77	70	64	59	55
60	0.532	105	94	84	77	70	65	60	
Blue (80)	10	0.351	70	62	56	51	46	43	40
	20	0.496	98	87	79	71	66	60	56
	30	0.608	120	107	96	88	80	74	69
	40	0.702	139	124	111	101	93	86	79
	50	0.785	155	138	124	113	104	96	89
60	0.859	170	151	136	124	113	105	97	
Yellow (95)	10	0.506	100	89	80	73	67	62	57
	20	0.715	142	126	113	103	94	87	81
	30	0.876	173	154	139	126	116	107	99
	40	1.009	200	178	160	145	133	123	114
	50	1.133	224	199	179	163	150	138	128
60	1.239	245	218	196	178	164	151	140	

10" Spacing

Orifice Color (Approx Size)	PSI	Gal/Min 28-0-0	MPH						
			4.0	4.5	5.0	5.5	6.0	6.5	7.0
Pink (24)	10	0.033	4.9	4.3	3.9	3.5	3.2	3.0	2.8
	20	0.046	6.8	6.1	5.5	5.0	4.6	4.2	3.9
	30	0.057	8.4	7.5	6.7	6.1	5.6	5.2	4.8
	40	0.065	9.7	8.6	7.8	7.1	6.5	6.0	5.6
	50	0.073	10.9	9.7	8.7	7.9	7.3	6.7	6.2
60	0.081	12.0	10.6	9.6	8.7	8.0	7.4	6.8	
Gray (30)	10	0.050	7.5	6.7	6.0	5.4	5.0	4.6	4.3
	20	0.072	10.6	9.5	8.5	7.7	7.1	6.6	6.1
	30	0.088	13.0	11.6	10.4	9.5	8.7	8.0	7.4
	40	0.101	15.0	13.3	12.0	10.9	10.0	9.2	8.6
	50	0.112	16.7	14.8	13.4	12.1	11.1	10.3	9.5
60	0.124	18.4	16.4	14.7	13.4	12.3	11.3	10.5	
Black (35)	10	0.070	10.4	9.2	8.3	7.6	6.9	6.4	5.9
	20	0.098	14.6	13.0	11.7	10.6	9.7	9.0	8.3
	30	0.120	17.9	15.9	14.3	13.0	11.9	11.0	10.2
	40	0.139	20.6	18.3	16.5	15.0	13.8	12.7	11.8
	50	0.156	23.1	20.6	18.5	16.8	15.4	14.2	13.2
60	0.170	25.2	22.4	20.2	18.4	16.8	15.5	14.4	
Brown (41)	10	0.094	14	12	11	10	9	9	8
	20	0.132	20	17	16	14	13	12	11
	30	0.162	24	21	19	17	16	15	14
	40	0.187	28	25	22	20	18	17	16
	50	0.209	31	28	25	23	21	19	18
60	0.228	34	30	27	25	23	21	19	
Orange (46)	10	0.119	18	16	14	13	12	11	10
	20	0.169	25	22	20	18	17	15	14
	30	0.207	31	27	25	22	21	19	18
	40	0.239	35	32	28	26	24	22	20
	50	0.267	40	35	32	29	26	24	23
60	0.293	43	39	35	32	29	27	25	
Maroon (52)	10	0.149	22	20	18	16	15	14	13
	20	0.210	31	28	25	23	21	19	18
	30	0.257	38	34	30	28	25	23	22
	40	0.296	44	39	35	32	29	27	25
	50	0.332	49	44	39	36	33	30	28
60	0.363	54	48	43	39	36	33	31	
Red (63)	10	0.218	32	29	26	24	22	20	18
	20	0.307	46	41	36	33	30	28	26
	30	0.376	56	50	45	41	37	34	32
	40	0.435	65	57	52	47	43	40	37
	50	0.486	72	64	58	52	48	44	41
60	0.532	79	70	63	57	53	49	45	
Blue (80)	10	0.351	52	46	42	38	35	32	30
	20	0.496	74	66	59	54	49	45	42
	30	0.608	90	80	72	66	60	56	52
	40	0.702	104	93	83	76	69	64	60
	50	0.785	117	104	93	85	78	72	67
60	0.859	128	113	102	93	85	79	73	
Yellow (95)	10	0.506	75	67	60	55	50	46	43
	20	0.715	106	94	85	77	71	65	61
	30	0.876	130	116	104	95	87	80	74
	40	1.009	150	133	120	109	100	92	86
	50	1.133	168	150	135	122	112	104	96
60	1.239	184	164	147	134	123	113	105	

All application rates (gallons/acres) are estimates based on 0-28-0 (10.65 lbs/gallon) at 70 degrees F

All application rates (gallons/acres) are estimates based on 0-28-0 (10.65 lbs/gallon) at 70 degrees F



Dual Metering Tube Plumbing Kits with Dual Check Valve

For more information, read [Navigating the Metering Tube Maze](#) or [Metering Tube / LiquiShiftTube Charts](#).

B

Components
Liquid

SureFire dual metering tube plumbing kits are a great way to plumb a planter to apply starter fertilizer. They'll also work on other implements when applying low rates or high rates of fertilizer.

These plumbing kits will contain everything you need to distribute fertilizer from the flowmeter outlet down to the ground application device of your choice (not included).

These instructions will show you where all the pieces go. It will provide guidance on how much metering tube to use. There are some optional fittings included in each plumbing kit. These instructions will show you where and why you'd want to use the optional pieces.

The dual check valve assembly is a key piece in the dual metering tube design. In addition to a check valve to stop fertilizer from draining when the system is shut off, **each check valve has an on/off valve on top of it. These on / off valves allow the operator to turn on only tube 1, only tube 2, or both tube 1 and 2. This provides for three different application ranges**, which is especially helpful when using Black Label Zn fertilizer (or any other liquid) which has a highly variable viscosity based on temperature changes.

Dual Advantage of Dual Metering Tube

Metering tube provides a larger passage-way diameter than a comparable orifice. For a 5 GPA rate on 30" rows, a size 0.046" orifice would be used. For the same rate a 0.110" meter tube that is 8' long would be used. This 8' tube with more than twice the diameter creates a fertilizer system resistant to plugging while providing excellent row to row distribution.

By using two metering tubes, the fertilizer system can handle Black Label ZN (or most other liquid solutions) and provide the proper system pressure as the fertilizer properties change due to temperature, mixtures and other factors.

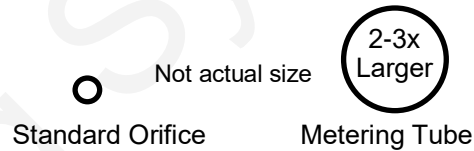

Field Operation of Dual Metering Tube - Dual Check Valve System

The dual metering tube allows for three application rate ranges. Some fertilizers can have a widely variable viscosity range. Therefore, based on temperature, tank mixing and fertilizer batch, the best tube to use will change.

SureFire recommends you start with the Green (or larger) tube ON only. This is the middle application range and is a good starting point. Conduct a test using the test speed mode to determine your system pressure. Recommended pressure is between 8 - 30 PSI. If pressure is below 8 psi, some check valves may not open and row to row distribution will be uneven. If pressure is too high, pump output will decrease and you may not reach the target rate.

Start with green (or larger) tube ON, blue tube OFF:

• **Pressure below 10 PSI: Turn green tube OFF and blue tube ON.**

Pressure over 30 PSI: Turn BOTH tubes ON.

(Other color tubes are available for different application rates.)

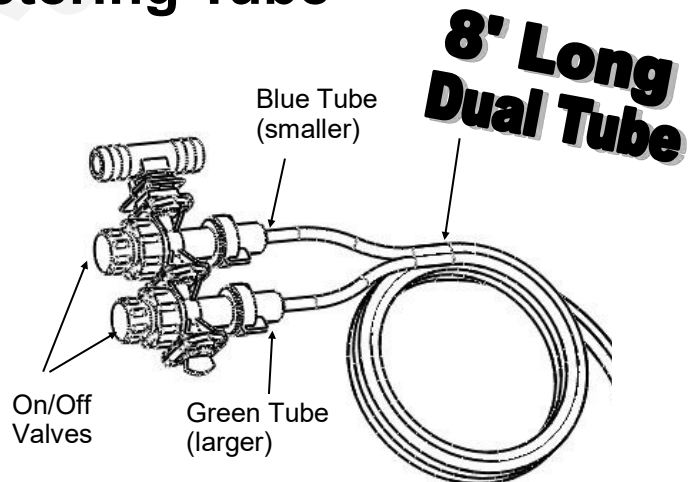

	GPA on 30" rows (approx, will vary)
Blue Tube	1.5 - 3
Green Tube	3 - 6
Blue & Green Tube	6 - 10
Minimum Recommended flow for Blue Tube (8 ft)	4 - 5 oz/min

** Ultra Low Rate Application –For rates from 2-5 oz/min/row use a 12 foot length of metering tube. To calculate oz/min/row: $Oz/min/row = (GPA \times MPH \times spacing \text{ (inches)}) \div 46.4$

Dual Check Valve Plumbing Diagram

4 Row Planter Shown, add rows as necessary

136-04-200400, Dual 4 PSI check valve with 1/4" QC caps and 3/8" FPT inlet

101-075075038-HBT-M-W 3/4" HB x 3/4" HB x 3/8" MPT Tee

113-19-025025025 Y Divider - 1/4" QC

Dual Metering Tube - 8 feet long

101-038075-90-W, 3/8" MPT x 3/4" HB - 90 degree

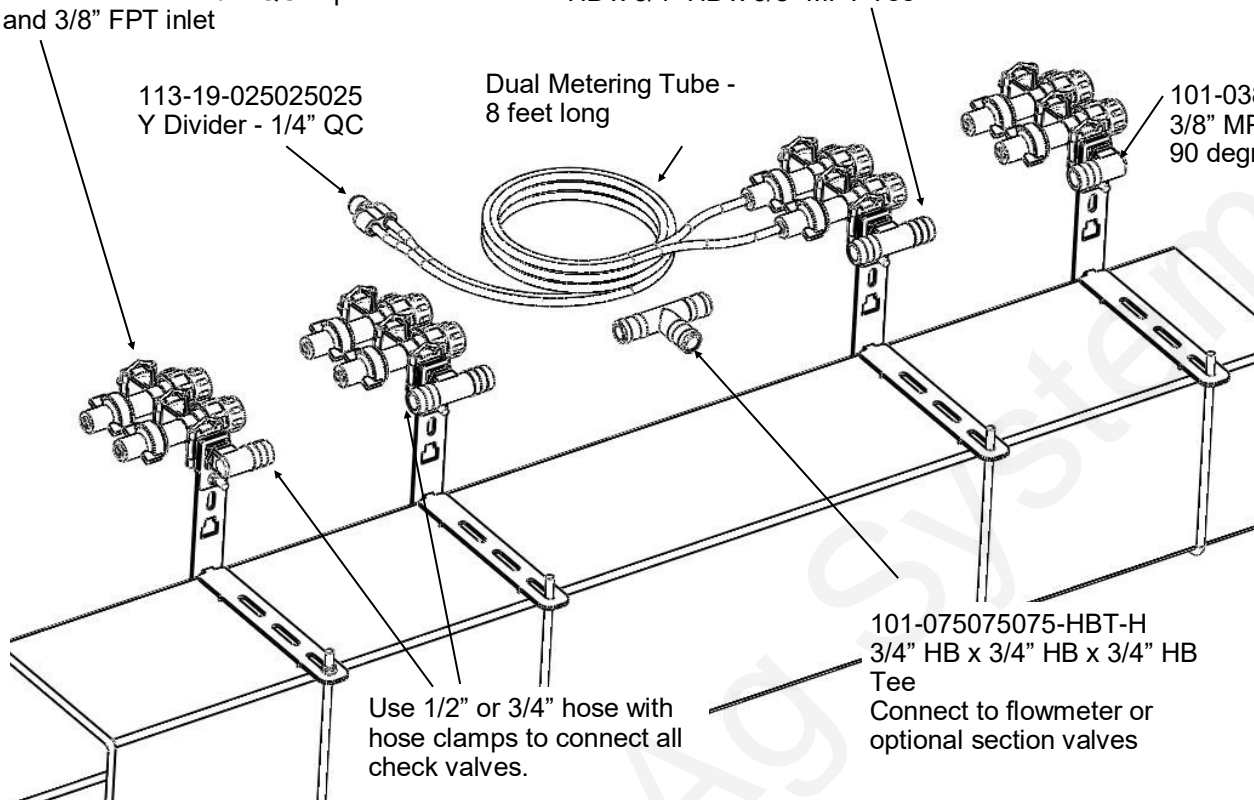

101-075075075-HBT-H 3/4" HB x 3/4" HB x 3/4" HB Tee
Connect to flowmeter or optional section valves

Use 1/2" or 3/4" hose with hose clamps to connect all check valves.

This is a general diagram showing the dual check valve assembly mounted on a planter toolbar. The check valve and bracket are very flexible in their mounting. The check valve can mount behind, directly over, or in front of the toolbar. The check valve can be put in the bracket facing up & down or sideways (shown). In addition the steel bracket could be rotated 90 degrees and clamp around the bar. The multiple slots in the bracket are used to mount to any tube 7x7 inches or smaller.

Sectional Plumbing Diagram with Dual Check Valves

12 Row Planter Shown

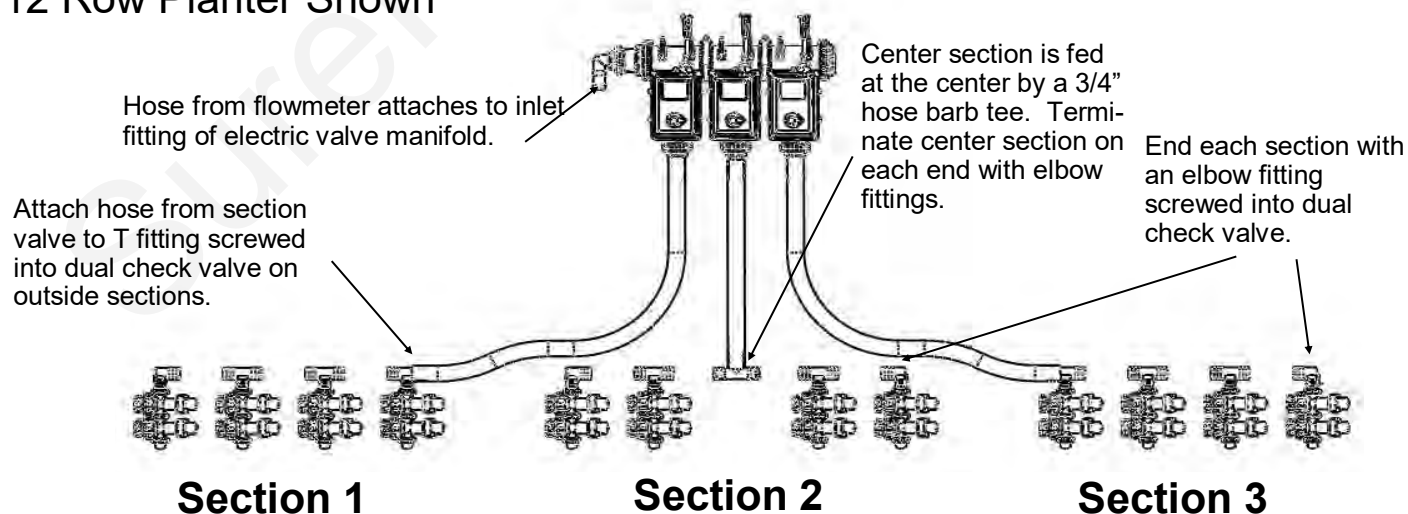

Hose from flowmeter attaches to inlet fitting of electric valve manifold.

Attach hose from section valve to T fitting screwed into dual check valve on outside sections.

Center section is fed at the center by a 3/4" hose barb tee. Terminate center section on each end with elbow fittings.

End each section with an elbow fitting screwed into dual check valve.

Section 1

Section 2

Section 3

For a **2 section plumbing system**, omit the center section and plumb similar to the outside 2 sections.

Dual Check Valve Assembly Steps

B
Components
Liquid

Follow these steps to mount each check valve to the steel bracket.

1. Screw the 3/8" MPT x 3/4" HB tee or elbow into the check valve using blue thread sealer. Orient the hose barb to run the 3/4" hose down the planter toolbar.
2. Insert the check valve into the "C" notch in the end of the bracket, according to how you want the check valve to be mounted on your planter. Orient the wire clips up or to the side for easiest access.
3. Slide the small "C" clamp bracket around the check valve to lock it in place.
4. Install the 1/4" carriage bolt and flange nut to secure the "C" clamp plate around the check valve.
5. Now, mount the check valve on the bar. Hold the check valve and long bracket assembly on the toolbar. Slide the tab on the front of the short bracket into the upper or lower notch on the long bracket.
6. Slide the L bolt into the appropriate slots on the brackets for your tube size. Tighten the 1/4" flange nuts to hold the bracket in place.

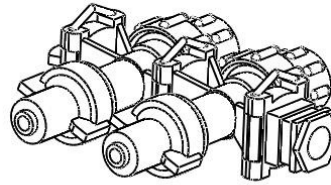

Clamp Bracket

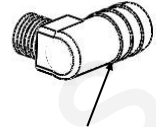
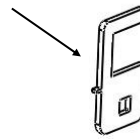

Elbow at end of section, Tee in mid-locations.

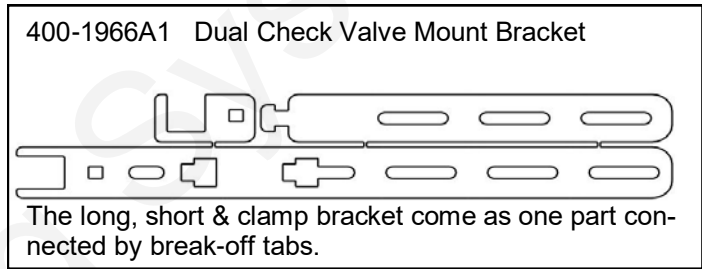

Check Valve Mounting Options

The dual check valve mounting bracket is very flexible to fit many different planter configurations. Three options are shown here to illustrate some of the possibilities.

Example 1. Use the long bracket on the top of a bar. The check valve is mounted vertically. The liquid supply hose is ran directly on the front side of the bar. The U-bolt is placed in slots to clamp on a 4x6 inch tube.

Example 2. Use the long bracket on the rear of a bar. The check valve is mounted over the top of the bar. The supply line would run above and behind the bar. The short bracket is placed in the notch to mount the check valve closer to the bar.

Example 3. Use the long bracket on the front of a 3x7 bar (vacuum tube on some planters). Mount the check valve hanging forward of the bar. The supply line will run directly over the bar. The excess bolt and bracket length can be cut off.

Short Bracket

Long Bracket

311-0408000800-05
1/4" L Bolt

Connection to Keeton Seed Firmer, Rebounder Seed Covers or through thin wall stainless steel tubes

1. Mount the Keeton Seed Firmer or Rebounder Seed Cover.
2. Route the tube included in the above kit as instructed.
3. Attach the 1/4" tube to the 1/4" QC Y divider fitting.
4. Zip all tubing to the planter and row unit in as many locations as possible.

For thin wall stainless steel tubes, you can push the 1/4" black tubing all the way through the stainless steel tube so fertilizer will run directly from the tubing onto the ground.

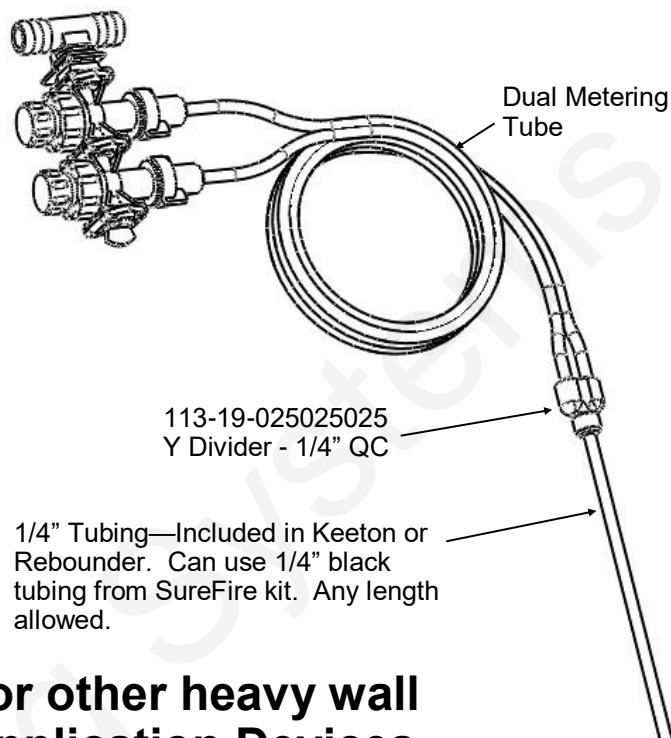

Connection to Totally Tubular or other heavy wall Stainless Steel Tube Ground Application Devices

When using a 3/8" OD stainless steel tube to apply fertilizer to the ground, there are two options for the delivery tube plumbing. If the tube ID is less than 1/4" (tubing will not fit inside tube) this attachment method must be used. The description following is for Option 1. See bottom right picture for Option 2.

1. Use the 1/4" x 3/8" QC fitting shown. Push the 3/8" end onto the stainless steel tube. (Hint: if the fitting slips off the stainless steel tube, use sandpaper or a file to roughen the end of the tube slightly)
2. Use a short piece of 1/4" black tubing to connect the Y fitting to the reducer fitting on the stainless steel tube.
3. Zip all tubing to the planter and row unit in as many locations as possible.

Option 1: QC Fitting attaches to SS Tube

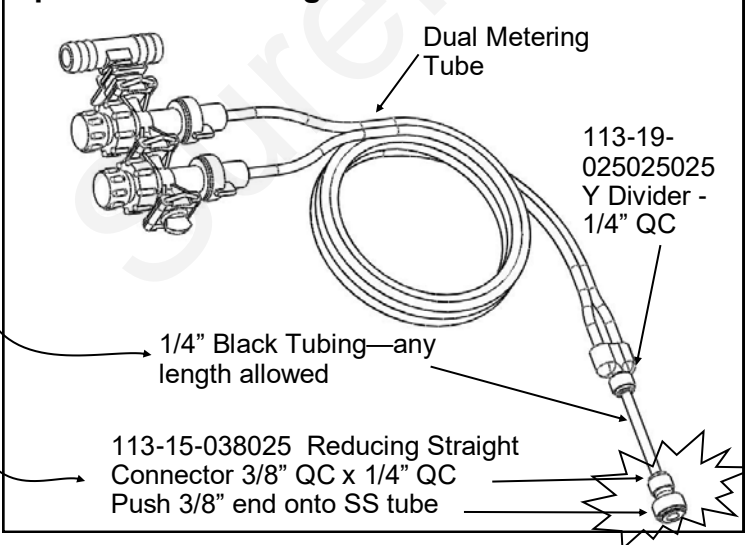

Option 2: 3/8" Hose attaches to SS Tube

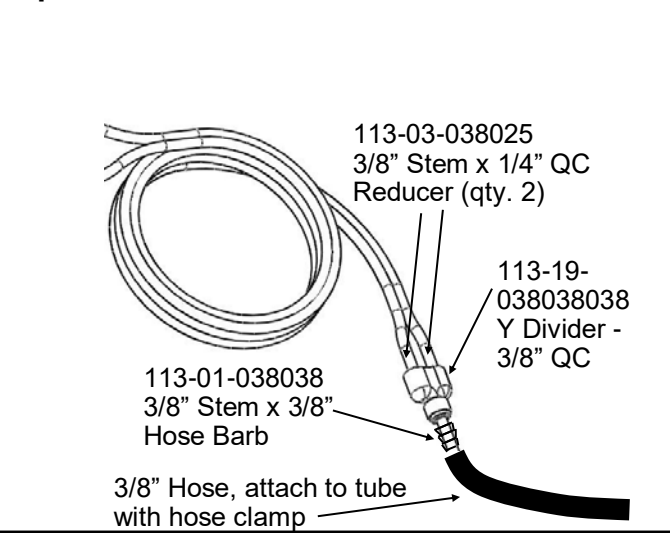

John Deere GreenStar Rate Controller (GRC) for GS2 & GS3



SureFire Fertilizer Systems begin at the John Deere Rate Controller, which you will need to purchase from your John Deere dealer. The picture below shows the John Deere Rate Controller. A John Deere Rate Controller can control one product. Therefore, if you are applying two liquid fertilizers on your planter, you will need three rate controllers, one for seed and two for liquid fertilizer. The John Deere Rate Controller communicates with the John Deere GS2 or GS3 display in the cab.

The harness coming from the rate controller is a 37-pin Amp connector. SureFire Fertilizer System harnesses begin at this 37-pin connector. The following page shows a system layout to illustrate how the harnessing is connected to all components. Detailed harness drawings follow for information and troubleshooting.

Instructions for setting up the GS2 or GS3 display are in Section F. Detailed screen shots of the display are included showing exactly what settings are required and recommended for SureFire Fertilizer Systems.

See your John Deere Rate Controller Operator's Manual for more setup and operating instructions.

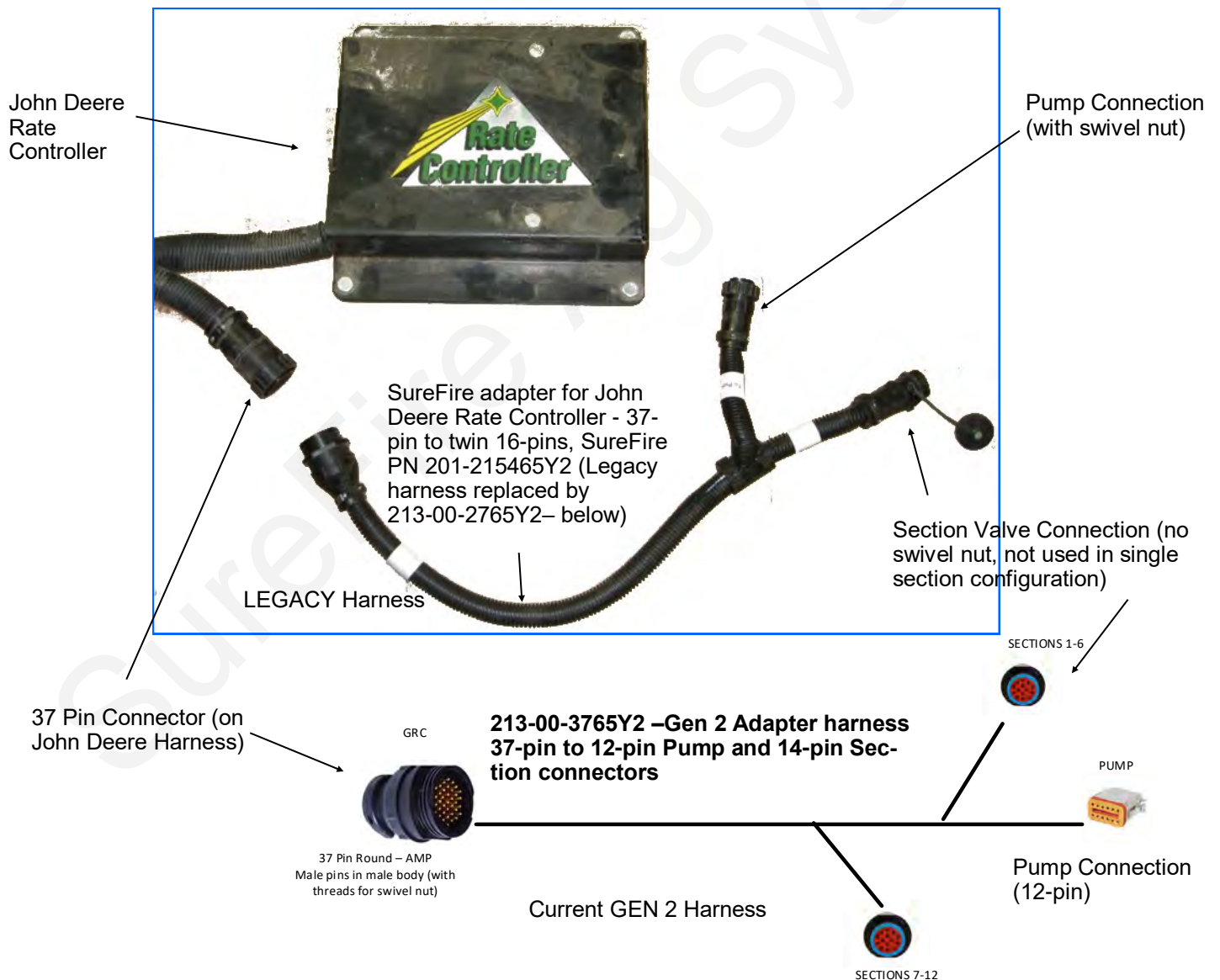

Tower & John Deere Rate Controller Layout

Control: PWM EPD

Sections: 3

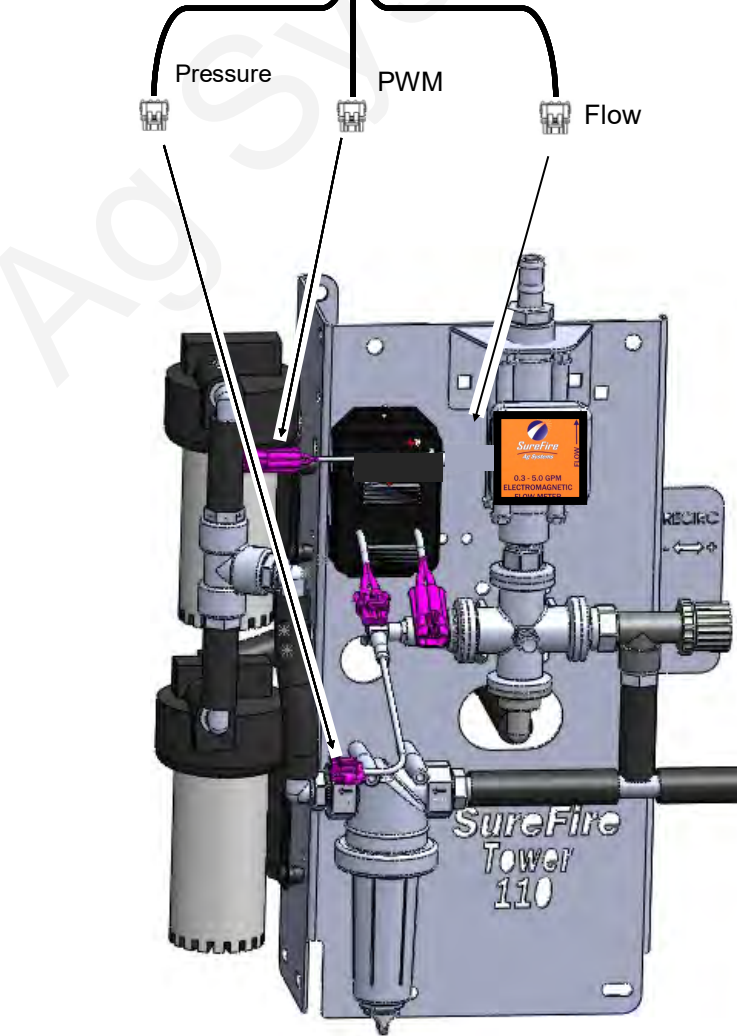
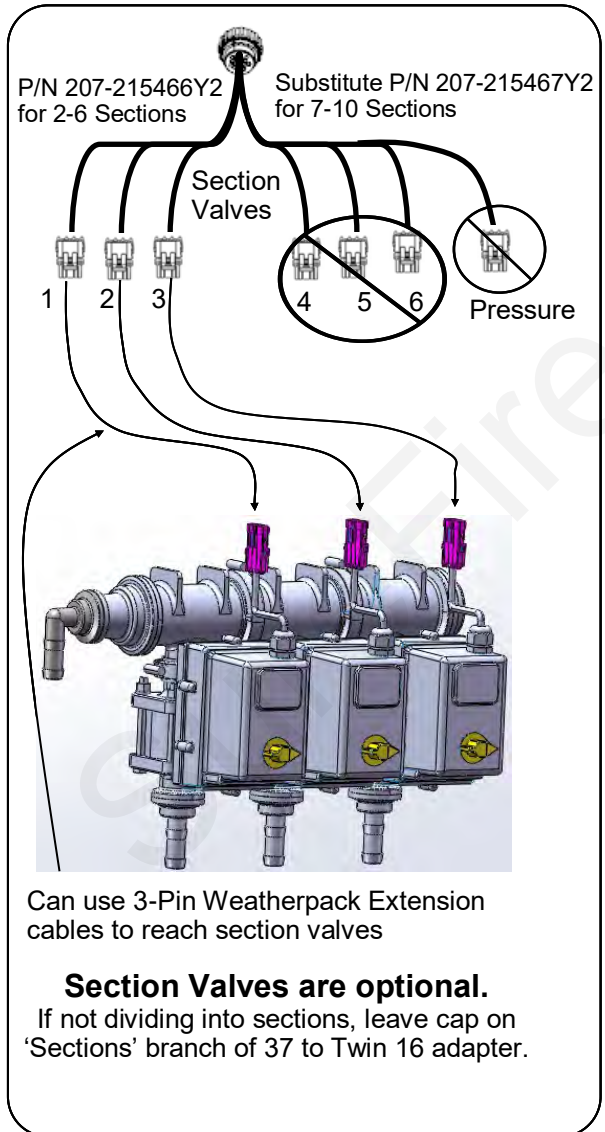
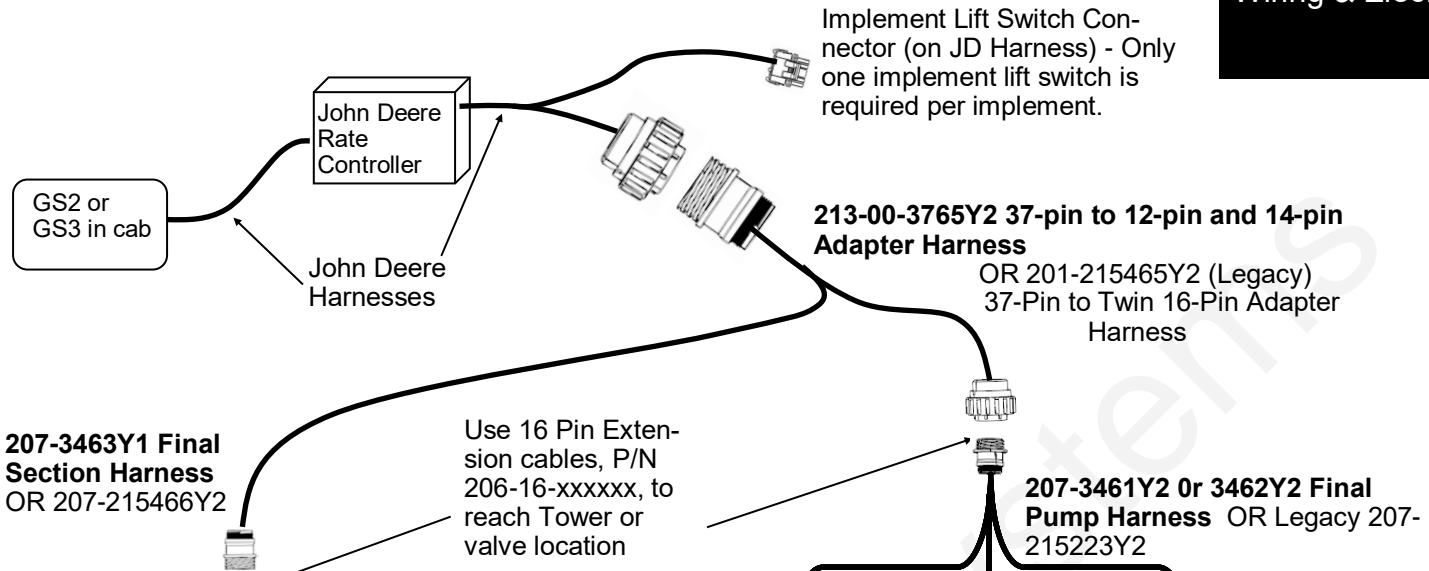

Means connector not used in this configuration.

40 Amp PWM EPD (Pulse Width Modulated Electric Pump Driver) Item Number: 205-19024 with Anderson connectors (replaces 205-18385 with 480 MP connectors)



The Electric Pump Driver powers 1 or 2 electric pumps by providing a pulse width modulated signal to control pump speed. It needs to have a power connection and wiring capable of carrying up to 40 amps of current. **It must be connected directly to the tractor battery.** SureFire recommends 8 gauge wire (or heavier) if extending harnesses in the field.

205-19024

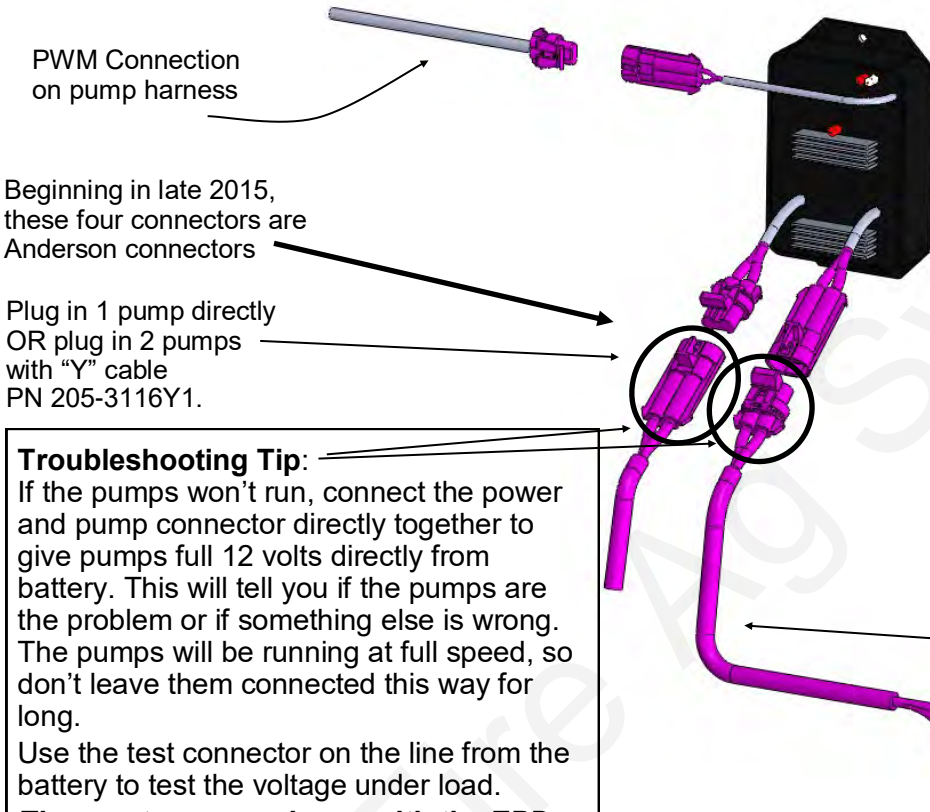
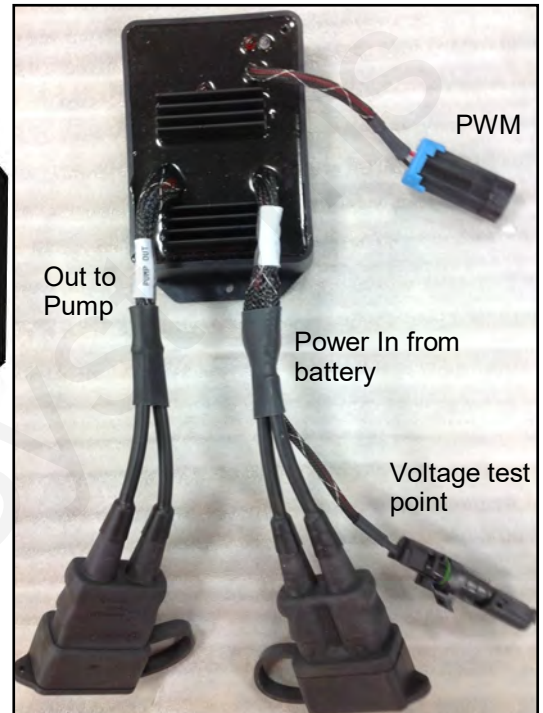

Troubleshooting Tip:
If the pumps won't run, connect the power and pump connector directly together to give pumps full 12 volts directly from battery. This will tell you if the pumps are the problem or if something else is wrong. The pumps will be running at full speed, so don't leave them connected this way for long.
Use the test connector on the line from the battery to test the voltage under load.
The most common issue with the EPD will be a low voltage condition (under load) delivered to the EPD from the battery. Voltage drop occurs anytime current is moved through a wire. A low-voltage (12 v) system with long runs (60-80 feet) may have unacceptable voltage drops if any part of the system is weak or the load is high. This could be bad (corroded, weak, loose or burnt) connectors (at the battery, at the hitch, and at the EPD), too small of wire used (smaller wire equals more voltage drop), low source voltage, and heavy load. Any or all of these may contribute to a low voltage condition under load that may shut down the processor in the EPD module. This will be indicated by 4 quick flashes of the red light, followed by a short pause. Unplug the power-in connector to reset the EPD.

EPD Power Harness PN 205-3118Y1 (20 feet) - **connect to tractor battery.** This is 6 AWG wire.
40 Amp in-line fuse

Use EPD Power Harness Extensions as needed (These have Anderson Connectors)

Part Number	Description	Wire Size
206-02-3120Y1	1' Extension	10 gauge
206-02-3121Y1	5' Extension	10 gauge
206-02-3122Y1	10' Extension	8 gauge
206-02-3123Y1	20' Extension	8 gauge
206-02-3124Y1	30' Extension	30' and longer—6 gauge
206-02-3125Y1	40' Extension	
206-02-3126Y1	50' Extension	
206-02-3127Y1	60' Extension	
206-02-3128Y1	2' Anderson Ext w/ Power Switch-8 AWG	

SureFire recommends a single long extension harness as multiple connectors will reduce voltage, increase current and hurt performance of your electric pump system.

John Deere GreenStar Rate Controller Wiring Schematics



Your John Deere system may have one of the following two sets of harnesses. The first set was introduced during the 2018 season. The second set is the legacy set that has been used for several years.

New JD GreenStar Rate Controller (GRC) harnesses for the 2018 season:

Adapter Harness

213-01-3765Y2 JD Rate Controller Adapter harness with 12-pin Product and 14-pin Section connectors

Pump Harness

207-3461Y2 12-pin Final Cable for Tower with 1 or 2 Section Valves (PWM, Flow, Pressure, Sections 1 and 2)

Or
207-3462Y2 12-pin Final Cable for SureFire Liquid System (PWM, Flow, Pressure, Pump RPM)

Section Harness (if needed)

207-3463Y1 14-pin 6-section Final Cable

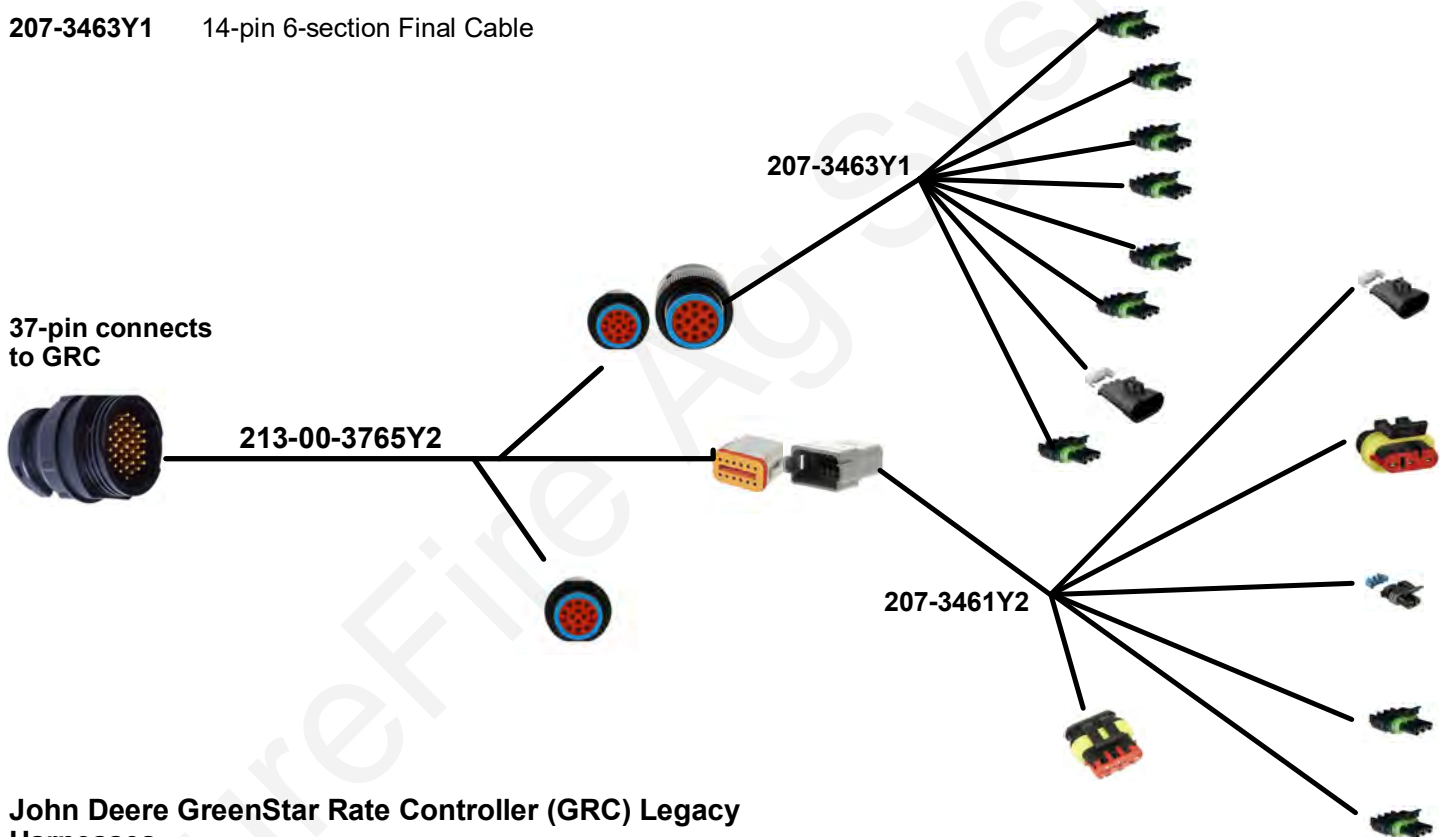

John Deere GreenStar Rate Controller (GRC) Legacy Harnesses

Adapter Harness

201-215465Y2 JD Rate Controller to twin 16-pin AMP connectors

Pump Harness

207-215223Y2 PWM Pump Cable (alternate 207-3057Y1)

Section Harness

207-215466Y2 16-pin 6-Section Harness

213-00-3765Y2

Rate Controller Adapter Cable 37-pin to 12-pin Product and 14-pin Sections

Wire 18AWG
unless otherwise
specified

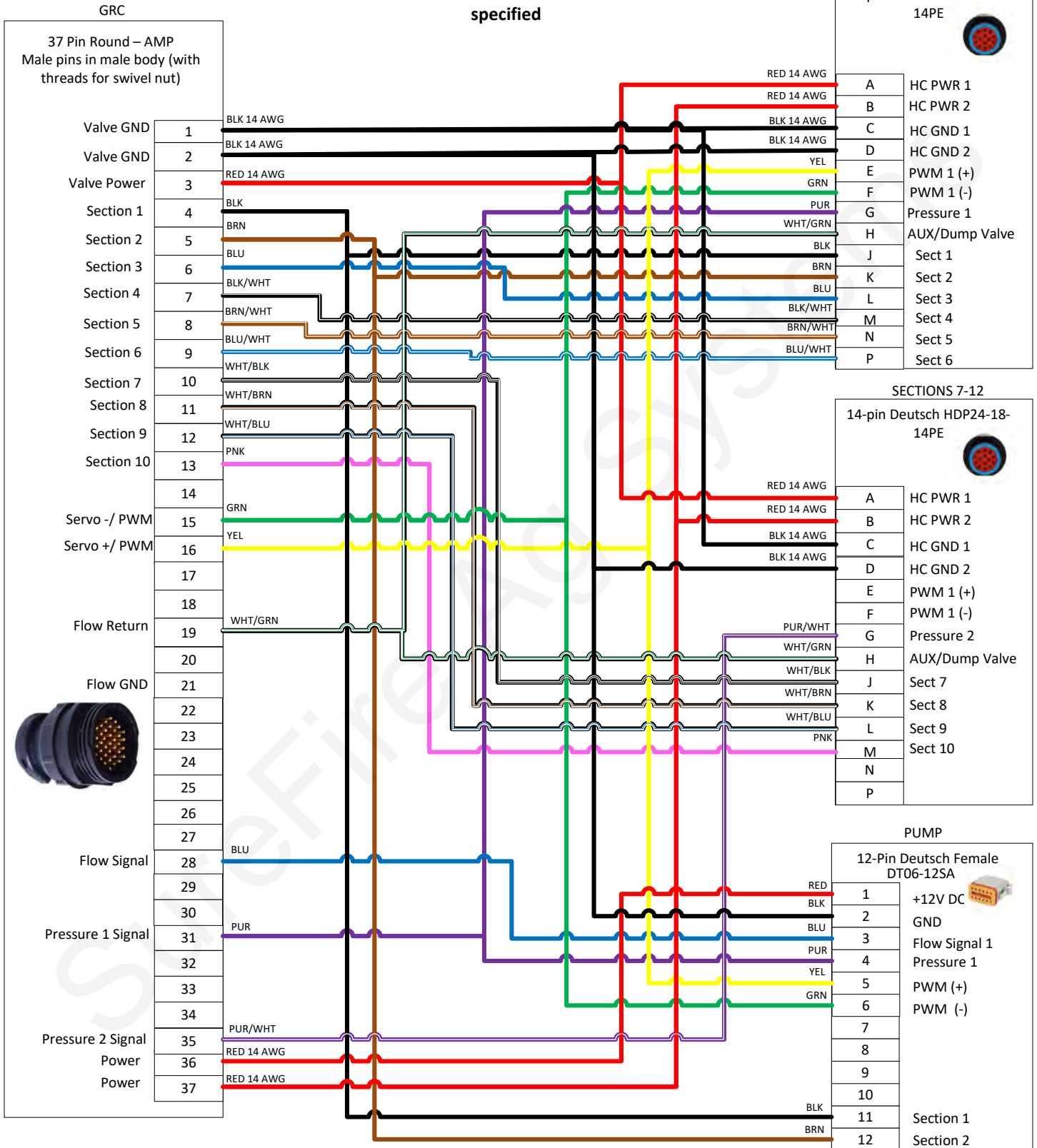

Part No:	213-00-3765Y2		Drawn By:	Mark Wolters		
Description:	Rate Controller Adapter Cable 37-pin to 12-pin Product and 14-pin Sections		Last Edit Date:	10/12/2018	Revision	A-01
Copyright 2017 SureFire Ag Systems, Reproduction or other use of drawing without express written permission from SureFire Ag Systems is forbidden			23			

207-3461Y2

Final Cable for Tower With 1-2 Section Valves (pwm, flow, pres., sec 1, sec 2, fill flow)

**Wire 18AWG
unless otherwise
specified**

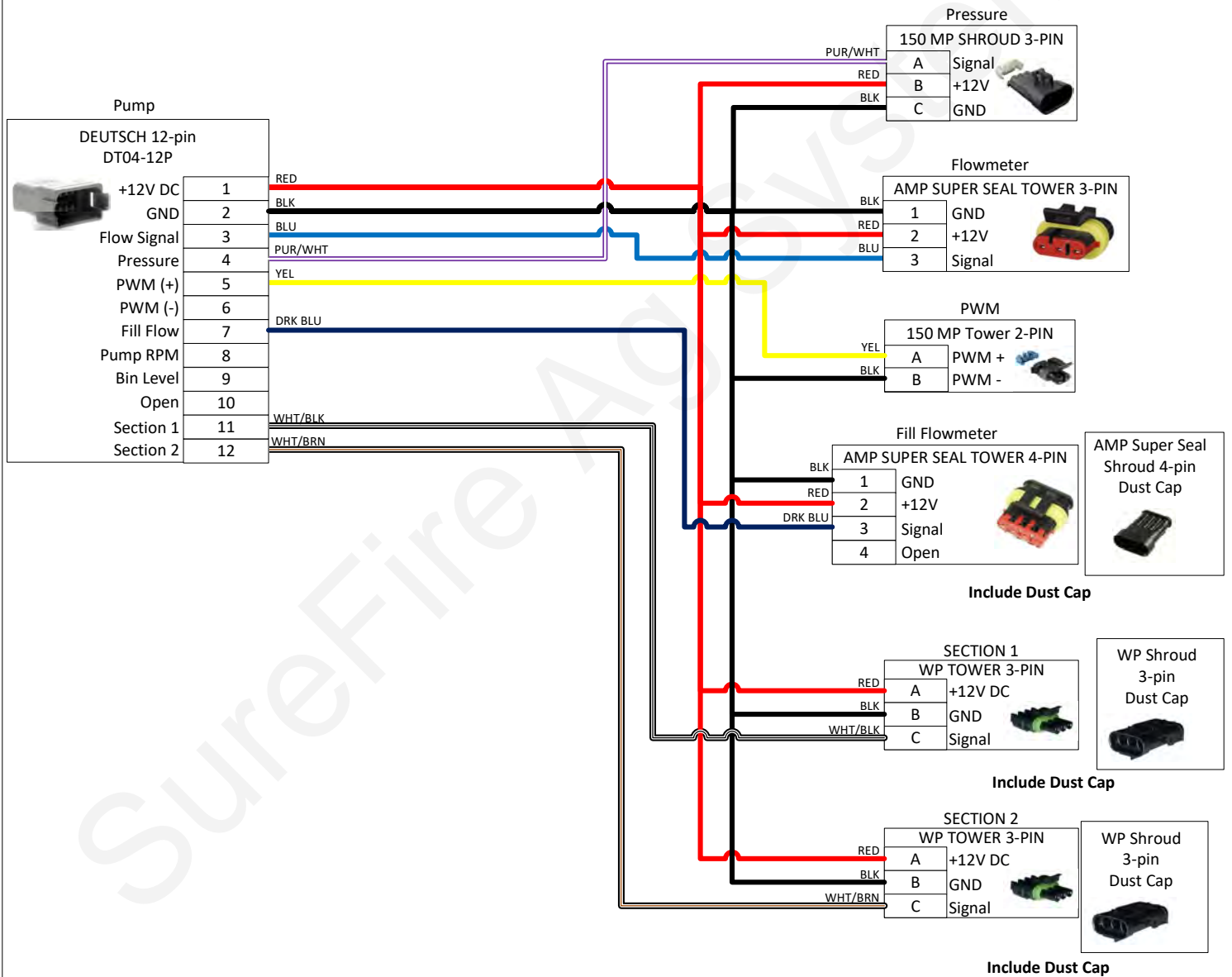

	Part No:	207-3461Y2	Drawn By:	Brandon Cavenee		
	Description:	Final Cable for Tower With 1-2 Section Valves (pwm, flow, pres., sec 1, sec 2, fill flow)	Last Edit Date:	4/3/2019	Revision	A-03
	Copyright 2018 SureFire Ag Systems, Reproduction or other use of drawing without express written permission from SureFire Ag Systems is forbidden			24		

207-3462Y2

Final Cable for SureFire Liquid Pump System (pwm, flow, pres., pump rpm, fill flow)

**Wire 18AWG
unless otherwise
specified**

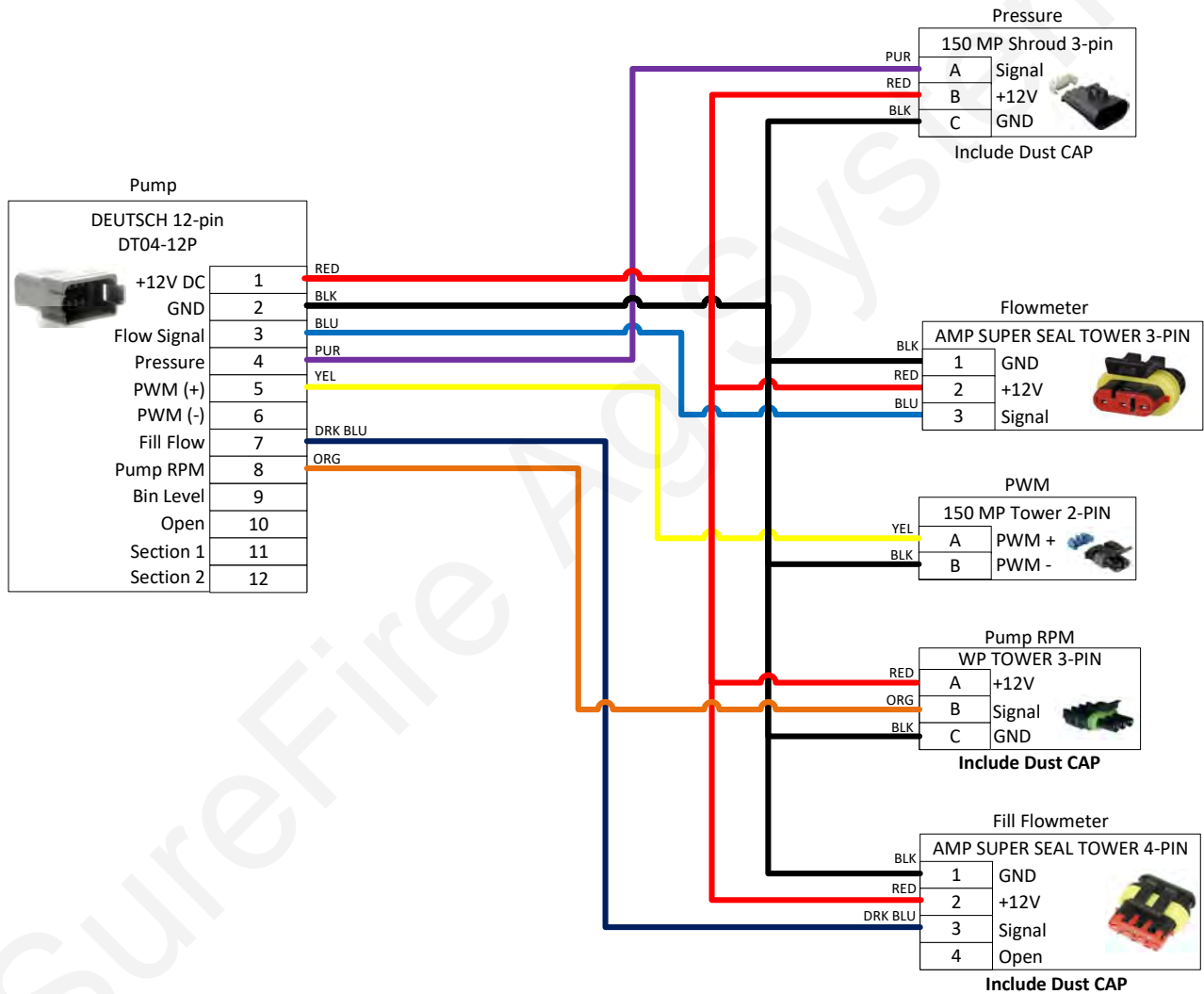

	Part No:	207-3462Y2	Drawn By:	Brandon Cavenee		
	Description:	Final Cable for SureFire Liquid Pump System (pwm, flow, pres., pump rpm, fill flow)	Last Edit Date:	9/4/2018	Revision	A-02
	Copyright 2018 SureFire Ag Systems, Reproduction or other use of drawing without express written permission from SureFire Ag Systems is forbidden			25		

207-3463Y1

14-Pin 6 Section Final Cable (6 sections, flow return, pressure)

**Wire 18AWG
unless otherwise
specified**

Provide dust caps for WP and MP connectors

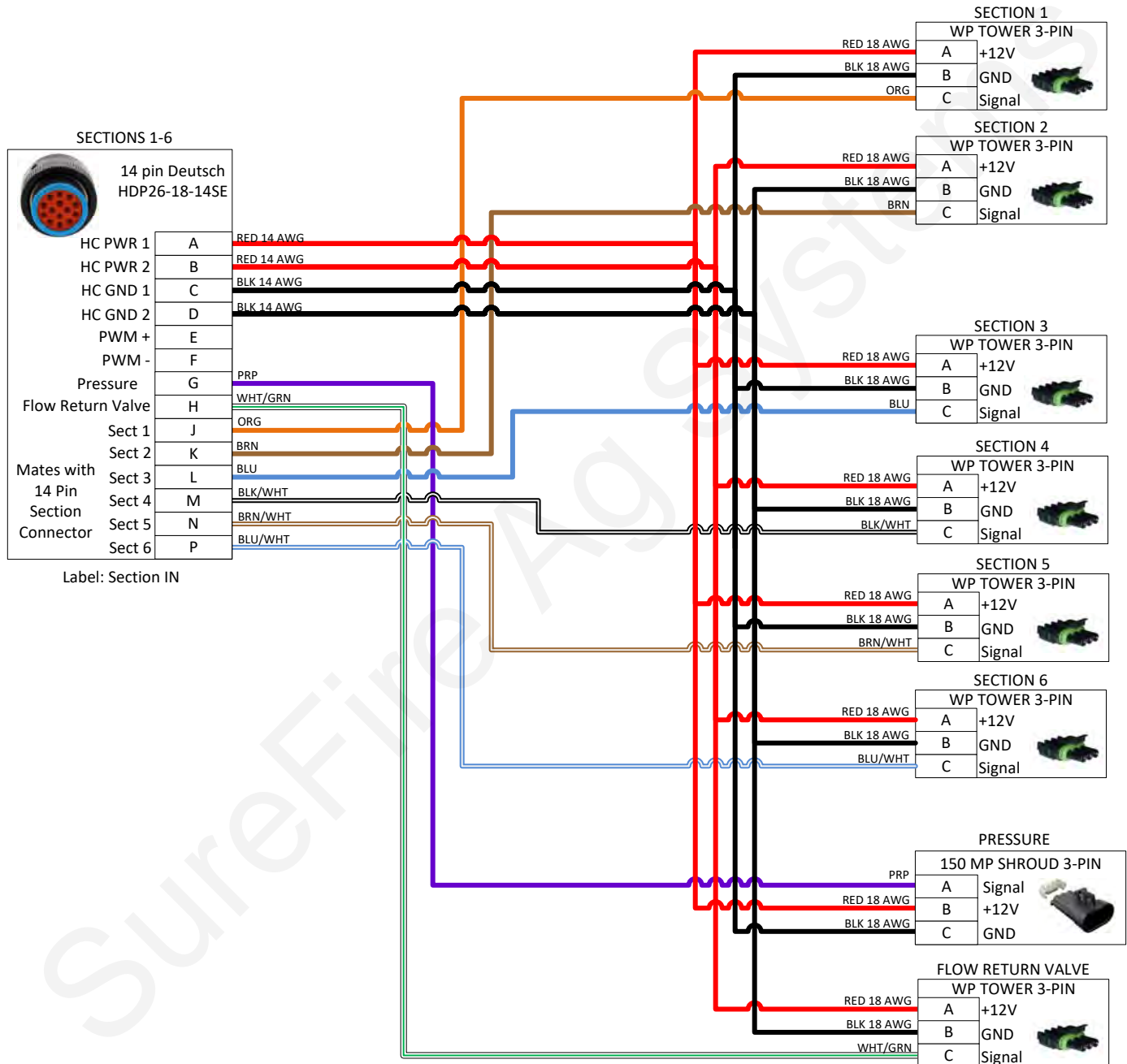

	Part No:	207-3463Y1	Drawn By:	Brandon Cavenee		
	Description:	14-Pin 6 Section Final Cable (6 sections, flow return, pressure)	Last Edit Date:	11/2/2016	Revision	A-01
	Copyright 2016 SureFire Ag Systems, Reproduction or other use of drawing without express written permission from SureFire Ag Systems is forbidden			26		

Wire Size: 18 AWG unless otherwise specified

201-215465 Y2

GS2 Adapter Cable – 37 pin to twin 16 pins

Length: 2ft

37 Pin Round – AMP
Male pins in male body (with threads for swivel nut)

Sections

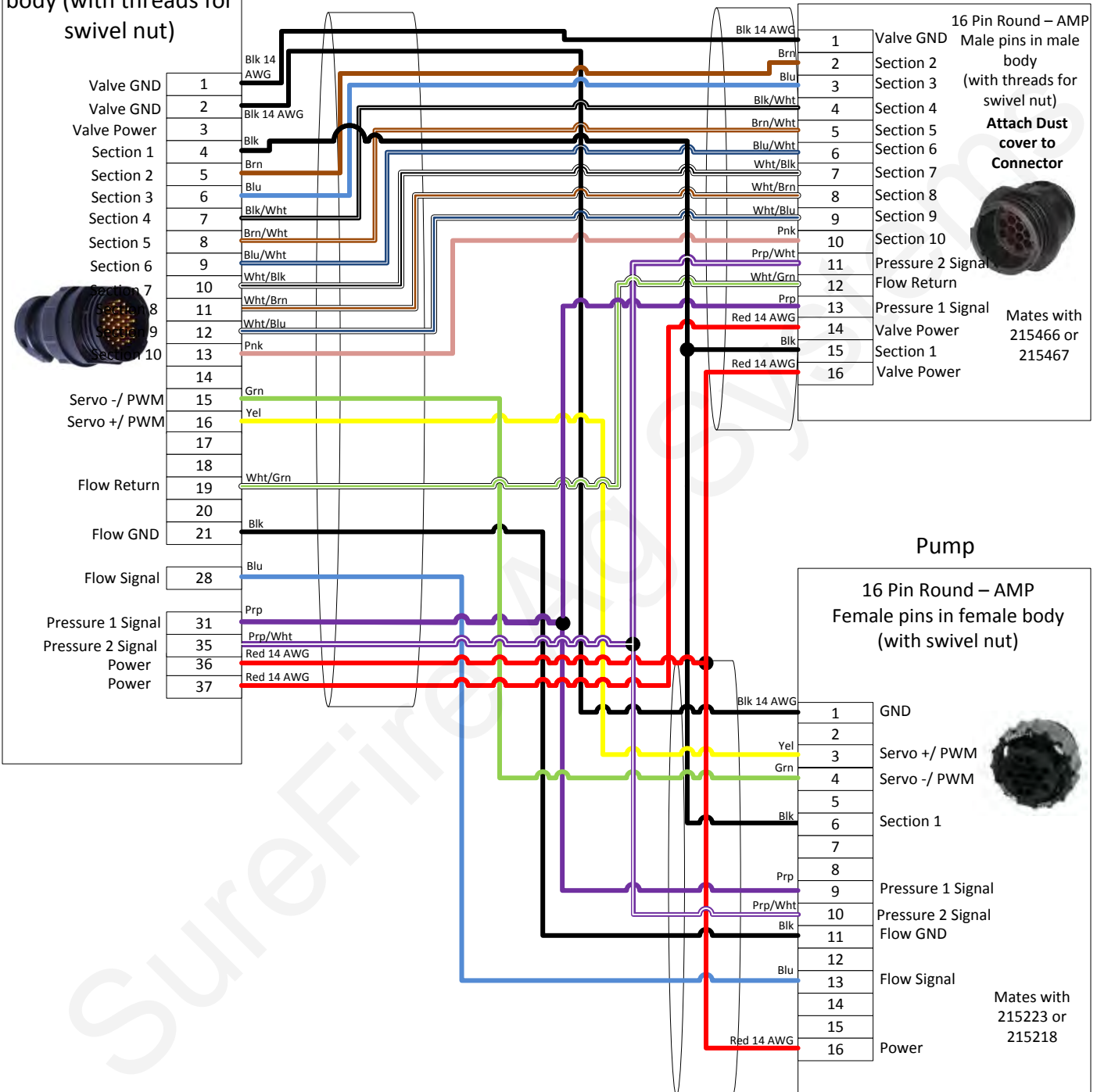

Mates with 215466 or 215467



Mates with 215223 or 215218

Pump

16 Pin Round – AMP
Female pins in female body (with swivel nut)



Project:	201-215465 Y2 with 2 pressure and Flow Return	Drawn By:	Dirk Ricker Rev by Mark Wolters
Filename:	GS2 Adapter Cable – 37 pin to twin 16 pins	Date:	9/12/2012 Rev 08/27/13
Copyright 2012-2013 SureFire Ag Systems		27	

PWM Pump Cable - Flowmeter, PWM and Pressure

207-215223Y2

Wire Size: 18 AWG

16 Pin Round – AMP
Male pins in male body
(with threads for swivel nut)



PWM
150 MP
TOWER
2-PIN

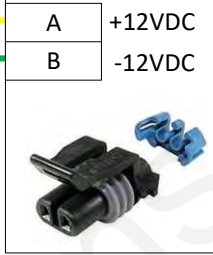

PRESSURE 1

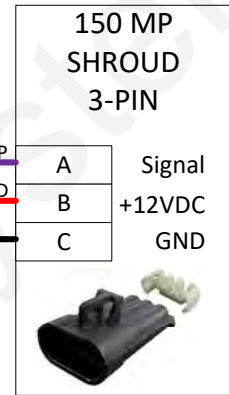

PLUG
(PRESSURE)

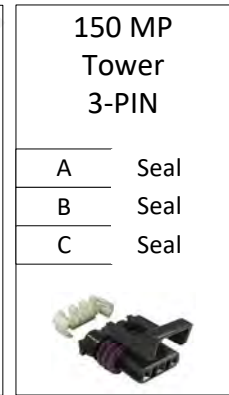

150 MP
Tower
3-PIN

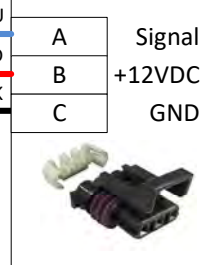

FLOW
Meter

PRESSURE 2

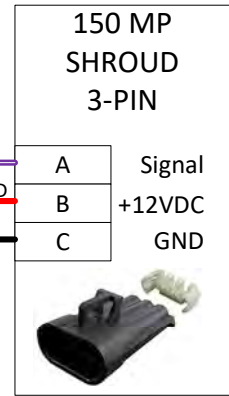

PLUG
(PRESSURE)

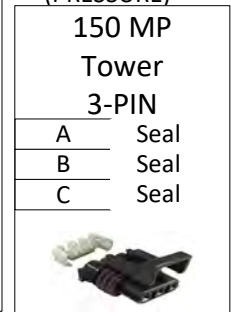

Part No:	PWM Pump Cable - Flowmeter, PWM and Pressure	Drawn By:	Brady		
Description:	207-215223Y2	Last Edit Date:	1/22/2019	Revision	A-01
Copyright 2019 SureFire Ag Systems, Reproduction or other use of drawing without express written permission from SureFire Ag Systems is forbidden		28			

207-215466 Y2

6 Section Boom Harness w/ 2 Pressure and Flow Return Valve

All wire gauge 18 AWG
Unless Specified

Wire Length: 10'

Put booms 1-6, Flow Return and Pressure 1-2 in one loom 10' long

Provide dust caps for WP and MP connectors

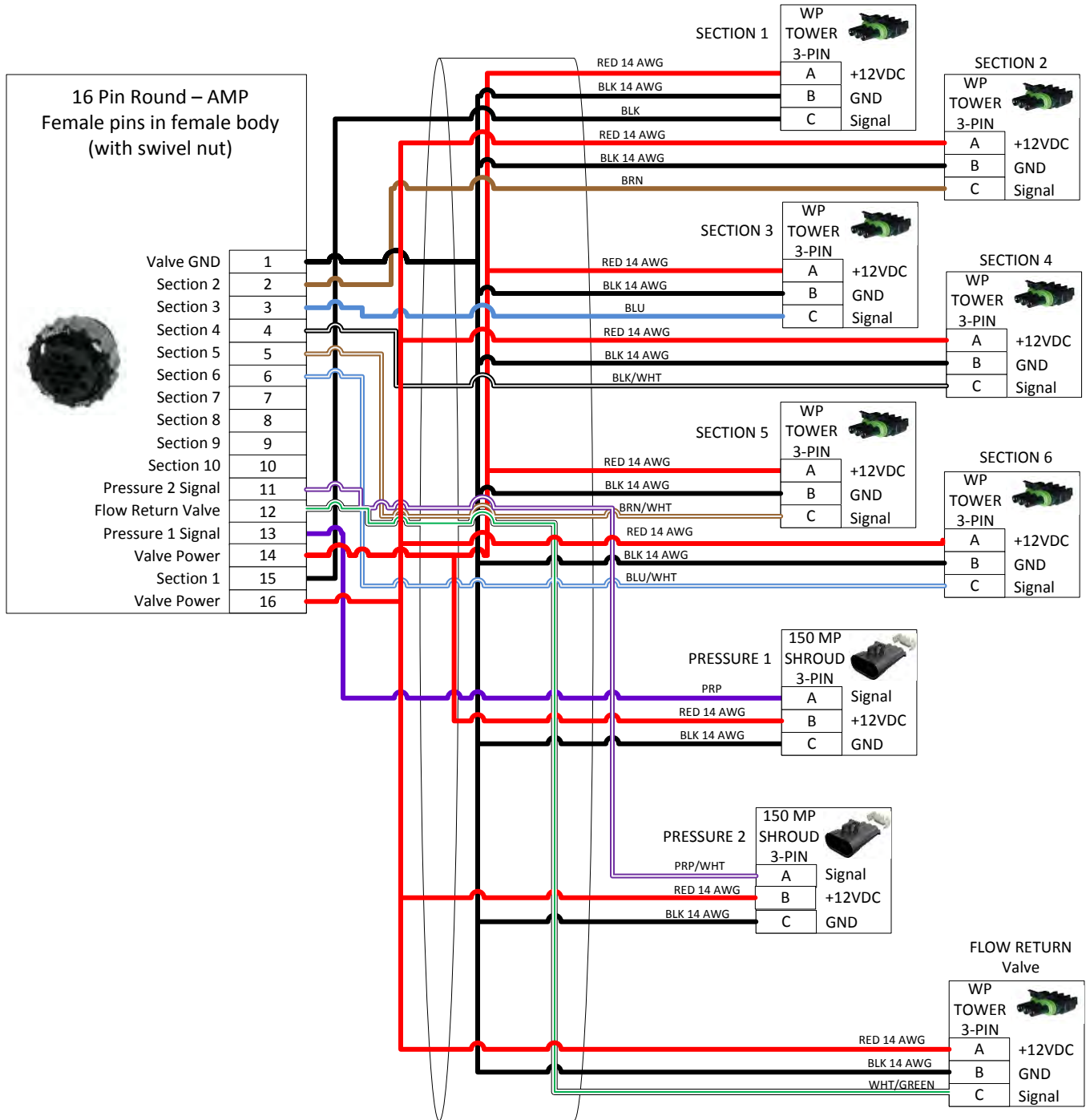

Project:	207-215466 Y2	Drawn By:	Dirk Ricker Rev. by Mark Walters
Filename:	6 Section Boom Harness w/ 2 Pressure and Flow Return	Date:	9/12/2012 08/20/2013
Copyright 2012-2013 SureFire Ag Systems		29	

Floating Ball Flow Indicators

Flow Indicators are extremely flexible and can be mounted in hundreds of different configurations on various types of liquid application equipment. This page is to give you some ideas and let you customize the installation for what works best on your equipment.

E Installation Overview

16 Row

Split 6 - 4 - 6

This configuration works well on a 16 row front fold planter. Each flow indicator manifold is shown fed by a cross in a single section installation. Each manifold could be fed by a section valve if desired.

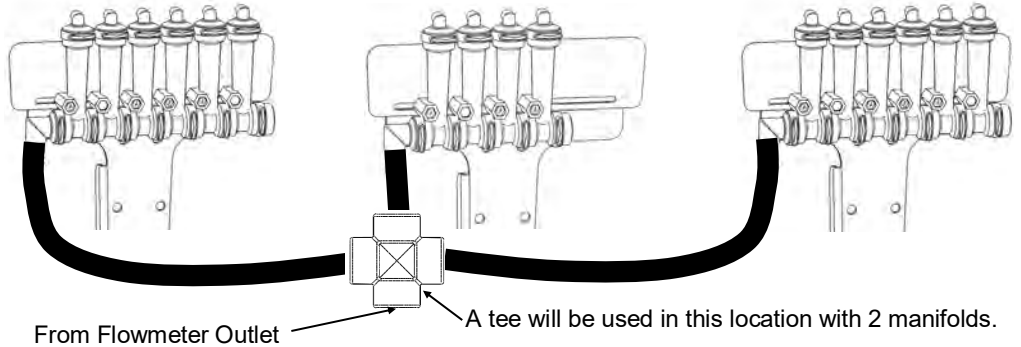

12 Row

Split 3 - 3 - 3 - 3

Shown here is a 12 row with four 3 row sections controlled by four section valves. Note each 6 row T-Bracket can hold two separate 3 row manifolds.

A 4 section 24 row could be similar with four 6 row manifolds on two large T-Brackets.

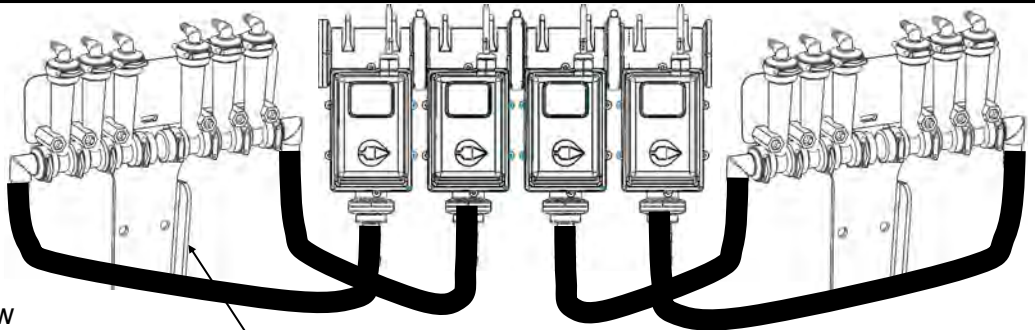

NOTE: Another option is the flange can face forward so the T-Bracket could be mounted on the front side of a bar.

12 Row Dual Product

Product 1 Split 4 - 4 - 4 / Product 2 Split 4 - 4 - 4

In this case each manifold would be fed by a section valve. There would be 6 total section valves (3 sections X 2 products). Most often one set (top) of flow indicators would be Full Flow for high rate fertilizer and 2nd set (bottom) would be Low Flow for starter.

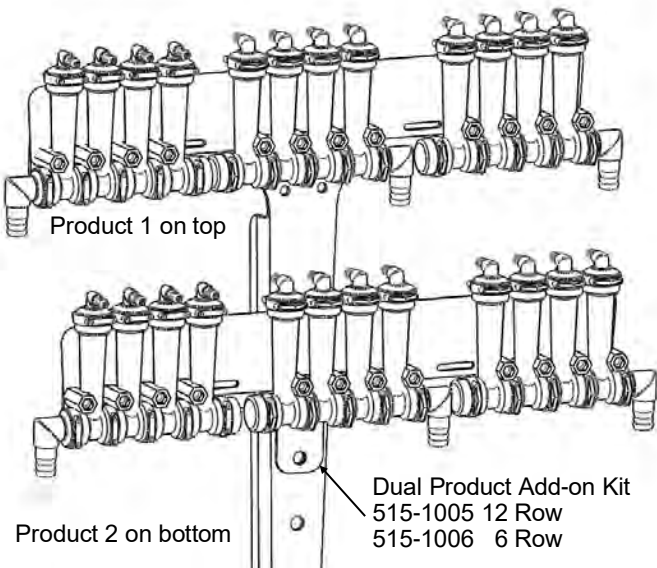

General Plumbing Guidelines

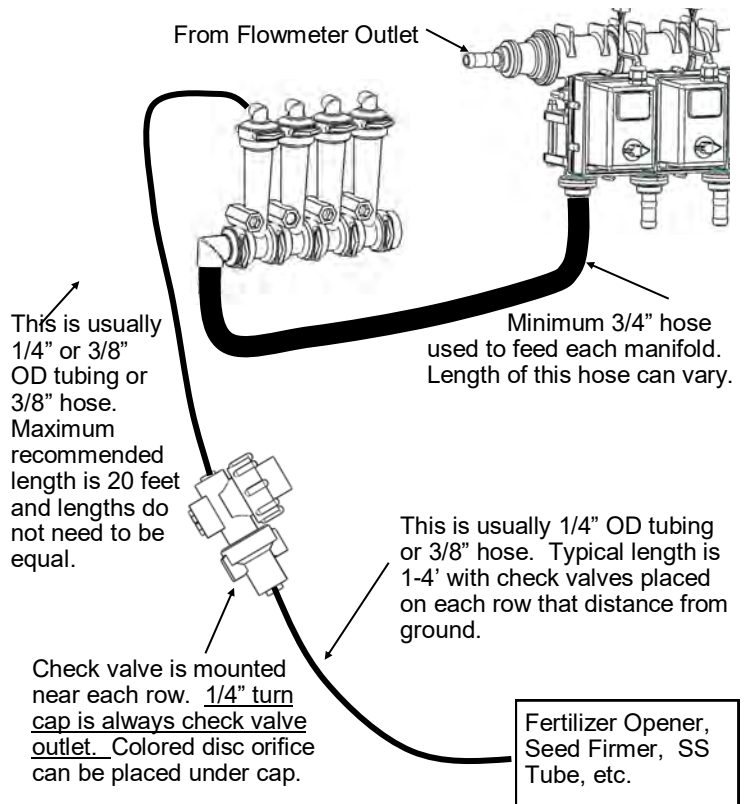

Tower 110 & 200 Mounting Options

Tower Basic Mounting Bracket
Item Number:
511-1007 (8x16 hitch)
511-1008 (8x12 hitch)

This kit includes a bracket to mount to the top side of a bar or hitch and mount the tower directly over that bar. It is often used on front fold planter hitches. U-bolts to mount to two common hitch sizes are included in the kits as labeled above.

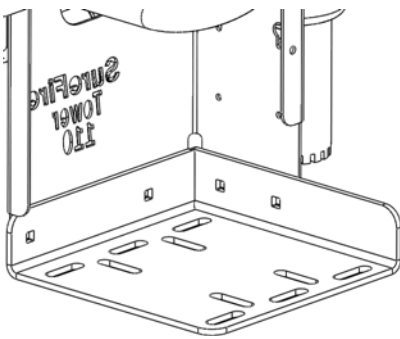

Tower Offset Mounting Bracket
Item Number 511-1010

The Tower is available as a stand alone item. This kit includes a bracket to mount to the top side of a bar and hold the Tower. U-bolts are NOT INCLUDED. They must be ordered separately based on mounting bar size. Multiple slots allow the Tower to be mounted away from or directly over the bar.

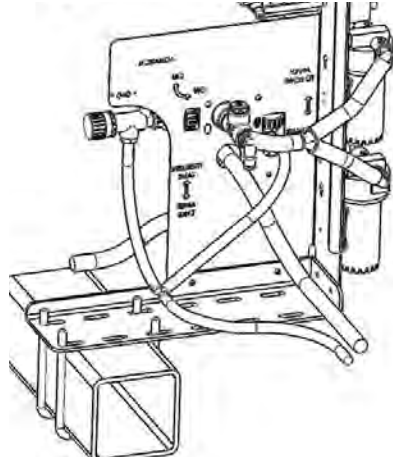

Tractor Front Mount Elliptical Cradle Tower Mounting Bracket
Item Number 511-1009

Mounts a Tower directly to the front of tractor front mount 200 & 300 gallon elliptical tank cradles. This bracket will mount the back of the tower just over 4 1/2" forward of the flat bracket mounting face. When using a tractor mounted tank, SureFire recommends mounting the Tower near the tank, not back on the implement. Electric pumps work better to push the liquid than to suck the liquid a long distance into the pump inlet.

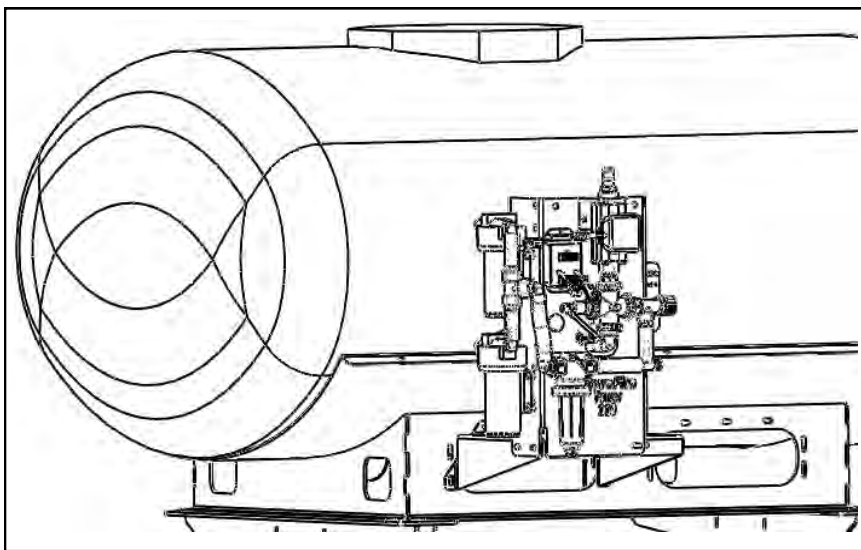
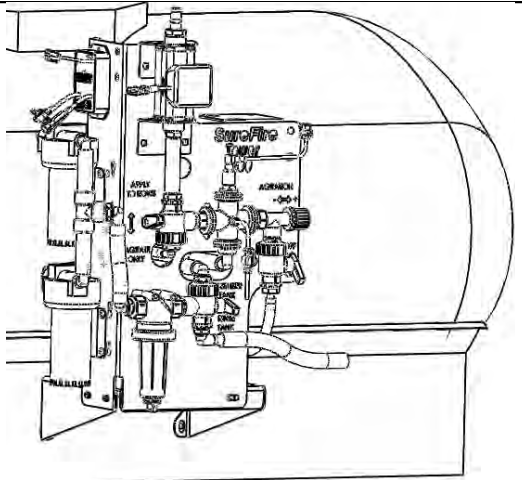

500 Gallon Elliptical Cradle Tower Mounting Bracket
Item Number 526-10-200500

Mounts a Tower directly to the side of the SureFire 500 gallon elliptical tank cradle. This bracket will mount the back of the tower just over 9" forward of the flat bracket mounting face.

Accelerator with Tower 200 Pump Panel



The Accelerator is a completely assembled and tested fertilizer system. It has a 55, 110, or 155 gallon tank resting in a custom molded tank base that doubles as a rinse water tank. This bolts to a steel frame with eighteen 5/8" mounting slots for flexible mounting to fit many situations. The Tower 200 is often used with the accelerator to work with the rinse tank base.

Dimensions:

- 55 Gallon: 27" W x 54" L x 36" T
- 110 Gallon: 28" W x 72" L x 36" T
- 155 Gallon: 28" W x 72" L x 46" T

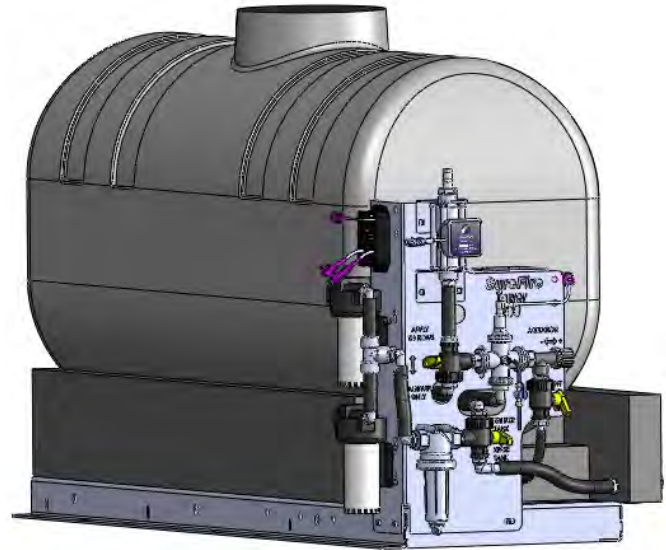

Accelerator Z Mount Kit (fits 5" to 7" wide bars, included bolts fit 7" tall bar) Item Number 526-01-100300

This mount kit includes two welded brackets to mount any of the 3 sizes of accelerator tanks above and offset from the 7x7 planter toolbar as shown.

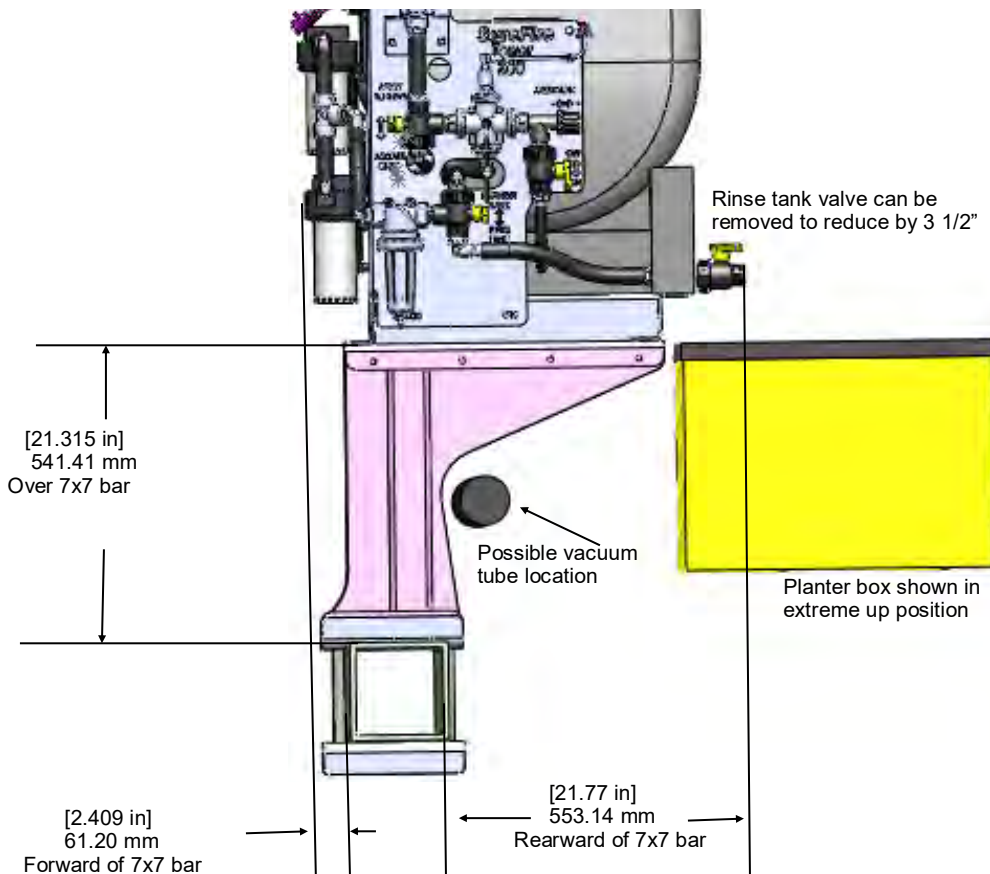

Tower 110 Plumbing Overview & Valve Operation

E

Installation
Overview

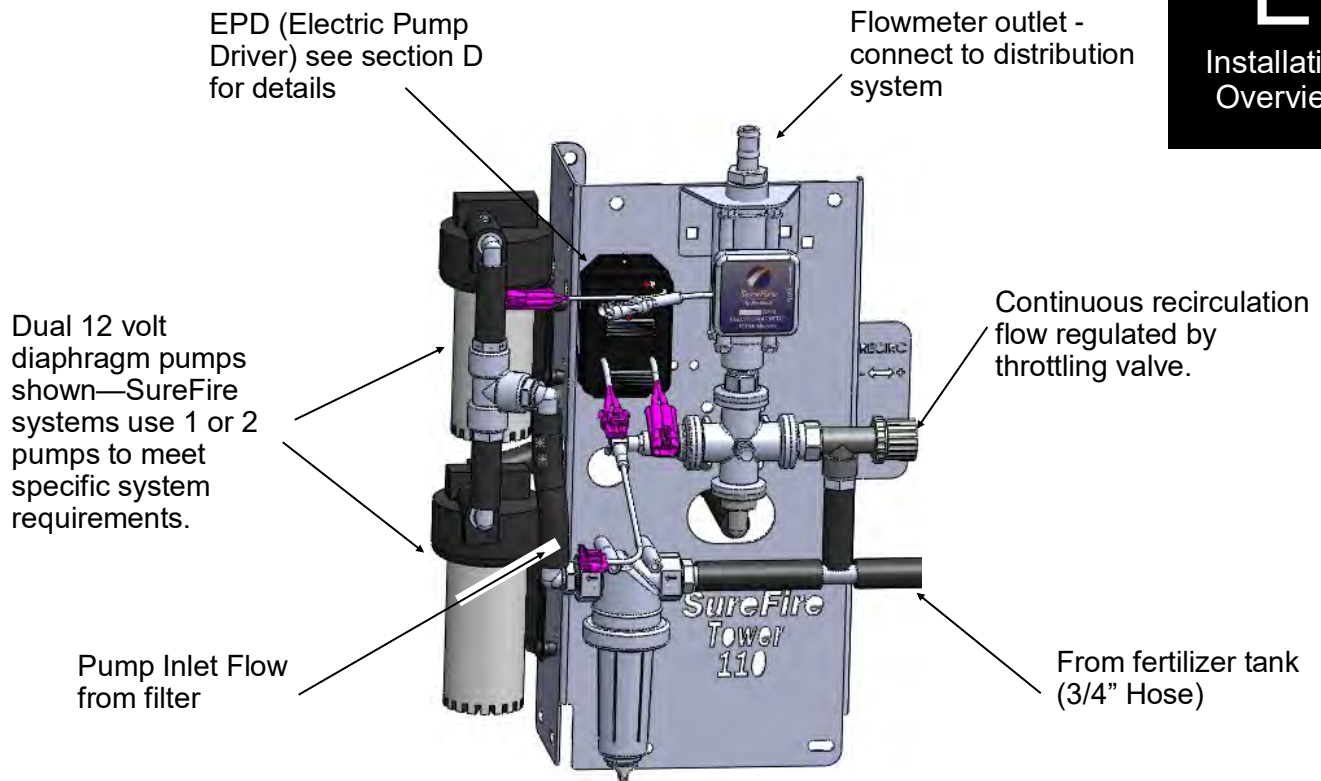

Do I need recirculation flow?

Recirculation flow allows the pump(s) to run faster than if the total pump flow was applied to the ground. This is helpful when operating at very low flow rates. On a Tower 110 equipped with two 5.3 GPM pumps, you likely will NOT open the recirculation valve if applying over 1.5 GPM to the ground.

How to use the Recirculation Adjust Valve:

Follow these steps to set the agitation adjust valve after your system is primed and tested:

1. On the Deere display go to **Tests** and choose **Nozzle Flow Check**. Enter your field operating speed and rate. Turn your master switch on. The system will now operate at your Target Rate and Test Speed.
2. Start with the recirculation adjust valve completely closed and note the slow pump speed (by pump noise).
3. Open the recirculation adjust valve slowly and note the increased pump speed and noise. Start with a half turn of the knob. The system is applying the same amount to the ground, the pumps are now running faster due to more recirculation flow.
4. Set the valve to somewhere in the middle based on visual observation of agitation flow needed. (A quarter to a half turn is often sufficient recirculation to speed the pump up slightly.)
5. On your Deere display, verify the system has locked on to application rate at your agitation valve setting.

Troubleshooting:

- If the system is applying a rate lower than your target, you need to close the agitation adjust valve some.
- If the system is applying a rate higher than you want and will not lock on rate, you need to open the agitation adjust valve some.
- If the rate is still fluctuating around your target and you have a two pump system, unplug one pump. At low flows, one pump may deliver the needed rate and produce a more stable flow.

What if my product needs agitation?

- Tower Electric Pump systems can provide minimal agitation. If more agitation is needed, a separate pump may be needed or the system may need a hydraulic pump. On the Tower 110, simply remove the tee located below the recirculation valve. Connect the main hose from product tank to the filter and connect the tank agitation hose to the recirculation valve. Agitation will reduce the amount the pump can deliver to the rows.

Tower 200 Plumbing Overview

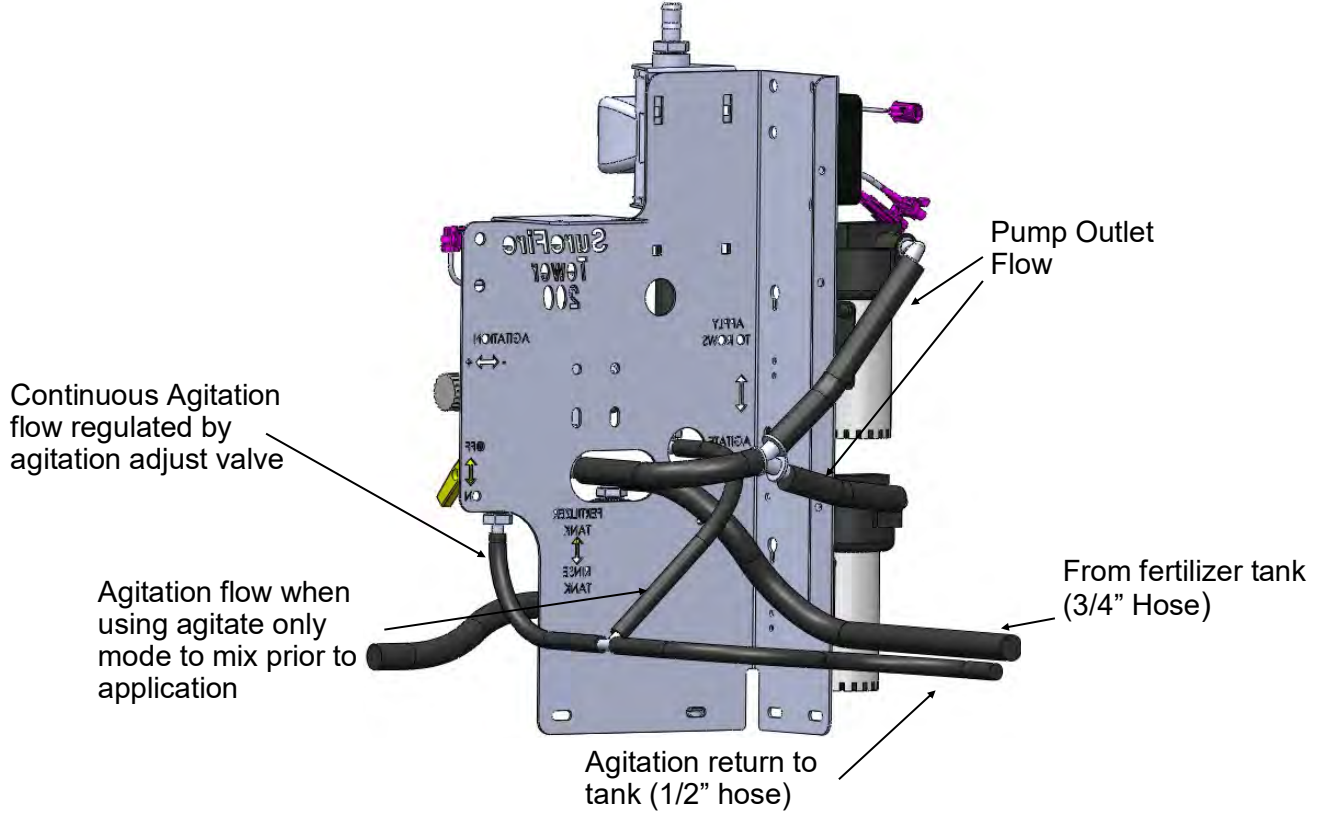
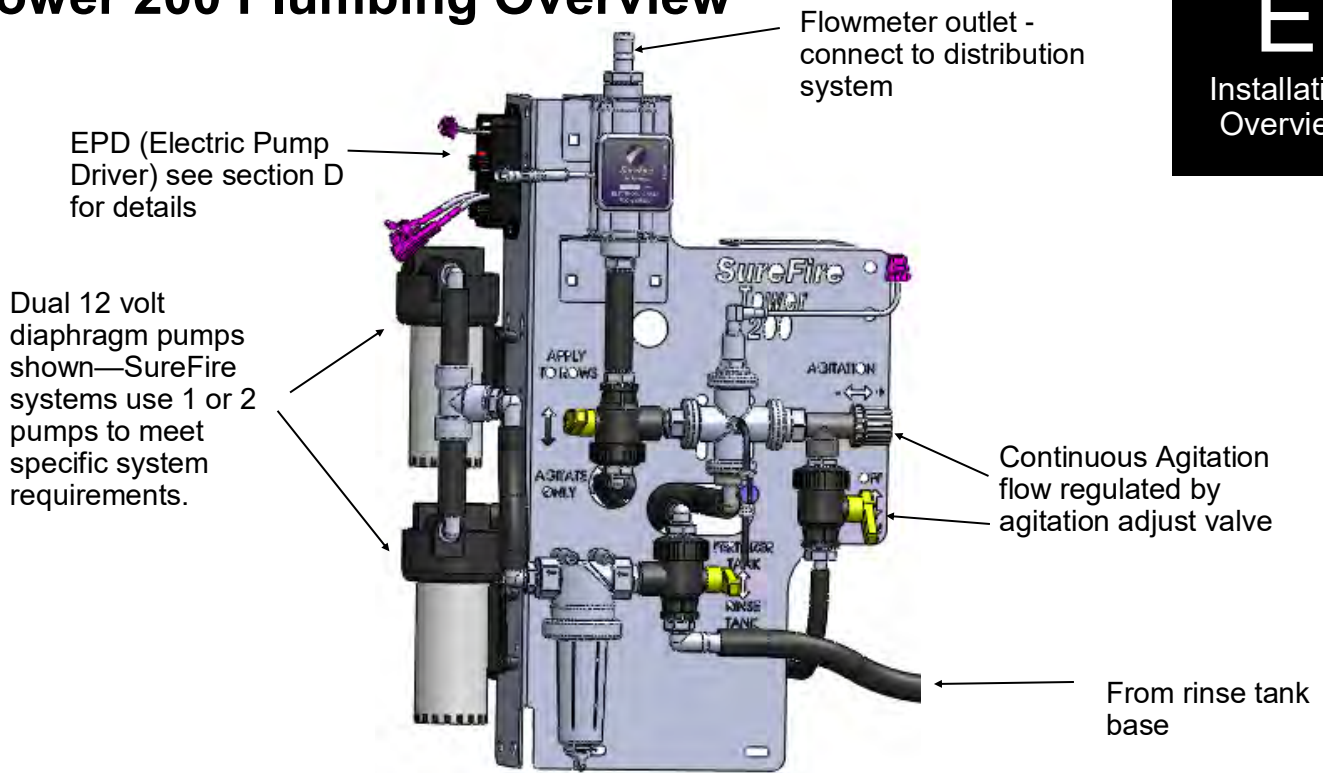

What if my product needs agitation?

- Tower Electric Pump systems can provide minimal agitation. If more agitation is needed, a separate pump may be needed or the system may need a hydraulic pump. Agitation will reduce the amount the pump can deliver to the rows.

Tower 200 Valve Operation

E

Installation
Overview

System Mode Valve: This valve selects if you will apply to the rows. Valve must be in the **up position for field operation**. Move down to Agitate Only for tank mixing prior to field operations.

Tank Selection Valve: This valve selects if product is pulled from the fertilizer tank or rinse tank. **For field operation the valve must be up**. Move down to Rinse Tank to flush fertilizer system.

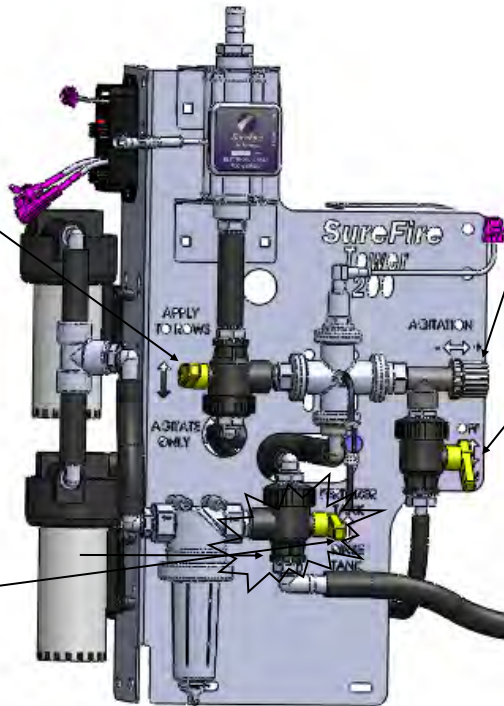

Agitation Adjust Valve: This valve adjusts how much flow returns to the tank while working in the field.

Agitation On/Off Valve: This valve will shut off agitation flow without the need to move the agitation adjust valve. **This valve must be closed when rinsing the system with product still in the fertilizer tank. If not closed, the rinse water will be injected into the fertilizer tank through the agitation line.**

How to use the Agitation Adjust Valve:

Agitation or recirculation flow serves two purposes. First, it mixes products that will separate. Second, it allows the pump(s) to run faster than if the total pump flow was applied to the ground. The pump(s) will become difficult to control if they are operated at the slowest speed possible. By circulating product back to tank, the pump(s) will run faster, producing a more stable flow at low application rates.

Follow these steps to set the agitation adjust valve after your system is primed and tested:

1. On the Deere display go to **Tests** and choose **Nozzle Flow Check**. Enter your field operating speed and rate. Turn your master switch on. The system will now operate at your Target Rate and Test Speed.
2. Open the Agitation On/Off valve.
3. Start with the recirculation adjust valve completely closed and note the slow pump speed (by pump noise).
4. Open the recirculation adjust valve slowly and note the increased pump speed and noise. Start with a half turn of the knob. The system is applying the same amount to the ground; the pumps are now running faster due to more recirculation flow.
5. Set the valve to somewhere in the middle based on visual observation of agitation flow needed. (A quarter to a half turn is often sufficient recirculation to speed the pump up slightly.)
6. On your Deere display, verify the system has locked on to application rate at your agitation valve setting.

Troubleshooting:

- If the system is applying a rate lower than your target, you need to close the agitation adjust valve some.
- If the system is applying a rate higher than you want and will not lock on rate, you need to open the agitation adjust valve some.
- If the rate is still fluctuating around your target and you have a two pump system, unplug one pump. **At low flows, one pump may deliver the needed rate and produce a more stable flow.**

Rate Controller Setup



This manual is written for the John Deere GS2 & GS3 displays with GRC. It is good to update the software on your display and rate controller. Your screens may vary some if using an older or newer version.

To access the GS2/GS3 Rate Controller Functions, push this button. If this button is not present the rate controller is not communicating with the GS2/GS3 display. See your John Deere operators manual or your John Deere dealer for assistance.

This button will take you to the Main Rate Controller Screen below.

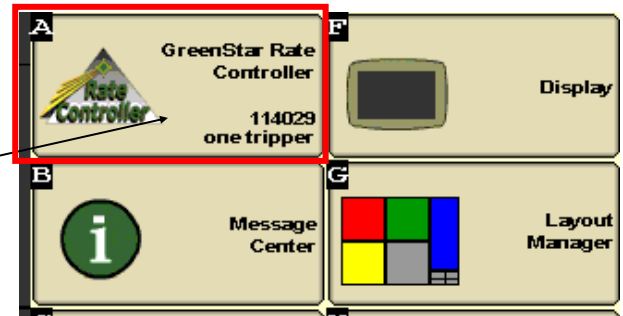

Main Rate Controller Screen

Pressure (if optional pressure sensor installed) OR **Flow in GPM** (without pressure sensor).

Tractor Speed

Navigation Buttons

- Main Rate Controller Screen
- Setup
- Totals
- Diagnostics

Actual Rate: 0.0 gal/ac

Target Rate: 5.0 gal/ac

Implement Height Switch Indicator, Arrow will point up or down to indicate implement position if height switch is used.

Estimated Volume Remaining / Tank Refill Button (press to refill tank): 400 (gal)

Optional Display Items

Rate: Predefined, Rate 1 (5.0), Rate 2 (0.0), Rate 3 (0.0)

0.0 gal/min, 0.0 psi

Menu Structure



Setup

- Implement
- System
- Alarms
- Rates



Totals

- Current
- Job Summaries
- Lifetime Totals



Diagnostics

- Readings
- Tests

Setup - Implement



Here you will enter the **type**, **name**, **total width** and **section width** for the implement you will be using for this operation.

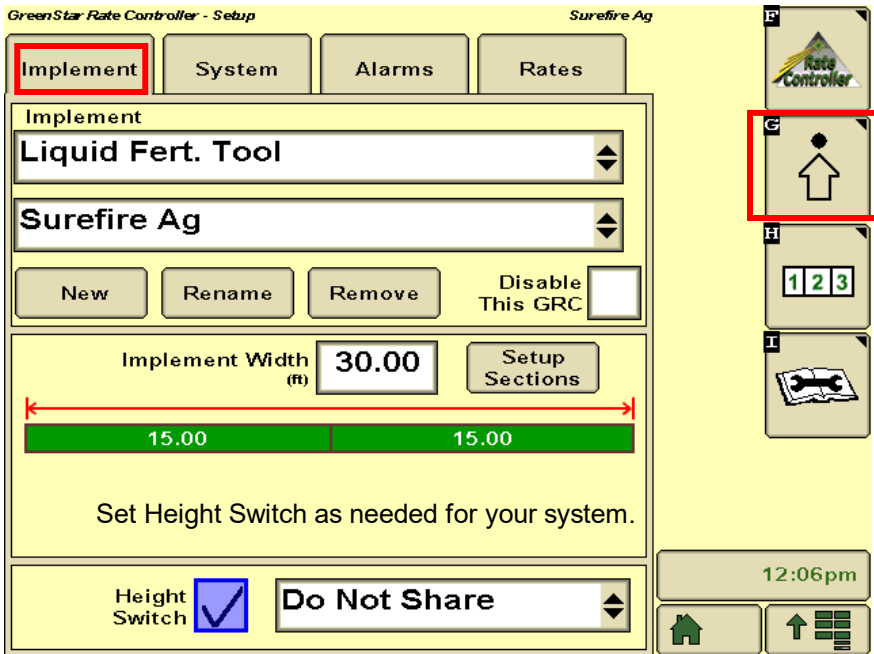

Implement Type, Name & Width

1. Choose **implement type** “Liquid Fert Tool”
2. Enter a **Name** for the Implement where “SureFire Ag” is shown above.
3. Enter your **implement width** in feet.
4. Push **Setup Sections** button if dividing the implement into sections.
5. Setup the **width of each section** on the new screen that pops up.

Height Switch

If using a height switch on your implement, check the box at the bottom of this screen. You must then choose one of the choices at right. On a planter, set this to “Receive Status” to use the Seed Controller’s height signal. (Some Seed Controller/Rate Controller combinations may not allow sharing of the Height Switch.)

On a single product fertilizer applicator you would set to “Do Not Share”.

If you are sharing a height switch, one of the controllers must be set to “Send Status” and the other one set to “Receive Status”.

On previous versions of GS2/GS3 software, a height switch was required for a Liquid Fertilizer Tool. However, on later versions you can leave the Height Switch box unchecked and no height switch is required.

Example only. Your setting may be different.



Setup - System

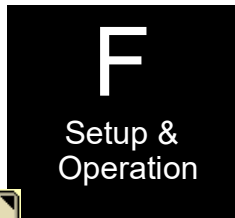

Setup > System is where you will set the John Deere Rate Controller to work with the SureFire fertilizer system components.

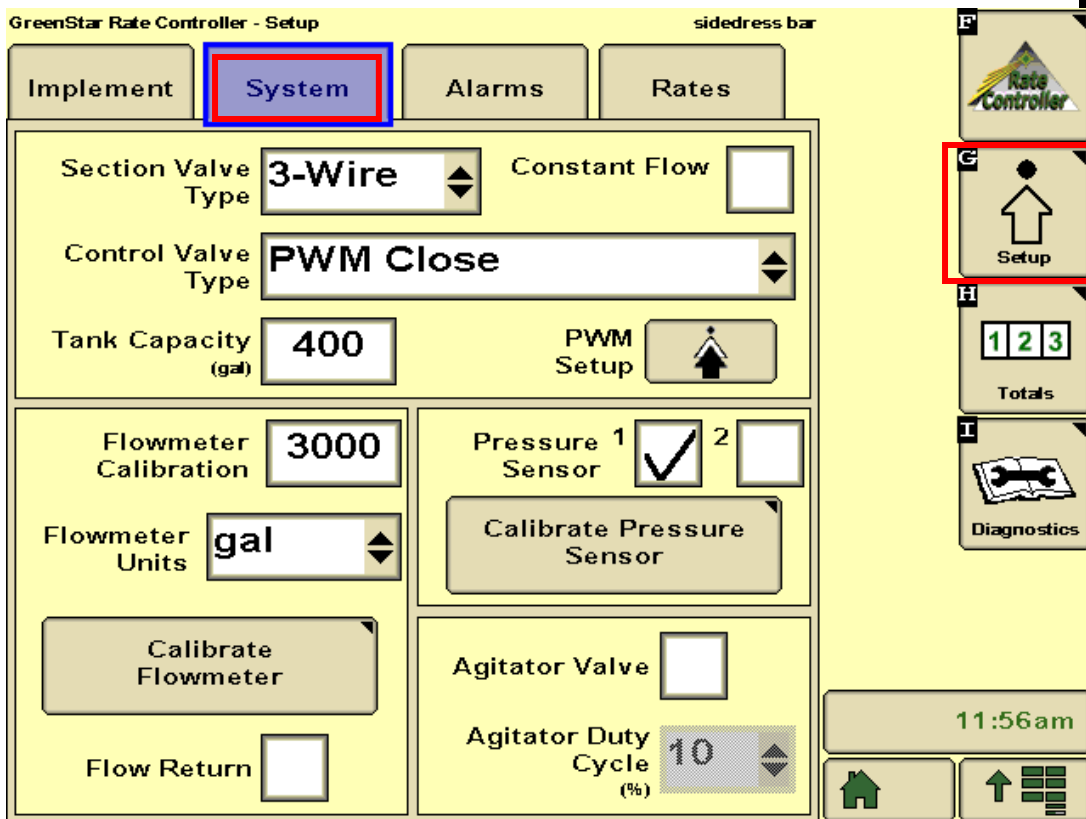

1. **Section Valve Type:** 3-Wire **Constant Flow:** Do NOT check this box.
2. **Control Valve Type:** PWM Close (“Close” means when the rate is zero or all sections are off, the controller will stop the pump)
3. **Flowmeter Calibration:**
 - Electromagnetic Flowmeter: see chart*
4. **Flowmeter Units:** gal
5. **Flow Return:** NOT Checked
6. **Pressure Sensor:** Check #1 and/or #2 if using optional electronic pressure sensor(s). See next page for instructions to calibrate pressure sensor. *(When using the 213-00-3765Y1 adapter harness, the pressure connector on the Section harness is Pressure Sensor 2. On 213-00-3765Y2, Pressure 1 is on the Section 1-6 connector.)*
7. **Agitator Valve:** NOT Checked
8. **Flow Return:** Optional Flow Return connector is on the Section harness, if using this feature.
9. See next page for instructions on “PWM Setup” & “Calibrate Pressure Sensor”

Flowmeter Model (GPM) (orange label or blue label)	GS2 & GS3 Flowmeter Calibration
0.13 - 2.6	3000
0.3 - 5.0	3000
0.08-1.6	22700

*Earlier model flowmeters (meters with white labels with black print) have different calibration numbers. See the documentation with that flowmeter or see the pulses per gallon on the sticker with the Serial Number.

Setup - System (continued)

F

Setup & Operation

PWM Setup

From **System Setup** screen, push “**PWM Setup**” to open this screen.

1. Control Valve Calibration: 9911

The John Deere Rate Controller Control Valve Calibration can be changed to optimize performance on your specific equipment. The 4 digit number is formatted XXYZ. Increase XX to make the system respond quicker. If set too high, the actual rate will oscillate around the target. Y is the output deadband and Z is the control deadband. Generally leave these two digits low. Read your JD Rate Controller Operators Manual for more information. For example, to slow your response speed, move the number from 9911 to 8011, changing the valve response from 99 to 80. SureFire has found the fastest setting has the best performance with electric pump systems.

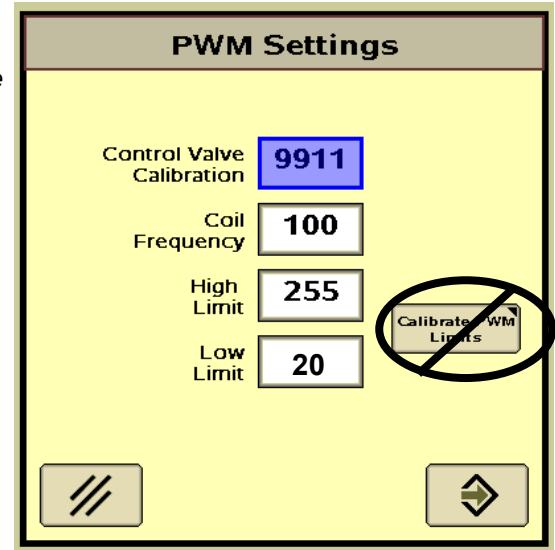

2. **Coil Frequency:** 100
3. **High Limit:** 255 (maximum value allowed)
4. **Low Limit:** 20 (If you are applying a very low rate and pump will not slow down enough, you may have to lower this or else open the Recirculation valve slightly.)

The “Calibrate PWM Limits” button is not necessary after you enter the numbers above.

5. Push the lower right button to return to the System Setup screen.

Tip for faster system startup at beginning of pass:

Increasing the PWM Low Limit may help the system get to Target Rate quicker on startup. If the PWM Low Limit is set too high, the pump will not be able to slow down enough when you slow down or close sections. Go to Diagnostics > Readings > Delivery System to monitor PWM Duty Cycle when running.

Calibrate Pressure Sensor

From System Setup screen, push “**Calibrate Pressure Sensor**” to open this screen.

1. Be sure there is no pressure on the sensor. Unplug the sensor if not sure.
2. Select **Voltage-based Calibration**
2. On the screen that opens up, enter **50.0** mv/psi.
3. Push the lower right button to return to the System Setup screen.
4. Go to Diagnostics > Readings > Sensors/Status. The Calibration Points should show 0 PSI = 0.00 V and 90 PSI = 4.50 V (or very close).

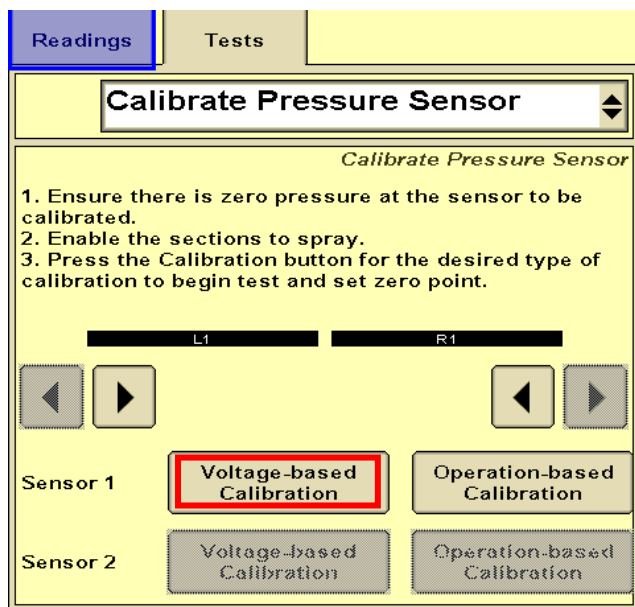

Tip: If the system has been running, there may be pressure in the system due to the check valves. In that case, simply unplug the sensor while this setup is being done so it will calibrate the zero point correctly.

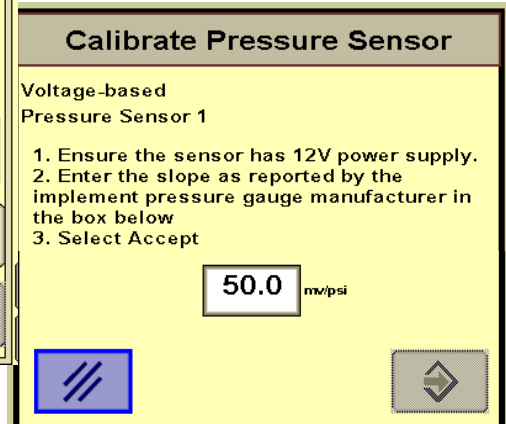

Setup - Alarms



Customize your alarms and settings on this page.

1. **Low Tank Level** can be used by the customer if they desire, but is not required.
2. **High and Low Alarm:** 20% is the John Deere default and SureFire recommended setting. SureFire recommends these alarms be enabled (checkmark in the box).
3. **Minimum Pressure:** 10 psi is a safe minimum pressure to ensure all check valves (4 psi setting) are fully opening and equal flow will go to every row. SureFire recommends turning this alarm off as each time the system turns on & off it will activate, being a nuisance.
4. **Maximum Pressure:** 40 psi is the recommended setting. Electric pumps will draw more current and reduce output flow as pressure increases. **If pressure is routinely over 30 psi, consider changing to a larger orifice or metering tube for optimum performance.** Turn this alarm on so you are warned when system pressure increases for some reason (cold morning operation may trigger this alarm). **Higher pressure is a problem only if it keeps the pump from hitting the Target Rate. The pumps will operate at 50 PSI or more, but pump output will be reduced as pressure increases.**

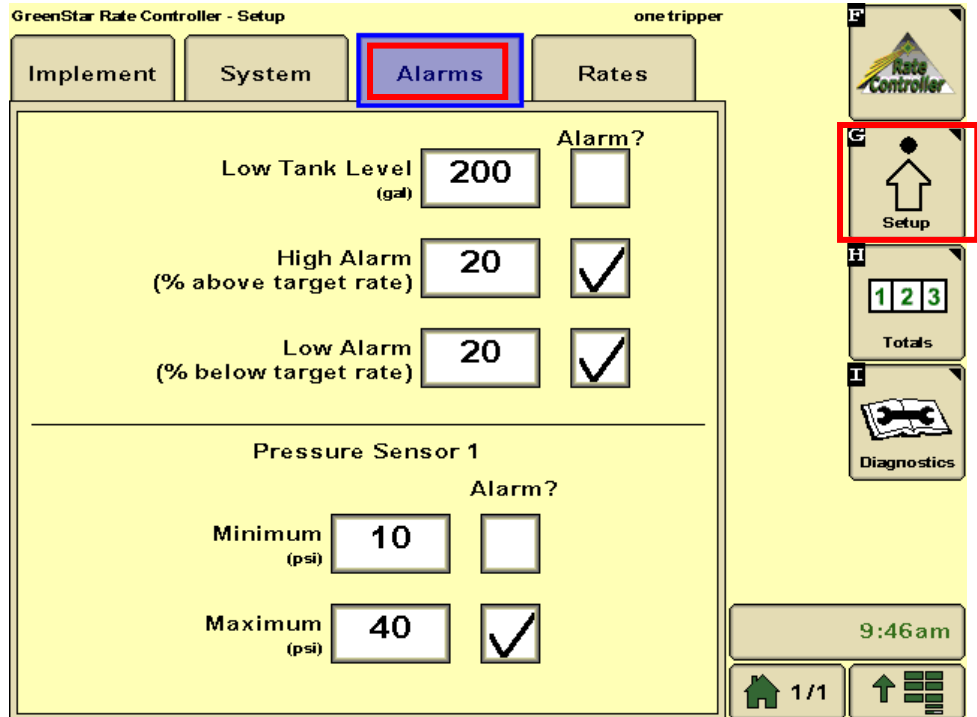

Setup - Rates

Enter your desired application rate(s) here.

1. Enter up to 3 rates.
2. SureFire recommends checking the **Rate Smoothing** box and entering 10%.
3. SureFire recommends leaving **Minimum Flow Rate** at 0.0. If greater than zero, this is the minimum flow in *gallons per minute* that the system will NEVER go lower than. Optionally, it could be set to the minimum flow limit of your flowmeter.

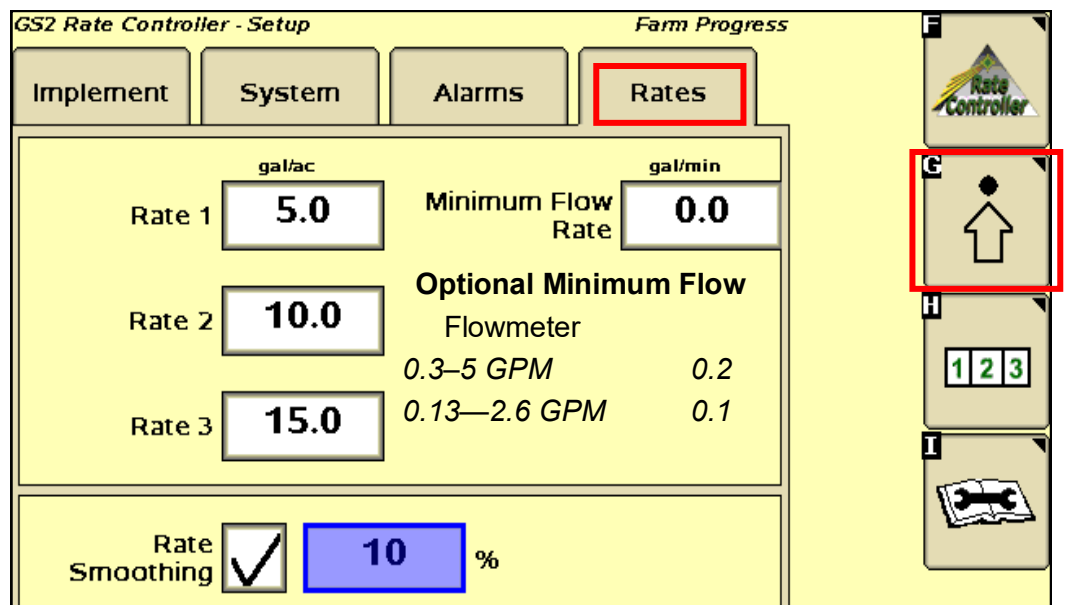

Initial Operation Instructions - Step 1



SureFire highly recommends you perform these exact steps with water to verify system is correctly installed and ready for field use.

1. Go to the **Section Test** or **Calibrate PWM Limits Test** (Diagnostics > Tests > Section Test or Calibrate PWM Limits). These tests function like a MANUAL mode where you have direct control of pump and valves.
2. Turn the Master switch on.
3. Test section valves by checking and unchecking boxes. Check boxes to open all valves.
4. Push the “+” button and **hold it**. Electric pump(s) should begin running. (It takes lots of individual taps of this button to cause a visible effect).
5. Is water being pumped? If system is not primed, open the priming air bleed valve. This will allow air to be expelled and the pump to prime. Be sure the recirculation knob is closed.
6. With pump running and water flowing, push “1,2,3” button. Look at flow in GPM. Is there a reading there? If not, is the system primed with water flowing to every row? If water is flowing, but no reading, check flowmeter calibration and wiring harness connections.
7. Push wrench button, now push the “-” button. Go back to the “1,2,3” screen. Did the flow in GPM decrease?
8. **Make sure the GS2/GS3 flow readout in GPM can be increased and decreased with the plus & minus buttons.**
9. **The system can also be tested using the Calibrate PWM Limits Test. Use the + and - buttons to speed up and slow down the pump.**

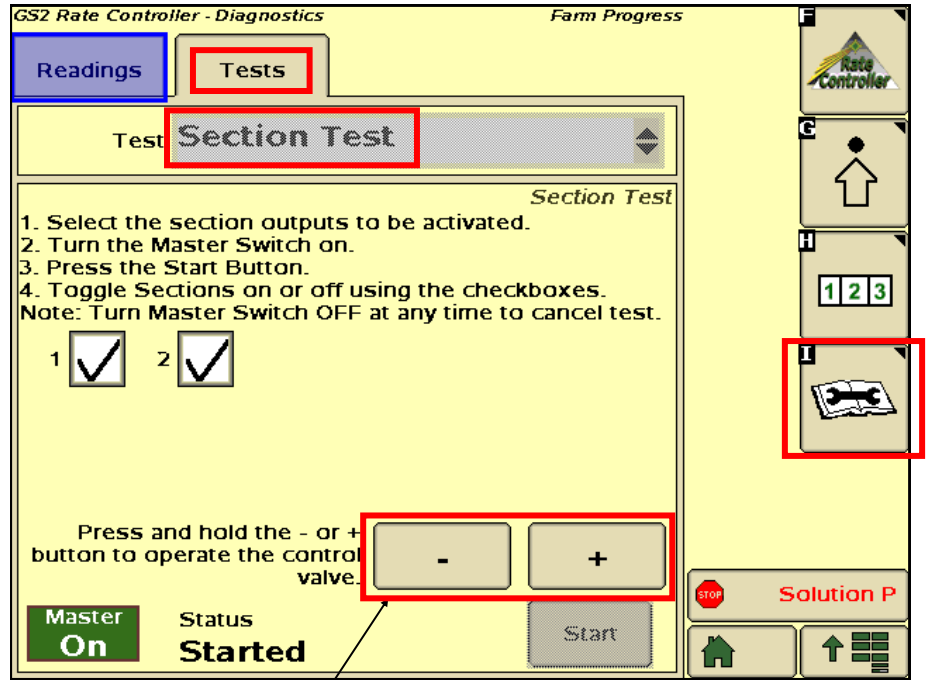

Go to Step 2 on the next page when you can increase and decrease the GPM reading using the + and - buttons.

NOTICE

Running these tests will dispense liquid. Be sure it is safe to dispense the liquid in your tank in this location.

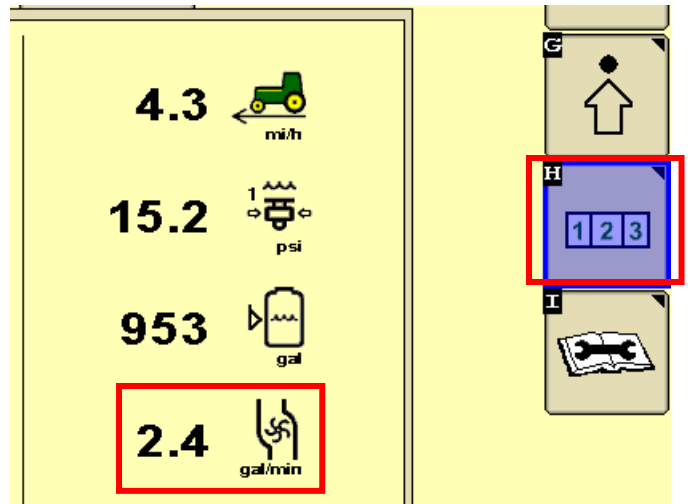

Initial Operation Instructions - Step 2



1. Go to the **Nozzle Flow Check** (Diagnostics > Tests > Nozzle Flow Check). This test will operate the system as if it were running in the field at a speed and application rate you enter.
2. **Test Speed:** Enter your typical field operating speed.
3. **Rate:** Enter your typical application rate.
4. Turn the Master switch on.
5. Pump will turn on and begin applying the entered rate.
6. Observe the system. Are the flow and pressure on the screen stable and reasonable? Is the flow reasonable and equal from each application point?
7. **Repeat this test at minimum and maximum values for both Test Speed and Rate.** Remember heavier fertilizers, such as 10-34-0, will have much higher pressures at a given flow than water.
8. You can use this procedure with fertilizer (instead of water) to verify your minimum pressure is at least 10 psi (to ensure all check valves open). Also check the maximum speed and rate to make sure pressure is under 40 psi (to limit electrical current to pumps). **When testing with water, the pressure will be much less than it will be when using fertilizer. If the pressure is too low, all of the check valves may not open and you may not get flow to every row.**
9. *While the test is running, you can go to **Readings > Delivery System**. Check out the **PWM Duty Cycle**. 255 means the pumps are running full speed. This would not be a good normal operating condition. Be sure the Recirculation knob is closed.*

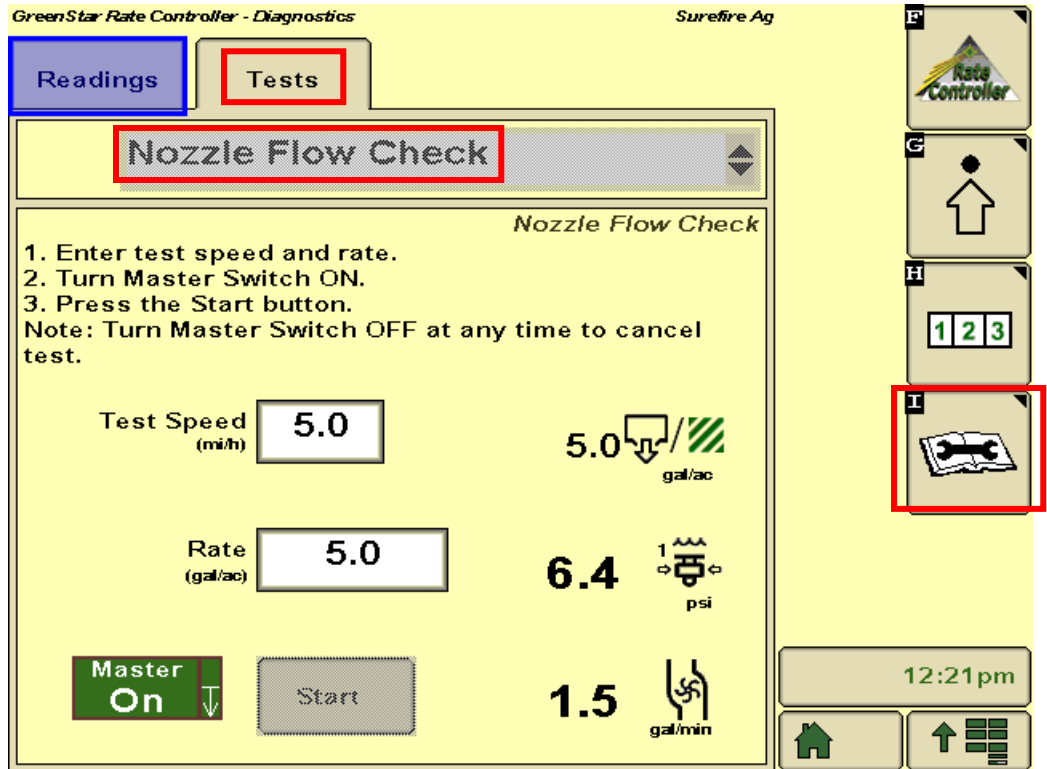

Helpful Tip

*The **Section Test (or Calibrate PWM Limits)** is the first and most basic test to make sure that the system is set up and hooked up correctly. This test verifies that you can run the pump and control the speed of the pump.*

*If there is a problem with the operation of the system, start with the **Section Test or Calibrate PWM Limits Test**.*

NOTICE

Running these tests will dispense liquid. Be sure it is safe to dispense the liquid in your tank in this location.

Initial Operation Instructions - Step 3-Optional



This is a built-in test to calibrate the flowmeter. It also serves as a check that the entire system is setup correctly.

1. Go to **Calibrate Flowmeter - Catch** (Diagnostics > Tests > Calibrate Flowmeter - Catch). The Calibrate Flowmeter screen will pop up.
2. **Number of Nozzles** that will spray: Enter total rows on equipment.
3. **Test Speed**: Enter typical operating speed.
4. **Rate**: Enter typical application rate.
5. **Volume to dispense**: Enter volume that you are capable of catching and measuring from a single nozzle (in ounces).
6. Push continue button in lower right corner. Turn master switch on and begin test.
7. The screen to the right will pop up after test is complete. Enter the sample size collected from 1 row. You need enter only 1 sample measurement. The GS2/GS3 then calculates the new flowmeter calibration value based on the average sample size.

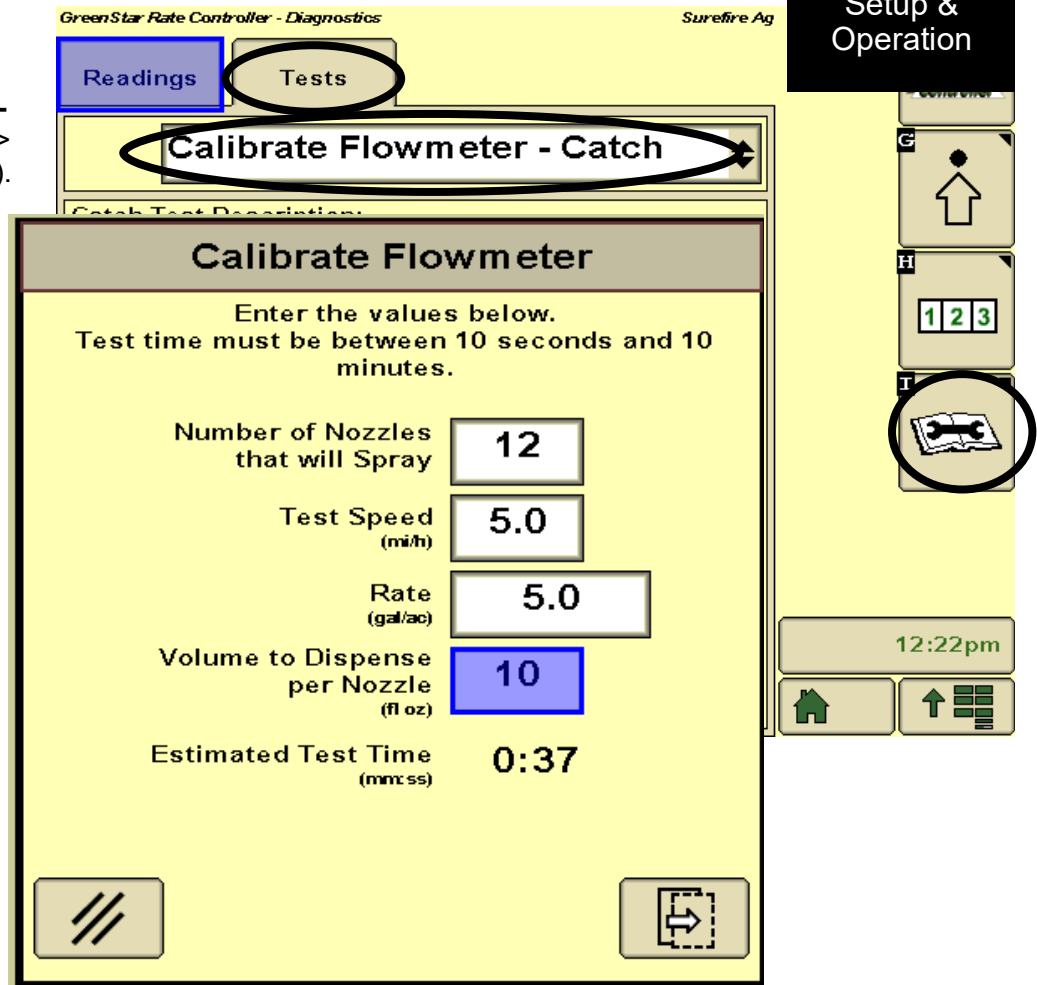

With SureFire Electromagnetic flowmeters, most times the sample volume is correct. In that case, just enter the same sample size you did in #5 above to leave the calibration value unchanged. If the sample volume differs from what is expected, recheck the calibration settings. Do not change the calibration value if there is a small difference in the sample volume. It takes a fairly large sample from several rows to get a number that is accurate enough to change the default Flowmeter Calibration.

SureFire recommends that you do not change the Flowmeter Calibration value unless field use shows that the amount indicated by the flowmeter is not correct.

Pay close attention on the first tanks of fertilizer to verify that the display is measuring correctly.

NOTE: DO NOT ADJUST THE FLOWMETER CALIBRATION VALUE BASED ON A CATCH OF 1 ROW ON AN IMPLEMENT. AT A MINIMUM CATCH 3-4 ROWS.

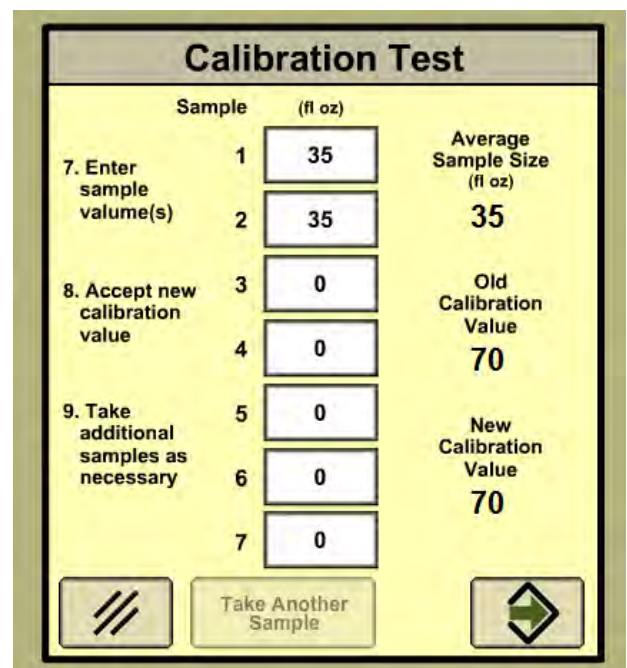

Electric Pumps Won't Run

EPD Status Lights

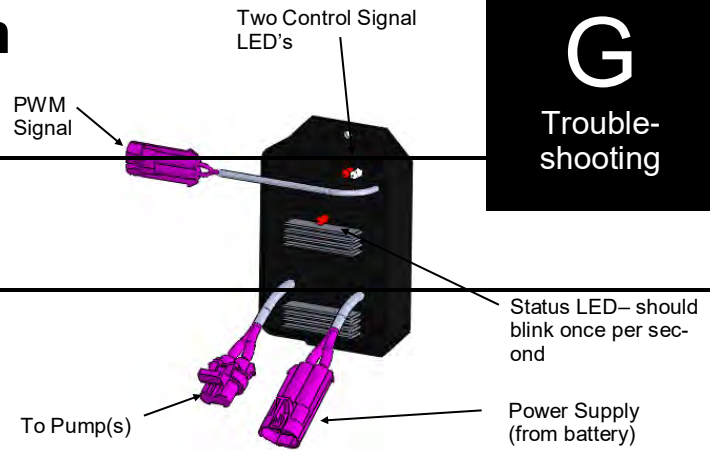

Status LED	Status Description	Troubleshooting Steps
On Steady	Power input is good and PWM input Signal is detected	No Problem, Typical operating condition.
Steady Blink (1 hz— 1 blink/sec)	Power input is good and PWM signal is not detected.	Typical 'Off' Condition. If pumps should be on: 1. Inspect wiring and connectors 2. Check voltage at PWM connector to EPD, should be 1-12 volts to turn on. 3. Check voltage on PWM wires at 37 pin connector, pins 15&16.
Blink once, pause, blink once, pause	Open circuit between motor output and motor.	Check harness and connectors to motor. If using two motors, plug each in separately directly to EPD (bypassing Y-harness)
Blink twice, pause, blink twice, pause	Output short circuit detected.	<ul style="list-style-type: none"> Check motor wiring
Three blinks, pause, three blinks, pause	Overcurrent condition	<ul style="list-style-type: none"> Check total load Clean cooling fins on EPD
Four blinks, pause, four blinks, pause	Input power fault. Low voltage condition in power to EPD.	Unplug battery power from EPD to reset. Check power cables and connections for quality. Be certain that power cable connects directly to battery and has a solid, clean connection. <ul style="list-style-type: none"> Test the voltage under load coming into the EPD. (See picture on page 21 for voltage test point.) Voltage may appear adequate when system is not on, but bad connectors or wiring may not carry the current needed under load.) You may be able to reduce power draw by lowering the system pressure. Typically, though, this is an indication of a cable or connector issue.
Five blinks, pause	Input frequency out of range.	Check PWM Settings on Rate Controller.
Control Signal LEDs (top corner)		
Light intensity varies	Off - No PWM Signal 100% brightness - Maximum PWM input signal	Red light in top corner should be on when PWM signal is received (system is applying product)

The most common issue with the EPD will be a low voltage condition (under load) delivered to the EPD from the battery. Voltage drop occurs anytime current is moved through a wire. A low-voltage (12 v) system with long runs (60-80 feet) may have unacceptable voltage drops if any part of the system is weak or the load is high. This could be bad (corroded, weak, loose or burnt) connectors (at the battery, at the hitch, and at the EPD), too small of wire used (smaller wire equals more voltage drop), low source voltage, and heavy load. Any or all of these may contribute to a low voltage condition under load that may shut down the processor in the EPD module. This will be indicated by 4 quick flashes of the red light, followed by a short pause. Unplug the power-in connector to reset the EPD.

Troubleshooting / Service Guide for SureFire PWM Liquid Application Systems and JD GRC

Always verify the controller settings. See the screenshots in Section F of the system manual and on the QuickStart setup sheet.

G

Troubleshooting

The pump won't run.

Electric Pump System

EPD flashing 4 times

1. Find the EPD module (electric pump driver—black module on Tower). Should have a steady blinking light (one blink per second) in the middle when pumps should be off. In Run mode, the center light should be steady red, the upper right should be steady red (indicates it is receiving a PWM signal). If Status LED (center light) is *flashing 4 times, then pausing*, EPD has tripped due to low voltage condition. Unplug the Power Supply to the EPD to reset. If condition persists, check Power Supply cables from battery to EPD to insure solid connections and good electrical path. Check connections at battery. Check connectors at the hitch and at the EPD. *(There should be 11.5-13 volts at the point where the EPD connects to the battery power harness, when **tested under load**. This voltage may show up when there is no load, but the harnessing may not be good enough to deliver 11.5-13 volts under load.)*

No Lights on EPD

1. There should be a steady blinking light in the middle of the EPD. If no light is ON, check the 40-amp fuse in the EPD harness near the battery. Use a voltmeter to verify that there is 12-13 volts at the Power Supply connector that plugs into the EPD. *If there is good voltage here, but no light on the EPD, replace the EPD module.*

Will pumps run?

1. Connect the two large connectors that are plugged into the bottom of the EPD to each other (bypass the module and supply 12 volts directly to pumps).
2. Do the pumps run? If not, check the 40 amp fuse in the EPD harness near the tractor battery. Inspect harnesses and connections. If 2 pump system, plug pumps in by themselves to check individually. If pump won't run, connect it to pickup battery with jumper cables.

Pumps run, but won't pump anything—

1. Are valves from tank to pump open? Is strainer clean? Close recirculation. Open air bleed valve.
2. Tap on pump with rubber mallet. Pour water (hot, if available) in inlet of pump. Remove outlet hose from pump.

Electric pumps only run with 12 volts direct from battery

Check to see if a PWM signal is getting to the EPD:

1. Connect pumps and power harness back to EPD.
2. Go to **Diagnostics > Tests > Calibrate PWM Limits** to investigate this issue.
3. In Calibrate PWM Limits, hold down "+" button for 8-10 seconds. A single tap of this button produces a very small change in signal to the valve, so you must hold it. *(Look at PWM Duty Cycle –DC%)*
4. Remove PWM valve connector at EPD and check voltage. You will need 6-12 volts to turn pumps on. (PWM Duty Cycle at 100 should be 12+ volts on PWM signal)
5. If 6-12 volts is not present, check harnesses and review control valve type setup (should be PWM Close or PWM).
6. Go back to the 12-pin Deutsch pump connector, check PWM voltage between Pins 5 & 6 (check pins 5 & 2 if wires on PWM connector are Yellow and BLACK).
7. If you have a 37-pin round connector, check the voltage between pins 15 & 16. Also check voltage between pins 2 and 16.

Application Rate & Flow Troubleshooting

G

Troubleshooting

Application Rate Fluctuates

First, you need to determine if the fluctuation is caused by the controller sending fluctuating signals to the valve.

1. **Inspect & clean pump inlet strainer.** Strange flow rate fluctuations are very often due to an obstruction to the pump inlet. Inspect plumbing from tank to pump.

OR

1. Go to **Diagnostics > Tests > Calibrate PWM Limits** as shown in Initial Operation, Section F.
2. Turn the system on and watch the flow in GPM.
3. Is the flow steady within a very small range? For example a fluctuation from 2.3 to 2.5 GPM would be considered normal. A fluctuation from 2-4 GPM is a problem. If only a small normal fluctuation is seen, skip steps 4-8 and proceed to "Application Rate Fluctuates in Field " below.
4. If there is a large fluctuation, observe the system flow. Is the discharge a steady stream? Are the flow indicator balls floating steady?
5. If visually the flow is steady, but the display reports a fluctuation in GPM, inspect the flowmeter. See section B for flowmeter information.
6. If visually the flow is unsteady, the flowmeter is working correctly reporting a flow problem. Is the pump turning steady or surging?
7. Look for any type of obstruction in the pump inlet. Clean the strainer. If continually plugging the strainer, investigate fertilizer quality and necessary strainer size.

Application Rate fluctuates in field, but flow in Section Test mode is stable.

This problem indicates the valve calibration needs changed. The system is surging because the Rate Controller is moving the pump driver or hydraulic valve too much.

1. Go to **Setup - System - PWM Setup**.
2. Change the **Valve Calibration** by reducing the valve speed (first two digits). For example reduce the number for 9911 to 8511, which changes valve speed from 99 to 85.

Application Rate is slow to get to the Target Rate

1. Check the Recirculation knob. If this is open, it will take the pump longer to get the system to Target Rate. Normally, the recirculation should be closed.
2. You may need to increase the **Valve Calibration**. Go to **Setup - System - PWM Setup**.
3. Change the **Valve Calibration** by increasing the valve speed (first two digits). For example, increase the number from 8511 to 9911, which changes valve speed from 85 to 99. (SureFire recommends 9911 for Tower Electric Pump systems, which is the fastest Valve Calibration possible)
4. If system is too slow to get to the Target Rate when starting, go to **Setup > System > PWM Setup**. Raise the **Low Limit**. (If Low Limit is 0, set at 25. This will start the pump at a faster speed when it initially turns on. (This number sets the low limit of your pump, so if it is set too high your pump may not be able to slow down enough at low speed/low rate settings or with some sections turned off.)
5. **Optional Method 1 to get to Target Rate faster:** (Caution: You can only use this method if you have Electric Section Valves.) Go to **Setup - System**. Set **Control Valve Type** to **PWM**. This leaves the pump running at the last speed when product application is stopped. Under **PWM Settings** check the **Pump Enable Checkbox**. With the section valves closed and the pump running, this can build up too much pressure in the system at times. To reduce this pressure, open the Continuous Recirculation Flow Throttling Valve on the Tower slightly (1/4 turn) (see page 30-31). Since this will cause continuous recirculation, it will reduce the maximum output to the rows that is attainable and the pump will run at a higher speed all the time.
6. **Optional Method 2 to get to Target Rate faster:** Use the John Deere Rate Controller **Flow Return** feature. This will involve adding an additional electric valve and plumbing to return flow to the tank when product application is stopped. On the **Setup - System** screen, check the **Flow Return** box. In **Setup - System**, the **Control Valve Type** is set to **PWM**. Under **PWM Settings** check the **Pump Enable Checkbox**. With the Control Valve Type set to **PWM**, the pump continues to run at the last speed it was running when product application was stopped. Flow at this time is returned to the tank. When product application is resumed, flow is diverted from the tank back to the rows.

No Flow shown on display, but liquid is being pumped

Flowmeter Tap Test



See which flowmeter connector you have

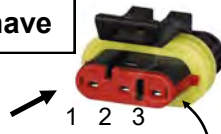

Remove red guard to reach pins. Don't break red side clips.

Flowmeter pinout:

3-pin MP Tower **A- Signal B- 12V Power C- Ground**
3-pin AMP SuperSeal **1- Ground 2- 12V Power 3- Signal**

1. Unplug the flowmeter. With voltmeter, check for **12 volts between Power & Ground** of flowmeter connector. Should have **4-5 volts between signal and ground**. If voltage is not present, inspect wiring harness and check for voltage at harness connection(s) nearer the Rate Controller (at 12-pin Deutsch connector, Power is 1, Ground is 2, Flow Signal is 3).
2. If 12 volts is present, then conduct a **tap test**. Go to **Setup > System** and change the flow cal to 1. Have a second person watch GPM on the 1,2,3 screen while other person taps repeatedly (use a short piece of wire or a paper clip) between signal and ground pins of flowmeter connector. A flow value (gpm) should show up indicating the wiring is not damaged. (If alone, note or reset a volume counter to 0, and start Calibrate PWM Limits Test. Check for increased volume after tapping.)
3. If the flow showed on the display during the tap test, your wiring to that point is good. If tap test did not work, go back to the next harness connection and do a tap test there between signal and ground.
4. If the tap test registers flow on the display, replace flowmeter. (*Sometimes, cleaning the inside tube of the flowmeter with soapy water and a soft brush will remove a film covering the electrodes.*)
5. Change Flow Cal back to appropriate Flow Cal when finished with Tap Test.
6. SureFire has a Speed/Flow Simulator (PN 219-01462) or a Tap Tester (212-03-3912Y1) that can be used to confirm if the wiring is good between the flowmeter and controller.

Field Verification of Flowmeter Calibration

Always verify the flow cal setting by comparing the amount actually applied in the field (from weigh tickets) with the amount shown on the display. Adjust the flow cal as needed to get less than 1% difference between the actual amount applied and the amount shown on the display.

In general:

Increase the Flow Cal number if not enough product is actually being applied. (If you want more, increase the number)

Decrease the Flow Cal number if too much product is being applied. (If you want less, decrease the number)

Formula to Adjust Flow Cal Number

(Volume shown on display) / (Volume actually applied) X flow cal number in display = new flow cal

Example: Display shows 727 gallons was applied. Weigh ticket shows 750 gallons was actually applied. Flow cal number in display was 3000. (*We applied too much, so we will decrease the flow cal.*)

$$727 / 750 \times 3000 = 2908 \text{ (new flow cal number to set in display)}$$

(Any adjustments to the flow cal number will only be as accurate as the measurements used in figuring it.)

Do not power wash the flowmeter.

Unplug the flowmeter before welding on the implement.



Section Valve(s) will not move

1. Go to **Diagnostics > Tests > Section Test** to investigate this issue. If system shuts off with Solution Pump Dry warning, use the Calibrate PWM Limits Test.
2. Start Section Test. Check and uncheck the boxes. With the box checked the valve should turn on. The valve should be off with the box not checked.
3. If none of the valves are working, or if half of the valves are working, it may be a Power (or Ground) issue. The odd-numbered sections have one power source, the even-numbered sections have another power source. (See harness diagrams)

Pin	Function
A	+ 12 V Constant
B	Ground
C	+ 12 V Signal

4. If a valve does not open, switch the connector that is plugged into that valve with a connector that is plugged into a working valve. Also, plug in the connector to the non-working valve to a valve that is working.

5. Check the harness connection to the non-working valve. It is a 3-Pin Weather Pack connector. Check voltage pin A to Pin B. Must be 12 volts, if not, go back to the next harness connection and check the voltage there. (See harness diagrams for pins)

6. If voltage is present on pins A&B of 3 pin connection to valve, then check Pin C to Pin B. This should be 12 volts when the valve is commanded on or open. This should be zero volts when valve is off or closed.
7. If signal voltage is not present to open valve, use diagrams to check at the 14-pin connector, then the 47-pin for voltage on the proper pin for that section.
8. If harnesses and voltages are good, but valve still will not open, remove the actuator from the valve and see if the actuator will work when it is not connected to the valve. Use a wrench to turn the valve to be sure it is moving freely. Be sure actuator and valve are oriented correctly when you put them back together.
9. If constant voltage (Pins A&B) and switched voltage (Pins C&B) are present, inspect, repair or replace the valve.



This is a 3-way valve. If product will not flow when valve is ON, either move the outlet hose to the other outlet port, or remove actuator and rotate valve ball 180°, and replace actuator. Product should flow through the port closest to the Indicator light when the valve is open (green).

Pressure Sensor is not reading

1. Be sure the Pressure Sensor that is displayed on your screen is the same sensor that is plugged into your harness for that product.
2. Make sure the pins where the harness screws on to the end of the sensor have not been bent.
3. Be sure Pressure Sensor is set up and calibrated in the display. Unplug the pressure harness before doing this.

Setup > Settings > Pressure Sensor Setup. Select the sensor you want. > Calibrate Pressure Sensor > Voltage-based Calibration > 50 mv/PSI.

4. There should be a green LED light on the end of the pressure sensor. (may be difficult to see in daylight). The sensor needs 12 v. Check between pins B&C on the Pressure connector on the harness that connects to the pressure sensor. If there is no voltage here, check the voltage between pins 1 & 2 on the 12-pin connector labeled PUMP.
5. **Testing Pressure Sensor Harnessing:** If the pressure sensor is not reading, you can use a AA or AAA battery to test the harnessing. Connect the (-) end of the battery to pin C and the (+) end to pin A of the pressure connector. The 1.5 v should show up as 30 psi on the screen. You can check this at *Diagnostics > Readings > Sensors/Status* (0 PSI should be 0.0v, 90 PSI should be 4.5 v)

Troubleshooting Tip

1. Useful information is available at **Diagnostics > Readings**.
2. Below are examples of some of the screens available:



The screenshots show the following data:

- Delivery System Screen:**
 - Flow Meter (Hz): 0
 - Flow Rate (gal/min): 0.0
 - Spray Rate (gal/ac): 0.0
 - Control Valve (A): 0.010
 - PWM Duty Cycle: 0
- System Voltages Screen:**
 - ECU Power (V): 13.9
 - Valve Power (V): 13.8
 - Sensor Power 1 (V): 5.0
 - Valve Power 1: OK
 - Sensor Power 2 (V): 5.1
 - Valve Power 2: OK
 - Sensor power 3 (V): 5.0
 - Valve Power 3: OK
 - Sensor Power 4 (V): 0.0
 - Valve Power 4: OK
- Sensors/Status Screen:**
 - Pressure Sensor (V): 0.0
 - Calibration Points:
 - 0.0 psi: 0.00 v
 - 90.0 psi: 4.50 v
 - Pressure 1 (psi): 0.0
 - Slope (mv/psi): 50.0

Check the operation of the **flowmeter** here on the Delivery System screen.

NOTICE

The **PWM Duty Cycle** tells how fast the pump is being told to run. The range is from 0 to 255.

Most systems generally should not need to run much more than 150 on the PWM Duty Cycle. If the Duty Cycle is running 200 to 255, there may be other issues. If the system needs to run high Duty Cycles all the time, check to see that the expected pump output is within the pump capacity. Be sure the recirculation knob is closed. Be sure that the system pressure is not too high and limiting the pump output. Be sure that the strainer is not plugged or that there are no other inlet restrictions. Check each pump individually to be sure each is performing adequately.

System Voltages should be similar to those shown here.

Sensors/Status—Check the operation of the **pressure sensor** here. The top number (V) will be between 0 and 5.0.

The **Calibration Points** should indicate that 0.0 psi is 0.00 volts and that 90 PSI is 4.5 volts.

The **Slope** should be 50.0 mv/psi. *If pressure does not show on Pressure 1, try setting up Sensor 2.*

You can test the harnessing for the pressure sensor by using a AA or AAA battery. Connect the (+) end of the battery to pin A of the pressure sensor connector. Connect the (-) end of the battery to pin C. The Pressure Sensor (V) should be approximately 1.5 volts. The Pressure should read about 30 PSI.

Other issues

G

Trouble-
shooting

1. “My rate won’t go low enough. I want 8 gpa, but it won’t go less than 11.”

- A. Check **Setup > Rates > Minimum Flow Rate**. This can be set at 0.0 or at the low range of your flowmeter. This is *gal / min* not *gal / acre*.
- B. Check **Setup > System > PWM Setup > PWM Settings > Low Limit**. Default setting for JD is 15 for electric pumps and 60 for hydraulic pumps. These may be set higher to get the pump to start faster to get to Target Rate sooner, but if set too high, the pump cannot slow down enough when your speed drops or when sections close.
- C. On a hydraulic pump, be sure the red manual override knob is down and locked on the hydraulic valve.

2. “I can’t get up to my rate. I want 12 gpa, and I can’t get more than 10 gpa.”

- A. How many GPM are required to hit your rate? Is this within the pump’s specifications? On an electric pump, the output of the pump decreases as the pressure increases. Keep the pressure under 40 PSI on an electric system. **Is a recirculation valve open**, allowing too much liquid to recirculate?
- B. On a dual electric pump system, check each pump individually to see that each one is working at capacity.
- C. **Is the strainer plugged?** If too small of a mesh strainer is being used, the fluid can gel up around the screen as the fluid is pulled through. Most SureFire systems with metering tube and electromagnetic flowmeter can use a 20- or 30-mesh strainer.
- D. Does the pump have enough hydraulic oil to hit the desired rate? If the pump is in series behind another pump or motor, the hydraulic oil to this pump may be limited. Run pump in Manual Override to see output.
- E. Check **Setup > System > PWM Setup > PWM Settings > High Limit**. This should be 255.
- F. Go to **Diagnostics > Readings > Delivery System**. What is PWM Duty Cycle while the pump is running (in the field or on a Section Test or Nozzle Flow Check)? 255 means the pump is being told to run at full speed.
- G. Run the **Calibrate PWM Limits Test** and hold the (+) button to speed up the pump. Check GPM and PSI at different levels. Check the PWM Duty Cycle at **Diagnostics > Readings > Delivery System**.
- H. Run a Nozzle Flow Check. See gal/ac, PSI, gal/min, and PWM Duty Cycle.
- I. Is the flow cal correct? Is the width of the implement set correctly? Is speed reading correctly?

3. “It’s pretty close to the rate, but it won’t ever lock in to the rate.”

- Go to **Setup > Rates > Rate Smoothing**. Check the box for Rate Smoothing. Put **10** in the box. Without Rate Smoothing it is normal for the system to show the rate constantly changing small amounts as you go across the field. With Rate Smoothing, if the Applied Rate is close to the Target Rate, the display does not show all the small changes.

4. “When I start up, I get a screen that says “Solution Pump Dry”.

This is not unusual on the Deere display. If the flowmeter does not show flow immediately when you start, this screen pops up. It is made to protect centrifugal pumps that can be harmed quickly if they are dry. This is not a problem for SureFire diaphragm pumps. This message may be stopped by going to **Setup > System > PWM Setup > PWM Settings > Low Limit**. **Increase the Low Limit so the pump will start faster.**

Be sure the recirculation knob is closed, so the flow goes to the row and not to recirculation. If you must recirculate, start with a quarter turn of the knob.

5. “What settings do I use for the SureFire system on the original JD Rate Controller?”

The full screenshots of these are in Section F of the manual that came with the system.

Here is a summary of the typical settings: Not everything is shown in this table. Some systems may need to be adjusted for better operation.

Setup Arrow	Tower Electric	PumpRight Hydraulic
Implement	Liq Fert Tool—Set up width, sections, and height switch as needed	
System—Section Valve—Control Valve	3-Wire—PWM Close	
Flowmeter Calibration	3000—gal	2000—gal
PWM Setup	9911—100—255—20	2522—100—255--60
Alarms—Pressure Sensor	10—40	15—80
Rates—Minimum Flow	0.0 or low end of flowmeter (Note: This is Gal/min NOT Gal/acre.)	
Rates—Rate Smoothing	Check the box—10	

6. “My pressure is too high / too low.”

The pressure will be what it is depending on how hard it has to push to get the amount of liquid you are moving from the pressure sensor to where it leaves the system. This pressure will depend on the product itself, the volume (gal/min) you are moving and how much restriction there is to that flow. The orifice or metering tube will be the primary restriction, but it is possible that other parts of the system may add to the total pressure. 1/4" tubing can build a lot of pressure with 10-34-0. The pressure a system develops will be less (possibly much less) with water than it will be with a fertilizer product.

What pressure is “too low”?

You need enough pressure to open the check valves. If the pressure is too low, some check valves will open before others, so that some rows may be flowing while others are not. **With 4 lb check valves, we like at least 8 PSI. With 10 lb check valves, we like 15-20 PSI.**

What pressure is “too high”?

A pressure is too high if it keeps the system from being able to hit the rate you want or if it opens the PRV (Pressure Relief Valve) on a hydraulic pump.

The plumbing components of a SureFire system are rated at 100 PSI or above. On an electric pump system, the pump capacity decreases as the pressure increases. Our standard Tower electric pump has an internal 70 PSI bypass. **With an electric pump, we like to see pressures from 10 to 30 PSI.** If the pump has the capacity to hit the rate at higher pressures, there is not a problem with doing that, but for long-term operation it would be best to switch to a larger orifice or metering tube. High pressure requires more current, which causes more voltage drop, which causes EPD problems.

The SureFire PumpRight hydraulic pump has the ability to pump up to 290 PSI. SureFire plumbs these with a 100 PSI pressure relief valve (PRV) so that plumbing components will not be damaged if high pressure develops. **Typical operating pressures with hydraulic pumps will be 20-60 PSI,** but the pump will work fine at 80-90 PSI if that is needed. If continually running in that high range, consider a larger orifice or metering tube.

Lower pressure will not necessarily reduce the **velocity of the output stream** at the row. Conversely, higher pressure will not necessarily increase the velocity of the output stream at the row. The velocity of the output stream is determined by the volume of the flow and the size of the opening at the output. Changing the pressure by changing an orifice or metering tube upstream from the outlet will not affect the velocity of the output stream if the flow volume remains the same.

Options if pressure is too high with orifices: Use a bigger orifice. Slow down. If pressure is too low, use a smaller orifice.

With metering tube: Options if pressure is too high: Use a larger diameter tube. Shorten the tubes that are on now. Slow down. *(The pressure in a metering tube is related to the viscosity of the product. Many products change viscosity as the temperature changes. A product will have a higher viscosity (and therefore higher pressure) on a cold morning than it will on a hot afternoon.)*

With metering tube: Options if pressure is too low: Switch to a smaller diameter tube. Use a longer tube.

7. How do I set the Recirculation knob? Generally, the recirculation knob is closed. If tank agitation is necessary while applying, the recirculation hose can be plumbed back to the tank. Electric pumps do not have the capacity to do much agitation. A small amount of recirculation may be desired if the pump needs to run slowly and the output is not smooth. Start with a quarter turn of the knob (less on an electric pump). A half turn of the knob will recirculate a lot. If too much is recirculated, the pump may not be able to hit the rate to the rows. Opening recirculation will not lower the pressure required to push the desired product to the rows.

See SureFire publication “[396-3269Y1 Navigating the Metering Tube Maze](#)” or “[396-4116Y1 Metering Tube Charts](#)” for more information on how metering tube works.

See SureFire publication “[396-3229Y1 Liquid System Components Overview](#)” for a description of all the system components and additional troubleshooting/service information.

See the system manual for your system for more complete information. Manuals and publications are available for download at www.surefireag.com.

Also see the John Deere manuals for the GS3 Display and the John Deere Rate Controller for more information on the setup and operation of those components.

Fertilizer System Flow Verification

G

Troubleshooting

I can't get up to my desired rate. How much flow is required?
 Can I achieve a new application rate with my current system?
 How much oil does my PumpRight need?

Follow the steps below:

1. Use the Fertilizer System Flow Charts on the next two pages to find your required flow. First, locate the chart for your implement size. Next, find your operating speed on the left side and your application rate on the top. Record the flow in gallons per minute for your maximum speed and rate and your minimum speed and rate.

A. Maximum Flow _____ GPM (Max Rate & Max Speed)

B. Minimum Flow _____ GPM (Min Rate & Min Speed)

2. Locate your pump model on the chart on this page. Will the pump model provide the maximum flow you need from above?

3. Find your flowmeter model in the chart on this page. Will the flowmeter work at both the maximum and minimum flow your recorded in step 1? If not, a different flowmeter is required.

4. If using section valves you must complete this step.

A. Minimum Flow (from above) ÷ Total Rows = _____ GPM / Row

B. GPM / Row (from line above) x Rows per section = _____ GPM / Section

Will your flowmeter measure the minimum GPM / section?

Tower (Electric Pump) Flow Table

	Max Flow GPM
1-5.3 GPM Pump	3.0
2-5.3 GPM Pumps	5.0
Roller Pump	4.5

PumpRight Flow Table

	Number of Dia-phragms	Max Flow GPM
D70	2	15
D115	3	25
D160	4	35
D250	6	55

Flowmeter Table

Model	Type	Min GPM	Max GPM
FM750LR	Turbine	0.3	12
FM750	Turbine	2	40
FlowMaster 270	Turbine	3.5	70
.13—2.6	Electromagnetic	0.13	2.6
.3—5	Electromagnetic	0.3	5.0
.6—13	Electromagnetic	0.6	13
1.3—26	Electromagnetic	1.3	26
2.6—53	Electromagnetic	2.6	53

Fertilizer System Flow Charts

Use the correct implement width chart to find the required pump flow (in gallons per minute) based on travel speed and application rate

G

Trouble-shooting

Implement Width

15 feet

MPH	Application Rate in Gallons Per Acre												
	2	4	6	8	10	15	20	25	30	35	40	45	50
4	0.2	0.5	0.7	1.0	1.2	1.8	2.4	3.0	3.6	4.2	4.8	5.5	6.1
4.5	0.3	0.5	0.8	1.1	1.4	2.0	2.7	3.4	4.1	4.8	5.5	6.1	6.8
5	0.3	0.6	0.9	1.2	1.5	2.3	3.0	3.8	4.5	5.3	6.1	6.8	7.6
5.5	0.3	0.7	1.0	1.3	1.7	2.5	3.3	4.2	5.0	5.8	6.7	7.5	8.3
6	0.4	0.7	1.1	1.5	1.8	2.7	3.6	4.5	5.5	6.4	7.3	8.2	9.1
6.5	0.4	0.8	1.2	1.6	2.0	3.0	3.9	4.9	5.9	6.9	7.9	8.9	9.8
7	0.4	0.8	1.3	1.7	2.1	3.2	4.2	5.3	6.4	7.4	8.5	9.5	10.6
8	0.5	1.0	1.5	1.9	2.4	3.6	4.8	6.1	7.3	8.5	9.7	10.9	12.1
9	0.5	1.1	1.6	2.2	2.7	4.1	5.5	6.8	8.2	9.5	10.9	12.3	13.6
10	0.6	1.2	1.8	2.4	3.0	4.5	6.1	7.6	9.1	10.6	12.1	13.6	15.2

Implement Width

20 feet

MPH	Application Rate in Gallons Per Acre												
	2	4	6	8	10	15	20	25	30	35	40	45	50
4	0.3	0.6	1.0	1.3	1.6	2.4	3.2	4.0	4.8	5.7	6.5	7.3	8.1
4.5	0.4	0.7	1.1	1.5	1.8	2.7	3.6	4.5	5.5	6.4	7.3	8.2	9.1
5	0.4	0.8	1.2	1.6	2.0	3.0	4.0	5.1	6.1	7.1	8.1	9.1	10.1
5.5	0.4	0.9	1.3	1.8	2.2	3.3	4.4	5.6	6.7	7.8	8.9	10.0	11.1
6	0.5	1.0	1.5	1.9	2.4	3.6	4.8	6.1	7.3	8.5	9.7	10.9	12.1
6.5	0.5	1.1	1.6	2.1	2.6	3.9	5.3	6.6	7.9	9.2	10.5	11.8	13.1
7	0.6	1.1	1.7	2.3	2.8	4.2	5.7	7.1	8.5	9.9	11.3	12.7	14.1
8	0.6	1.3	1.9	2.6	3.2	4.8	6.5	8.1	9.7	11.3	12.9	14.5	16.2
9	0.7	1.5	2.2	2.9	3.6	5.5	7.3	9.1	10.9	12.7	14.5	16.4	18.2
10	0.8	1.6	2.4	3.2	4.0	6.1	8.1	10.1	12.1	14.1	16.2	18.2	20.2

Implement Width

30 feet

MPH	Application Rate in Gallons Per Acre												
	2	4	6	8	10	15	20	25	30	35	40	45	50
4	0.5	1.0	1.5	1.9	2.4	3.6	4.8	6.1	7.3	8.5	9.7	10.9	12.1
4.5	0.5	1.1	1.6	2.2	2.7	4.1	5.5	6.8	8.2	9.5	10.9	12.3	13.6
5	0.6	1.2	1.8	2.4	3.0	4.5	6.1	7.6	9.1	10.6	12.1	13.6	15.2
5.5	0.7	1.3	2.0	2.7	3.3	5.0	6.7	8.3	10.0	11.7	13.3	15.0	16.7
6	0.7	1.5	2.2	2.9	3.6	5.5	7.3	9.1	10.9	12.7	14.5	16.4	18.2
6.5	0.8	1.6	2.4	3.2	3.9	5.9	7.9	9.8	11.8	13.8	15.8	17.7	19.7
7	0.8	1.7	2.5	3.4	4.2	6.4	8.5	10.6	12.7	14.8	17.0	19.1	21.2
8	1.0	1.9	2.9	3.9	4.8	7.3	9.7	12.1	14.5	17.0	19.4	21.8	24.2
9	1.1	2.2	3.3	4.4	5.5	8.2	10.9	13.6	16.4	19.1	21.8	24.5	27.3
10	1.2	2.4	3.6	4.8	6.1	9.1	12.1	15.2	18.2	21.2	24.2	27.3	30.3

Fertilizer System Flow Charts

G

Trouble-shooting

Use the correct implement width chart to find the required pump flow (in gallons per minute) based on travel speed and application rate

Implement Width **40 feet**

MPH	Application Rate in Gallons Per Acre												
	2	4	6	8	10	15	20	25	30	35	40	45	50
4	0.6	1.3	1.9	2.6	3.2	4.8	6.5	8.1	9.7	11.3	12.9	14.5	16.2
4.5	0.7	1.5	2.2	2.9	3.6	5.5	7.3	9.1	10.9	12.7	14.5	16.4	18.2
5	0.8	1.6	2.4	3.2	4.0	6.1	8.1	10.1	12.1	14.1	16.2	18.2	20.2
5.5	0.9	1.8	2.7	3.6	4.4	6.7	8.9	11.1	13.3	15.6	17.8	20.0	22.2
6	1.0	1.9	2.9	3.9	4.8	7.3	9.7	12.1	14.5	17.0	19.4	21.8	24.2
6.5	1.1	2.1	3.2	4.2	5.3	7.9	10.5	13.1	15.8	18.4	21.0	23.6	26.3
7	1.1	2.3	3.4	4.5	5.7	8.5	11.3	14.1	17.0	19.8	22.6	25.5	28.3
8	1.3	2.6	3.9	5.2	6.5	9.7	12.9	16.2	19.4	22.6	25.9	29.1	32.3
9	1.5	2.9	4.4	5.8	7.3	10.9	14.5	18.2	21.8	25.5	29.1	32.7	36.4
10	1.6	3.2	4.8	6.5	8.1	12.1	16.2	20.2	24.2	28.3	32.3	36.4	40.4

Implement Width **60 feet**

MPH	Application Rate in Gallons Per Acre												
	2	4	6	8	10	15	20	25	30	35	40	45	50
4	1.0	1.9	2.9	3.9	4.8	7.3	9.7	12.1	14.5	17.0	19.4	21.8	24.2
4.5	1.1	2.2	3.3	4.4	5.5	8.2	10.9	13.6	16.4	19.1	21.8	24.5	27.3
5	1.2	2.4	3.6	4.8	6.1	9.1	12.1	15.2	18.2	21.2	24.2	27.3	30.3
5.5	1.3	2.7	4.0	5.3	6.7	10.0	13.3	16.7	20.0	23.3	26.7	30.0	33.3
6	1.5	2.9	4.4	5.8	7.3	10.9	14.5	18.2	21.8	25.5	29.1	32.7	36.4
6.5	1.6	3.2	4.7	6.3	7.9	11.8	15.8	19.7	23.6	27.6	31.5	35.5	39.4
7	1.7	3.4	5.1	6.8	8.5	12.7	17.0	21.2	25.5	29.7	33.9	38.2	42.4
8	1.9	3.9	5.8	7.8	9.7	14.5	19.4	24.2	29.1	33.9	38.8	43.6	48.5
9	2.2	4.4	6.5	8.7	10.9	16.4	21.8	27.3	32.7	38.2	43.6	49.1	54.5
10	2.4	4.8	7.3	9.7	12.1	18.2	24.2	30.3	36.4	42.4	48.5	54.5	60.6

Implement Width **90 feet**

MPH	Application Rate in Gallons Per Acre												
	2	4	6	8	10	15	20	25	30	35	40	45	50
4	1.5	2.9	4.4	5.8	7.3	10.9	14.5	18.2	21.8	25.5	29.1	32.7	36.4
4.5	1.6	3.3	4.9	6.5	8.2	12.3	16.4	20.5	24.5	28.6	32.7	36.8	40.9
5	1.8	3.6	5.5	7.3	9.1	13.6	18.2	22.7	27.3	31.8	36.4	40.9	45.5
5.5	2.0	4.0	6.0	8.0	10.0	15.0	20.0	25.0	30.0	35.0	40.0	45.0	50.0
6	2.2	4.4	6.5	8.7	10.9	16.4	21.8	27.3	32.7	38.2	43.6	49.1	54.5
6.5	2.4	4.7	7.1	9.5	11.8	17.7	23.6	29.5	35.5	41.4	47.3	53.2	59.1
7	2.5	5.1	7.6	10.2	12.7	19.1	25.5	31.8	38.2	44.5	50.9	57.3	63.6
8	2.9	5.8	8.7	11.6	14.5	21.8	29.1	36.4	43.6	50.9	58.2	65.5	72.7
9	3.3	6.5	9.8	13.1	16.4	24.5	32.7	40.9	49.1	57.3	65.5	73.6	81.8
10	3.6	7.3	10.9	14.5	18.2	27.3	36.4	45.5	54.5	63.6	72.7	81.8	90.9

Recommended Care and Maintenance

H

Maintenance
& Parts

Winterization

SureFire recommends flushing your fertilizer pump and complete system with adequate amounts of water first. Next, use RV antifreeze to winterize your system by pumping an adequate amount through all components. At the beginning of the next season, begin with water to verify the system is in working order with no leaks.

Clean all harness connections.

Inspect Electric Pumps

The electric pump and motor is a completely sealed component. Over time the electric motor will lose efficiency. The entire pump and motor will need replaced when it won't efficiently produce the flow required.

Each individual pump should be able to produce 4 gpm of water flow with an open outlet (zero pressure). If pump falls short of this specification, replace to ensure a trouble-free fertilizing operation.

You can test the operation of each pump individually by unplugging one pump and running one pump at a time. Compare the output of each pump to each other and to the standard above. If pump runs, but does not pump, tap on pump with rubber mallet. Pour water (hot, if available) into the pump inlet.

Pre-season Service

(A little time spent here may prevent some downtime when you want to be rolling.)

1. Visually check entire system (hoses, fittings, harnesses, etc.) for any signs of wear or trouble. Particularly check all 37- and 16-pin connectors on systems that have been in use. Be sure pins are clean, not corroded, and are making good contact.
2. On the display, recheck all setup screens (see Section F) to verify correct setup.
3. Fill system with water and run in Manual mode (Section Test or Calibrate PWM Limits) to verify components and system are in working order. (May need to open air bleed valve to prime pump the first time. Be sure recirculation knob is closed.)
4. Unplug one pump at a time to verify that each pump is operating as it should. Check GPM output of each pump.
5. Tighten all clamps. Loose clamps may be evident by leaks on the output side of the system. Loose clamps from the tank to the pump are not always apparent, but can be sources of air getting into the system which can create issues.
6. Push in all QuickConnect (QC) fittings to be sure the tubes are tightly seated. QC fittings that are not sealed can cause check valves to leak.
7. Remove the black cap from the top of each check valve. Check the diaphragm to be sure it is intact and not gummed up with residue. Look under the diaphragm for debris. Compress the spring in the cap to be sure it moves freely. Carefully replace diaphragm and tighten cap.
8. Remove and clean the strainer. Be sure strainer is tightened securely so it will not suck air.
9. Be sure all rows are flowing and that all metering tubes/orifices are open. (Note: It will take a higher flow rate with water to create enough pressure to open all the check valves so that each row will flow.)
10. Run system with a Nozzle Flow Check with speed and rate to be used in the field.

SureFire Ag Systems

9904 Hwy 25

Atwood, KS 67730

www.surefireag.com

©2010-2019 SureFire Ag Systems

